

PHILIPPINE BIDDING DOCUMENTS

(As Harmonized with Development Partners)

REBIDDING OF DESIGN AND BUILD OF VARIOUS CIVIL WORKS FOR CRCF ITB NO. 2023-08-12

Department of Social Welfare and
Development Field Office 10
Government of the Republic of the Philippines

Sixth Edition

August 4, 2023

TABLE OF CONTENTS

Glossary of Terms, Abbreviations, and Acronyms	3
Section I. Invitation to Bid	6
Section II. Instructions to Bidders	10
1. Error! Bookmark not defined.....11	11
2. Error! Bookmark not defined.11	
3. Error! Bookmark not defined.11	
4. Error! Bookmark not defined.11	
5. Error! Bookmark not defined.11	
6. Error! Bookmark not defined.12	
7. Error! Bookmark not defined.12	
8. Error! Bookmark not defined.12	
9. Error! Bookmark not defined.12	
10. Error! Bookmark not defined.12	
11. Error! Bookmark not defined.13	
12. Error! Bookmark not defined.13	
13. Error! Bookmark not defined.13	
14. Error! Bookmark not defined.14	
15. Error! Bookmark not defined.14	
16. Error! Bookmark not defined.14	
17. Error! Bookmark not defined.14	
18. Error! Bookmark not defined.14	
19. Error! Bookmark not defined.15	
20. Error! Bookmark not defined.15	
21. Error! Bookmark not defined.15	
Section III. Bid Data Sheet	16
Section IV. General Conditions of Contract	20
1. 21	
2. 21	
3. 21	
4. 21	

5.	22	
6.	22	
7.	2222	
8.	2222	
9.	222	
10.	222	
11.	2323	
12.	2323	
13.	2323	
14.	2323	
15.	2323	
Section V. Special Conditions of Contract		25
Section VI. Specifications		28
Section VII. Drawings		237
Section VIII. Bill of Quantities		249
Section IX. Checklist of Technical and Financial Documents		250
Section X. Bidding Forms		253

Glossary of Terms, Abbreviations, and Acronyms

ABC – Approved Budget for the Contract.

ARCC – Allowable Range of Contract Cost.

BAC – Bids and Awards Committee.

Bid – A signed offer or proposal to undertake a contract submitted by a bidder in response to and in consonance with the requirements of the bidding documents. Also referred to as *Proposal* and *Tender*. (2016 revised IRR, Section 5[c])

Bidder – Refers to a contractor, manufacturer, supplier, distributor and/or consultant who submits a bid in response to the requirements of the Bidding Documents. (2016 revised IRR, Section 5[d])

Bidding Documents – The documents issued by the Procuring Entity as the bases for bids, furnishing all information necessary for a prospective bidder to prepare a bid for the Goods, Infrastructure Projects, and/or Consulting Services required by the Procuring Entity. (2016 revised IRR, Section 5[e])

BIR – Bureau of Internal Revenue.

BSP – Bangko Sentral ng Pilipinas.

CDA – Cooperative Development Authority.

Consulting Services – Refer to services for Infrastructure Projects and other types of projects or activities of the GOP requiring adequate external technical and professional expertise that are beyond the capability and/or capacity of the GOP to undertake such as, but not limited to: (i) advisory and review services; (ii) pre-investment or feasibility studies; (iii) design; (iv) construction supervision; (v) management and related services; and (vi) other technical services or special studies. (2016 revised IRR, Section 5[i])

Contract – Refers to the agreement entered into between the Procuring Entity and the Supplier or Manufacturer or Distributor or Service Provider for procurement of Goods and Services; Contractor for Procurement of Infrastructure Projects; or Consultant or Consulting Firm for Procurement of Consulting Services; as the case may be, as recorded in the Contract Form signed by the parties, including all attachments and appendices thereto and all documents incorporated by reference therein.

Contractor – is a natural or juridical entity whose proposal was accepted by the Procuring Entity and to whom the Contract to execute the Work was awarded. Contractor as used in these Bidding Documents may likewise refer to a supplier, distributor, manufacturer, or consultant.

CPI – Consumer Price Index.

DOLE – Department of Labor and Employment.

DTI – Department of Trade and Industry.

Foreign-funded Procurement or Foreign-Assisted Project – Refers to procurement whose funding source is from a foreign government, foreign or international financing institution as specified in the Treaty or International or Executive Agreement. (2016 revised IRR, Section 5[b]).

GFI – Government Financial Institution.

GOCC – Government-owned and/or –controlled corporation.

Goods – Refer to all items, supplies, materials and general support services, except Consulting Services and Infrastructure Projects, which may be needed in the transaction of public businesses or in the pursuit of any government undertaking, project or activity, whether in the nature of equipment, furniture, stationery, materials for construction, or personal property of any kind, including non-personal or contractual services such as the repair and maintenance of equipment and furniture, as well as trucking, hauling, janitorial, security, and related or analogous services, as well as procurement of materials and supplies provided by the Procuring Entity for such services. The term “related” or “analogous services” shall include, but is not limited to, lease or purchase of office space, media advertisements, health maintenance services, and other services essential to the operation of the Procuring Entity. (2016 revised IRR, Section 5[r])

GOP – Government of the Philippines.

Infrastructure Projects – Include the construction, improvement, rehabilitation, demolition, repair, restoration or maintenance of roads and bridges, railways, airports, seaports, communication facilities, civil works components of information technology projects, irrigation, flood control and drainage, water supply, sanitation, sewerage and solid waste management systems, shore protection, energy/power and electrification facilities, national buildings, school buildings, hospital buildings, and other related construction projects of the government. Also referred to as *civil works or works*. (2016 revised IRR, Section 5[u])

LGUs – Local Government Units.

NFCC – Net Financial Contracting Capacity.

NGA – National Government Agency.

PCAB – Philippine Contractors Accreditation Board.

PhilGEPS - Philippine Government Electronic Procurement System.

Procurement Project – refers to a specific or identified procurement covering goods, infrastructure project or consulting services. A Procurement Project shall be described, detailed, and scheduled in the Project Procurement Management Plan prepared by the agency which shall be consolidated in the procuring entity's Annual Procurement Plan. (GPPB Circular No. 06-2019 dated 17 July 2019)

PSA – Philippine Statistics Authority.

SEC – Securities and Exchange Commission.

SLCC – Single Largest Completed Contract.

UN – United Nations.

DSWD-FOX

Section I. Invitation to Bid

DSWD-FOX

INVITATION TO BID FOR THE Rebidding of Design and Build of Various Civil Works for CRCF

1. The *Department of Social Welfare and Development Field Office 10*, through the **Current Appropriations GAA 2023** intends to apply the sum of **Forty Five Million Five Hundred Nineteen Thousand Pesos (Php 45,519,000.00)** being the Approved Budget for the Contract (ABC) to payments under the contract for the Rebidding of Design and Build of Various Civil Works for CRCF under ITB NO.2023-08-12. Bids received in excess of the ABC shall be automatically rejected at bid opening.

Lot 1 – Construction of Ecumenical Chapel (Design and Build)	1,000,000.00
Lot 2 - Major Repair of the Homelife Building Roof (Design and Build)	5,664,300.00
Lot 3 - Rehabilitation of Bahay Silungan Building and Installation of Fire Alarm & Detection System with Sprinklers (Design and Build)	6,225,320.64
Lot 4 - Construction of Storage Warehouse for Bahay Silungan (Design and Build)	5,400,000.00
Lot 5 - Construction of Pumphouse with Equipment (Design and Build)	8,230,385.11
Lot 6 - Construction of Powerhouse with Equipment (Design and Build)	11,198,994.25
Lot 7 - Construction of Storage Area for RHFV (Design and Build)	3,500,000.00
Lot 8 - Construction of Roadway and Parking Area (Design and Build)	4,300,000.00
TOTAL	Php 45,519,000.00

2. The Department of Social Welfare and Development Field Office 10 now invites bids for the above Procurement Project. Completion of the Works is required should be based on what is stipulated in the Schedule of Requirements. Prospective Bidders must have completed a similar contract within the preceding two (2) years, a single contract equivalent to at least fifty (50%) percent of the Approved Budget Cost per Lot to be bid. The description of an eligible bidder is contained in the Bidding Documents, particularly, in Section II. Instructions to Bidders.

3. Bidding will be conducted through open competitive bidding procedures using a non-discretionary “pass/fail” criterion as specified in the 2016 Revised Implementing Rules and Regulations (IRR) of Republic Act (RA) 9184, otherwise known as the “Government Procurement Reform Act”.
4. Prospective bidders may obtain further information from DSWD FO 10 and inspect the Bidding Documents at the address given below during weekdays (except holidays) from **8:00 AM - 5:00 PM starting August 7, 2023.**
5. A complete set of Bidding Documents may be acquired by interested bidders on the given address and website(s) below and upon payment of the applicable fee for the Bidding Documents, pursuant to the latest Guidelines issued by the GPPB. The procuring entity shall allow the bidder to present its proof of payment for the fees in person or through e-mail during the conduct of bid opening.

	ABC (in Php)	COST (in Php)
Lot 1	1,000,000.00	1,000.00
Lot 2	5,664,300.00	10,000.00
Lot 3	6,225,320.64	10,000.00
Lot 4	5,400,000.00	10,000.00
Lot 5	8,230,385.11	10,000.00
Lot 6	11,198,994.25	25,000.00
Lot 7	3,500,000.00	5,000.00
Lot 8	4,300,000.00	5,000.00

6. The *DSWD FO 10* will hold a Virtual Pre-Bid Conference through videoconferencing via google meet (<https://meet.google.com/qum-izzx-rnm>) on **August 14, 2023 @ 1:30 PM onwards**, which shall be open to prospective bidders.
7. Bids must be duly received by the BAC Secretariat through manual submission at the address below on or before **August 28, 2023 @ 1:30 PM.** Late bids shall not be accepted.
8. All Bids must be accompanied by a bid security in any of the acceptable forms and in the amount stated in ITB Clause 15.
9. Virtual Bid opening through videoconferencing via Google meet shall be on **August 28, 2023 @ 1:30 PM onwards.** Bids will be opened in the presence of the bidders’ representatives who choose to attend the activity. The links will be provided upon submission of bid documents.
10. Each Bidder shall submit one (1) original and two (2) more duplicate copies which should be labeled as “Copy 1” and “Copy 2”. To resolve cases where there is an occurrence of a tie among bidders, i.e., two or more of the bidders have been post-qualified as the Lowest Calculated Responsive Bid (LCRB), the DSWD FO X shall resort to a non-discretionary

and non-discriminatory measure such that the same is based on sheer luck or chance as per GPPB Circular No. 06-2005 "Tie-Breaking Method".

11. The *DSWD FO 10* reserves the right to reject any and all bids, declare a failure of bidding, or not award the contract at any time prior to contract award in accordance with Section 41 of RA 9184 and its IRR, without thereby incurring any liability to the affected bidder or bidders.

12. For further information, please refer to:

ATTY. JUSTINE PHILLIP O. TADEO

Head, BAC Secretariat

DSWD Field Office No.10

Masterson Avenue, Upper Carmen, Cagayan de Oro City

Tel No. (088) 858-6333 local 102

Mobile No. +639067979674

bac.fo10@dswd.gov.ph

13. You may visit the following websites for downloading of Invitation to Bid:
www.philgeps.gov.ph or **<https://fo10.dswd.gov.ph/>**

August 4, 2023

RONALD RYAN R. CUI
BAC Chairperson

Section II. Instructions to Bidders

DSWD-FOX

1. Scope of Bid

The Procuring Entity, Department of Social Welfare and Development Field Office 10 invites Bids for the Rebidding of Design and Build of Various Civil Works for CRCF, with Project Identification Number 2023-08-12.

The Procurement Project (referred to herein as “Project”) is for the construction of Works, as described in Section VI (Specifications).

2. Funding Information

2.1. The GOP through the source of funding as indicated below for **Current Appropriations GAA 2023** in the amount of **Forty Five Million Five Hundred Nineteen Thousand Pesos (Php 45,519,000.00)**.

2.2. The source of funding is the General Appropriations Act.

3. Funding Information

The Bidding for the Project shall be governed by all the provisions of RA No. 9184 and its 2016 revised IRR, including its Generic Procurement Manual and associated policies, rules and regulations as the primary source thereof, while the herein clauses shall serve as the secondary source thereof.

Any amendments made to the IRR and other GPPB issuances shall be applicable only to the ongoing posting, advertisement, or invitation to bid by the BAC through the issuance of a supplemental or bid bulletin.

The Bidder, by the act of submitting its Bid, shall be deemed to have inspected the site, determined the general characteristics of the contracted Works and the conditions for this Project, such as the location and the nature of the work; (b) climatic conditions; (c) transportation facilities; (c) nature and condition of the terrain, geological conditions at the site communication facilities, requirements, location and availability of construction aggregates and other materials, labor, water, electric power and access roads; and (d) other factors that may affect the cost, duration and execution or implementation of the contract, project, or work and examine all instructions, forms, terms, and project requirements in the Bidding Documents.

4. Corrupt, Fraudulent, Collusive, Coercive, and Obstructive Practices

The Procuring Entity, as well as the Bidders and Contractors, shall observe the highest standard of ethics during the procurement and execution of the contract. They or through an agent shall not engage in corrupt, fraudulent, collusive, coercive, and obstructive practices defined under Annex “I” of the 2016 revised IRR of RA No. 9184 or other integrity violations in competing for the Project.

5. Eligible Bidders

- 5.1. Only Bids of Bidders found to be legally, technically, and financially capable will be evaluated.
- 5.2. The Bidder must have an experience of having completed a Single Largest Completed Contract (SLCC) that is similar to this Project, equivalent to at least fifty percent (50%) of the ABC adjusted, if necessary, by the Bidder to current prices using the PSA's CPI, except under conditions provided for in Section 23.4.2.4 of the 2016 revised IRR of RA No. 9184.

A contract is considered to be "similar" to the contract to be bid if it has the major categories of work stated in the BDS.
- 5.3. For Foreign-funded Procurement, the Procuring Entity and the foreign government/foreign or international financing institution may agree on another track record requirement, as specified in the Bidding Document prepared for this purpose.
- 5.4. The Bidders shall comply with the eligibility criteria under Section 23.4.2 of the 2016 IRR of RA No. 9184.

6. Origin of Associated Goods

There is no restriction on the origin of Goods other than those prohibited by a decision of the UN Security Council taken under Chapter VII of the Charter of the UN.

7. Subcontracts

7.1 The Bidder may subcontract portions of the Project to the extent allowed by the Procuring Entity as stated herein, but in no case more than fifty percent (50%) of the Project.

The Procuring Entity has prescribed that Subcontracting is not allowed.

8. Pre-Bid Conference

The Procuring Entity will hold a pre-bid conference for this Project through videoconferencing via google meet (<https://meet.google.com/qum-izzx-rnm>) on August 14, 2023 @ 1:30 PM onwards.

9. Clarification and Amendment of Bidding Documents

Prospective bidders may request for clarification on and/or interpretation of any part of the Bidding Documents. Such requests must be in writing and received by the Procuring Entity, either at its given address or through electronic mail indicated in the IB, at least ten (10) calendar days before the deadline set for the submission and receipt of Bids.

10. Documents Comprising the Bid: Eligibility and Technical Components

10.1 The first envelope shall contain the eligibility and technical documents of the Bid as specified in Section IX. Checklist of Technical and Financial Documents.

10.2. If the eligibility requirements or statements, the bids, and all other documents for submission to the BAC are in foreign language other than English, it must be accompanied by a translation in English, which shall be authenticated by the appropriate Philippine foreign service establishment, post, or the equivalent office having jurisdiction over the foreign bidder's affairs in the Philippines. For Contracting Parties to the Apostille Convention, only the translated documents shall be authenticated through an apostille pursuant to GPPB Resolution No. 13-2019 dated 23 May 2019. The English translation shall govern, for purposes of interpretation of the bid.

10.3. A valid PCAB License is required, and in case of joint ventures, a valid special PCAB License, and registration for the type and cost of the contract for this Project. Any additional type of Contractor license or permit shall be indicated in the BDS.

10.4. A List of Contractor's key personnel (e.g., Project Manager, Project Engineers, Materials Engineers, and Foremen) assigned to the contract to be bid, with their complete qualification and experience data shall be provided. These key personnel must meet the required minimum years of experience set in the BDS.

10.5. A List of Contractor's major equipment units, which are owned, leased, and/or under purchase agreements, supported by proof of ownership, certification of availability of equipment from the equipment lessor/vendor for the duration of the project, as the case may be, must meet the minimum requirements for the contract set in the BDS.

11. Documents Comprising the Bid: Financial Component

11.1. The second bid envelope shall contain the financial documents for the Bid as specified in Section IX. Checklist of Technical and Financial Documents.

11.2. Any bid exceeding the ABC indicated in paragraph 1 of the IB shall not be accepted.

11.3. For Foreign-funded procurement, a ceiling may be applied to bid prices provided the conditions are met under Section 31.2 of the 2016 revised IRR of RA No. 9184.

12. Alternative Bids

Bidders shall submit offers that comply with the requirements of the Bidding Documents, including the basic technical design as indicated in the drawings and specifications. Unless there is a value engineering clause in the BDS, alternative Bids shall not be accepted.

13. Bid Prices

All bid prices for the given scope of work in the Project as awarded shall be considered as fixed prices, and therefore not subject to price escalation during contract implementation, except under extraordinary circumstances as determined by the NEDA and approved by the GPPB pursuant to the revised Guidelines for Contract Price Escalation guidelines.

14. Bid and Payment Currencies

14.1. Bid prices may be quoted in the local currency or tradeable currency accepted by the BSP at the discretion of the Bidder. However, for purposes of bid evaluation, Bids denominated in foreign currencies shall be converted to Philippine currency based on the exchange rate as published in the BSP reference rate bulletin on the day of the bid opening.

14.2. Payment of the contract price shall be made in Philippine Pesos.

15. Bid Security

15.1. The Bidder shall submit a Bid Securing Declaration or any form of Bid Security in the amount indicated in the BDS, which shall be not less than the percentage of the ABC in accordance with the schedule in the BDS.

15.2. The Bid and bid security shall be valid until **December 26, 2023**. Any bid not accompanied by an acceptable bid security shall be rejected by the Procuring Entity as non-responsive.

16. Sealing and Marking of Bids

Each Bidder shall submit one copy of the first and second components of its Bid.

The Procuring Entity may request additional hard copies and/or electronic copies of the Bid. However, failure of the Bidders to comply with the said request shall not be a ground for disqualification.

If the Procuring Entity allows the submission of bids through online submission to the given website or any other electronic means, the Bidder shall submit an electronic copy of its Bid, which must be digitally signed. An electronic copy that cannot be opened or is corrupted shall be considered non-responsive and, thus, automatically disqualified.

17. Deadline for Submission of Bids

The Bidders shall submit on the specified date and time and either at its physical address or through online submission as indicated in paragraph 7 of the IB.

18. Opening and Preliminary Examination of Bids

18.1. The BAC shall open the Bids in public at the time, on the date, and at the place specified in paragraph 9 of the IB. The Bidders' representatives who are present shall sign a register evidencing their attendance. In case videoconferencing, webcasting or other similar technologies will be used, attendance of participants shall likewise be recorded by the BAC Secretariat.

In case the Bids cannot be opened as scheduled due to justifiable reasons, the rescheduling requirements under Section 29 of the 2016 revised IRR of RA No. 9184 shall prevail.

18.2. The preliminary examination of Bids shall be governed by Section 30 of the 2016 revised IRR of RA No. 9184.

19. Detailed Evaluation and Comparison of Bids

19.1. The Procuring Entity's BAC shall immediately conduct a detailed evaluation of all Bids rated "passed" using non-discretionary pass/fail criteria. The BAC shall consider the conditions in the evaluation of Bids under Section 32.2 of 2016 revised IRR of RA No. 9184.

19.2. If the Project allows partial bids, all Bids and combinations of Bids as indicated in the BDS shall be received by the same deadline and opened and evaluated simultaneously so as to determine the Bid or combination of Bids offering the lowest calculated cost to the Procuring Entity. Bid Security as required by ITB Clause 16 shall be submitted for each contract (lot) separately.

19.3. In all cases, the NFCC computation pursuant to Section 23.4.2.6 of the 2016 revised IRR of RA No. 9184 must be sufficient for the total of the ABCs for all the lots participated in by the prospective Bidder.

20. Post Qualification

Within a non-extendible period of five (5) calendar days from receipt by the Bidder of the notice from the BAC that it submitted the Lowest Calculated Bid, the Bidder shall submit its latest income and business tax returns filed and paid through the BIR Electronic Filing and Payment System (eFPS), and other appropriate licenses and permits required by law and stated in the BDS.

21. Signing of the Contract

The documents required in Section 37.2 of the 2016 revised IRR of RA No. 9184 shall form part of the Contract. Additional Contract documents are indicated in the BDS.

Section III. Bid Data Sheet

DSWD-FOX

Bid Data Sheet

ITB Clause							
5.2	<p>For this purpose, contracts similar to the Project refer to contracts which have the same major categories of work, which shall be:</p> <p>The Bidder must have completed, within the period specified in the Invitation to Bid, a single contract that is similar to this Project, equivalent to at least fifty percent (50%) of the ABC.</p>						
7.1	No portion of the contract shall be subcontracted.						
10.4	<p>The key personnel must meet the required minimum years of experience set below:</p> <p>Design Phase Key Personnel</p> <ul style="list-style-type: none"> ● Principal Architect, Certified practicing Professional with minimum experience of five (5) years; ● Structural Design Engineer with minimum experience of five (5) years; ● Professional Electrical Engineer with minimum experience of five (5) years; ● Senior Sanitary/Environmental Engineer with minimum experience of five (3) years; ● Mechanical Engineer with minimum experience of five (5) years; <p>Construction Phase Key Personnel</p> <ul style="list-style-type: none"> ● Project Manager with 5 years minimum experience ● Project Engineer with 5 years minimum experience ● Professional Architect with 5 years minimum experience ● Materials Engineer, (DPWH Accredited) with 3 years minimum experience ● Professional Mechanical Engineer with 5 years minimum experience ● Professional Electrical Engineer with 5 years minimum experience ● DOLE Accredited Safety Officer with 5 years minimum experience ● Sanitary Engineer/Master Plumber, 3 years minimum experience ● Experienced Construction Foreman, 5 years minimum experience ● CAD Operator/Draftsman with 2 years minimum experience 						
10.5	<p>The minimum major equipment requirements are the following:</p> <table style="width: 100%; border-collapse: collapse;"> <thead> <tr> <th style="text-align: left;"><u>Equipment</u></th> <th style="text-align: left;"><u>Capacity</u></th> <th style="text-align: left;"><u>Number of Units</u></th> </tr> </thead> <tbody> <tr> <td> </td> <td> </td> <td> </td> </tr> </tbody> </table>	<u>Equipment</u>	<u>Capacity</u>	<u>Number of Units</u>			
<u>Equipment</u>	<u>Capacity</u>	<u>Number of Units</u>					
12	No further instructions.						
15.1	<p>The bid security shall be in the form of a Bid Securing Declaration or any of the following forms and amounts:</p> <p>a. The amount of not less than _____ [Insert two percent (2%) of ABC], if bid security is in cash, cashier's/manager's check, bank draft/guarantee or irrevocable letter of credit;</p>						

b. The amount of not less than _____ [Insert five percent (5%) of ABC] if bid security is in Surety Bond.

Amount as follows:

	ABC	2%	5%
LOT 1	1,000,000.00	20,000.00	50,000.00
LOT 2	5,664,300.00	113,286.00	283,215.00
LOT 3	6,225,320.64	124,506.41	311,266.03
LOT 4	5,400,000.00	108,000.00	270,000.00
LOT 5	8,230,385.11	164,607.70	411,519.26
LOT 6	11,198,994.25	223,979.89	559,949.71
LOT 7	3,500,000.00	70,000.00	175,000.00
LOT 8	4,300,000.00	86,000.00	215,000.00

Partial bids are allowed. All Goods are grouped in lots/line items listed below. Bidders shall have the option of submitting a proposal on any or all lots/line items and evaluation and contract award will be undertaken on a per lot/ line item basis. Lots shall not be divided further into sub-lots for the purpose of bidding, evaluation, and contract award.

In all cases, the NFCC computation, if applicable, must be sufficient for all the lots or contracts to be awarded to the Bidder.

	ABC
LOT 1	1,000,000.00
LOT 2	5,664,300.00
LOT 3	6,225,320.64
LOT 4	5,400,000.00
LOT 5	8,230,385.11
LOT 6	11,198,994.25
LOT 7	3,500,000.00
LOT 8	4,300,000.00

19.2

20

Failure to submit the Latest Income and Business Tax Returns and Certificate of PhilGEPS Registration within the non-extendible period of three (3) days shall result to disqualification and forfeiture of bid security.

21

List of additional contract documents relevant to the Project as required by existing laws and/or the Procuring Entity:

- i. Construction schedule and S-curve
- ii. Manpower Schedule
- iii. Construction Methods
- iv. Equipment Utilization Schedule
- v. Construction Safety and Health Program approved by the Department of Labor and Employment
- vi. PERT/CPM, and
- vii. Contractor's All Risk Insurance.

DSWD-FOX

Section IV. General Conditions of Contract

DSWD-FOX

1. Scope of Contract

This Contract shall include all such items, although not specifically mentioned, that can be reasonably inferred as being required for its completion as if such items were expressly mentioned herein. All the provisions of RA No. 9184 and its 2016 revised IRR, including the Generic Procurement Manual, and associated issuances, constitute the primary source for the terms and conditions of the Contract, and thus, applicable in contract implementation. Herein clauses shall serve as the secondary source for the terms and conditions of the Contract.

This is without prejudice to Sections 74.1 and 74.2 of the 2016 revised IRR of RA No. 9184 allowing the GPPB to amend the IRR, which shall be applied to all procurement activities, the advertisement, posting, or invitation of which were issued after the effectivity of the said amendment.

2. Sectional Completion of Works

If sectional completion is specified in the **Special Conditions of Contract (SCC)**, references in the Conditions of Contract to the Works, the Completion Date, and the Intended Completion Date shall apply to any Section of the Works (other than references to the Completion Date and Intended Completion Date for the whole of the Works).

3. Possession of Site

3.1 The Procuring Entity shall give possession of all or parts of the Site to the Contractor based on the schedule of delivery indicated in the **SCC**, which corresponds to the execution of the Works. If the Contractor suffers delay or incurs cost from failure on the part of the Procuring Entity to give possession in accordance with the terms of this clause, the Procuring Entity's Representative shall give the Contractor a Contract Time Extension and certify such sum as fair to cover the cost incurred, which sum shall be paid by Procuring Entity.

3.2 If possession of a portion is not given by the above date, the Procuring Entity will be deemed to have delayed the start of the relevant activities. The resulting adjustments in contract time to address such delay may be addressed through contract extension provided under Annex "E" of the 2016 revised IRR of RA No. 9184.

4. The Contractor's Obligations

The Contractor shall employ the key personnel named in the Schedule of Key Personnel indicating their designation, in accordance with **ITB** Clause 10.3 and specified in the **BDS**, to carry out the supervision of the Works.

The Procuring Entity will approve any proposed replacement of key personnel only if their relevant qualifications and abilities are equal to or better than those of the personnel listed in the Schedule.

5. Performance Security

- 5.1. Within ten (10) calendar days from receipt of the Notice of Award from the Procuring Entity but in no case later than the signing of the contract by both parties, the successful Bidder shall furnish the performance security in any of the forms prescribed in Section 39 of the 2016 revised IRR.
- 5.2. The Contractor, by entering into the Contract with the Procuring Entity, acknowledges the right of the Procuring Entity to institute action pursuant to RA No. 3688 against any subcontractor be they an individual, firm, partnership, corporation, or association supplying the Contractor with labor, materials and/or equipment for the performance of this Contract.

6. Site Investigation Reports

The Contractor, in preparing the Bid, shall rely on any Site Investigation Reports referred to in the SCC supplemented by any information obtained by the Contractor.

7. Warranty

- 7.1. In case the Contractor fails to undertake the repair works under Section 62.2.2 of the 2016 revised IRR, the Procuring Entity shall forfeit its performance security, subject its property (ies) to attachment or garnishment proceedings, and perpetually disqualify it from participating in any public bidding. All payables of the GOP in his favor shall be offset to recover the costs.
- 7.2. The warranty against Structural Defects/Failures, except that occasioned-on force majeure, shall cover the period from the date of issuance of the Certificate of Final Acceptance by the Procuring Entity. Specific duration of the warranty is found in the SCC.

8. Liability of the Contractor

Subject to additional provisions, if any, set forth in the SCC, the Contractor's liability under this Contract shall be as provided by the laws of the Republic of the Philippines.

If the Contractor is a joint venture, all partners to the joint venture shall be jointly and severally liable to the Procuring Entity.

9. Termination for Other Causes

Contract termination shall be initiated in case it is determined *prima facie* by the Procuring Entity that the Contractor has engaged, before, or during the implementation of the contract, in unlawful deeds and behaviors relative to contract acquisition and implementation, such as, but not limited to corrupt, fraudulent, collusive, coercive, and obstructive practices as stated in ITB Clause 4.

10. Dayworks

Subject to the guidelines on Variation Order in Annex “E” of the 2016 revised IRR of RA No. 9184, and if applicable as indicated in the **SCC**, the Day works rates in the Contractor’s Bid shall be used for small additional amounts of work only when the Procuring Entity’s Representative has given written instructions in advance for additional work to be paid for in that way.

11. Program of Work

11.1. The Contractor shall submit to the Procuring Entity’s Representative for approval the said Program of Work showing the general methods, arrangements, order, and timing for all the activities in the Works. The submissions of the Program of Work are indicated in the **SCC**.

11.2. The Contractor shall submit to the Procuring Entity’s Representative for approval an updated Program of Work at intervals no longer than the period stated in the **SCC**. If the Contractor does not submit an updated Program of Work within this period, the Procuring Entity’s Representative may withhold the amount stated in the **SCC** from the next payment certificate and continue to withhold this amount until the next payment after the date on which the overdue Program of Work has been submitted.

12. Instructions, Inspections and Audits

The Contractor shall permit the GOP or the Procuring Entity to inspect the Contractor’s accounts and records relating to the performance of the Contractor and to have them audited by auditors of the GOP or the Procuring Entity, as may be required.

13. Advance Payment

The Procuring Entity shall, upon a written request of the Contractor which shall be submitted as a Contract document, make an advance payment to the Contractor in an amount not exceeding fifteen percent (15%) of the total contract price, to be made in lump sum, or at the most two installments according to a schedule specified in the **SCC**, subject to the requirements in Annex “E” of the 2016 revised IRR of RA No. 9184.

14. Progress Payments

The Contractor may submit a request for payment for Work accomplished. Such requests for payment shall be verified and certified by the Procuring Entity’s Representative/Project Engineer. Except as otherwise stipulated in the **SCC**, materials and equipment delivered on the site but not completely put in place shall not be included for payment.

15. Operating and Maintenance Manuals

15.1. If required, the Contractor will provide “as built” Drawings and/or operating and maintenance manuals as specified in the **SCC**.

- 15.2. If the Contractor does not provide the Drawings and/or manuals by the dates stated above, or they do not receive the Procuring Entity's Representative's approval, the Procuring Entity's Representative may withhold the amount stated in the SCC from payments due to the Contractor.

DSWD-FOX

Section V. Special Conditions of Contract

DSWD-FOX

Special Conditions of Contract

GCC Clause																	
2	<p>The Intended Completion Date is as follows:</p> <table border="1" style="margin-left: auto; margin-right: auto;"> <tr><td style="text-align: center;">Lot 1</td><td style="text-align: center;">120 Calendar Days</td></tr> <tr><td style="text-align: center;">Lot 2</td><td style="text-align: center;">120 Calendar Days</td></tr> <tr><td style="text-align: center;">Lot 3</td><td style="text-align: center;">120 Calendar Days</td></tr> <tr><td style="text-align: center;">Lot 4</td><td style="text-align: center;">120 Calendar Days</td></tr> <tr><td style="text-align: center;">Lot 5</td><td style="text-align: center;">120 Calendar Days</td></tr> <tr><td style="text-align: center;">Lot 6</td><td style="text-align: center;">120 Calendar Days</td></tr> <tr><td style="text-align: center;">Lot 7</td><td style="text-align: center;">120 Calendar Days</td></tr> <tr><td style="text-align: center;">Lot 8</td><td style="text-align: center;">120 Calendar Days</td></tr> </table> <p>NOTE: The contract duration shall be reckoned from the start date and not from contract effectivity date.</p>	Lot 1	120 Calendar Days	Lot 2	120 Calendar Days	Lot 3	120 Calendar Days	Lot 4	120 Calendar Days	Lot 5	120 Calendar Days	Lot 6	120 Calendar Days	Lot 7	120 Calendar Days	Lot 8	120 Calendar Days
Lot 1	120 Calendar Days																
Lot 2	120 Calendar Days																
Lot 3	120 Calendar Days																
Lot 4	120 Calendar Days																
Lot 5	120 Calendar Days																
Lot 6	120 Calendar Days																
Lot 7	120 Calendar Days																
Lot 8	120 Calendar Days																
4.1	The Procuring Entity shall give possession of all parts of the Site to the Contractor beginning on the date of effectivity of contract until the date of its termination and/or project completion.																
6	The site investigation reports are: 1. Geodetic Survey 2. Soil Test Report																
7.2	<p><i>In case of permanent structures, such as buildings of types 4 and 5 as classified under the National Building Code of the Philippines and other structures made of steel, iron, or concrete which comply with relevant structural codes (e.g., DPWH Standard Specifications), such as, but not limited to, steel/concrete bridges, flyovers, aircraft movement areas, ports, dams, tunnels, filtration and treatment plants, sewerage systems, power plants, transmission and communication towers, railway system, and other similar permanent structures: Fifteen (15) years.</i></p> <p><i>In case of semi-permanent structures, such as buildings of types 1, 2, and 3 as classified under the National Building Code of the Philippines, concrete/asphalt roads, concrete river control, drainage, irrigation lined canals, river landing, deep wells, rock causeway, pedestrian overpass, and other similar semi-permanent structures: Five (5) years.</i></p> <p><i>In case of other structures, such as bailey and wooden bridges, shallow wells, spring developments, and other similar structures: Two (2) years.</i></p>																
10	Dayworks are applicable at the rate shown in the Contractor's original Bid.																

11.1	The Contractor shall submit the Program of Work to the Owner/Project Manager after the Design Phase, together with the design construction plans as required in Clause XI – Submittals under Section VI – Performance Specifications & Parameters of these contract Documents, but not later than 90 calendar days after receipt of the Notice to Proceed.
11.2	<p>The period between Program of Work updates is Thirty (30) days or less if the Procuring Entity requires an update.</p> <p>The amount to be withheld for late submission of an updated Program of Work is 1/50 of 1% of contract value.</p>
13	<p>The amount of the advance payment is 15% of the contract cost.</p> <p>Value can be availed of upon the submission and receipt of a request for the release of the advance payment after the issuance of the Notice to Proceed (NTP) and posting of an irrevocable letter of credit in favor of the Procuring Entity.</p>
14	<p>Progress payments shall be based on the “updated” Detailed Bill of Quantities based from the detailed cost estimates prepared and submitted by the Contractor during the Design Phase which is part of his submittals. Updating shall be limited only to minor items or sub-items not initially considered by the Contractor, but in no way shall the “updating” changes the bid amount for each particular pay item. The Bill of Quantities as submitted by the Contractor during bidding process shall serve only for that purpose and shall not in any way become the basis for payment.</p> <p>Materials and equipment delivered on the site but not completely put in place shall not be included for payment.</p>
15.1	<p>Before the <i>issuance of Certificate of Completion</i>, the Contractor shall submit “As-Built” drawings, operating and maintenance manuals as required in Item 7d under the Terms and conditions in these Bidding Documents, subject for Owner’s approval.</p> <p>Electronic versions of the As Built documents shall be in PDF and original design software formats.</p>
15.2	<p>No amount will be withheld for failing to submit “as built drawings and/or operating and maintenance manuals and warranty certificate of all equipment within the date required.</p> <p>However, such documents will form part of the requirements in processing the final payment.</p>

Section VI. Specifications

DSWD-FOX

DIVISION 1.0

GENERAL CONDITIONS

PART 1.0 GENERAL

1.1 **SCOPE OF WORK:** The work covered under this Contract consists of the furnishing all materials, labor, equipment, transportation, incidentals, facilities, and superintendence necessary to complete the project In accordance with true intent these Specifications and Contract Drawings.

1.2 **PLANS AND SPECIFICATIONS:** The Contractor shall be responsible for carefully examining, comparing and verifying the data furnished by the Plans and Specifications. In case of obscurity or discrepancy in the Plans and Specifications, the Contractor shall submit the matter to the Architect or his authorized representative for the proper explanation or necessary correction, before any adjustment shall be made. Any adjustment by the Contractor without such determination shall be at his risk and expense.

Omitted or wrongly described details of work, which are manifestly necessary to carry out the true intent of the drawings and specifications, shall be performed as if fully and correctly set forth and described in the drawings and specifications.

The Owner may, from time to time, make changes in the specifications and construction drawings. However, if the cost to the Contractor shall be materially increased by such change, the Owner shall pay the Contractor for the reasonable cost in accordance with the changes.

1.3 **LAWS TO BE OBSERVED:** The contractor shall comply with all the laws, City or Municipal Ordinances and all government Specifications and regulations in so far as they are binding upon or affecting the portion of the work hereto. The Contractor or those engaged thereon shall obtain all necessary licenses and permits and pay all taxes or fees, which may due to the local and/or National Government in connection with the prosecution of the work. He shall also be responsible for all damages to persons or property that may occur.

PART 2.0 MATERIALS

2.1 **MATERIALS:** Unless otherwise specified, all materials shall be new and free from defects and imperfections. The quality of materials shall be of the best grade of their respective kinds for the purpose. The work shall be performed in the best and most acceptable manner in strict accordance with the requirements

of the Plans and Specifications. Preference will be given to articles or materials that are locally manufactured, conditions of quality and price being equal.

- 2.2 **SAMPLES AND INFORMATION ON MATERIALS:** When required by the Specifications, or when called for by the Architect, the Contractor shall furnish, for approval, full Information and satisfactory evidence as to the kind and quality of materials or articles he will incorporate in the work. The Contractor shall furnish, for Architect's and Owner's approval, all samples when so directed. The work shall be in accordance with approved samples. Materials and articles ins-talled or used without such approval shall be at the risk of subsequent rejection.

Any failure on the part of the Contractor to conform or use materials that are not specified herein shall be under subsequent rejection. Any alteration or revision of material usage without approval from the Architect shall make the Contractor responsible and liable in terms of guarantee, workmanship and defects.

PART 3.0 WORKMANSHIP

- 3.1 **WORKMANSHIP:** Workmanship shall be in accordance with the best standard practices and all operations required under any and all parts of the Specifications shall be undertaken In a neat, workmanlike manner. Only skilled personnel with sufficient experience in similar operations shall be allowed to undertake the same.

Any alteration or revision on the execution of Drawings without approval from the Architect shall be under subsequent rejection and shall make the Contractor responsible and liable for any workmanship and execution defects.

Defective workmanship shall be remedied by the Contractor, at his expense. He shall not be entitled to any payment hereunder until defective workmanship has been remedied.

- 3.2 **TEMPORARY FACILITIES:** The Contractor shall provide and maintain adequate weather-tight temporary facilities with water, light, and toilet facilities. He shall keep such places clean and free from flies. He shall remove all connections and appliances connected there with prior to the completion of the Contract and leave the premises perfectly clean.

The Contractor shall furnish all temporary lights and power and shall pay all expenses in connection therewith. Furthermore, the Contractor shall provide and

pay for all water expenses for building purposes that are required by all trades.

- 3.3 PROTECTION OF WORK AND OWNER'S PROPERTY: The Contractor shall put up safety measures and continuously maintain adequate protection of all his work from damage and shall protect the Owners property, as well as all materials furnished and delivered to him by the Owner. He shall make good any such damage, injury or loss, except such as may be caused by agents or employees of the Owner, or due to causes considered as an Act of God.

PART 4.0 SUPERVISION AND INSPECTION

- 4.1 AUTHORIZED REPRESENTATIVE: Whenever the Contractor is not at the site, orders maybe given by the Owner to his authorized representative and shall be accepted and complied to by the superintendent or foreman of the Contractor.

- 4.2 INSPECTION OF WORK: The Architect or Owner shall, at all times, have access to the work whenever it is in preparation or progress and the Contractor shall provide facilities for such access for inspection. The manner of work and all materials and equipment used therein shall be subject to inspection, tests, and approval of the Owner.

- 4.3 CONSTANT SUPERVISION. The Contractor shall ensure that the project will have constant supervision by a competent superintendent, who shall be present where construction is being carried on at all times during the working hours.

- 4.4 DISPUTES: The Architect shall, within a reasonable time, make decision on all claims of the Owner or Contractor and on all matters relating to the execution and progress of the work or the interpretation of the Contract Documents.

Except as otherwise specifically provided in this Contract, all disputes concerning questions of fact arising under this contract shall be decided by the Architect, whose decisions shall be final and conclusive upon the parties as to questions of fact.

- 4.4 CLEAN UP: The Contractor, prior to the turnover of the work to the Owner, shall remove any excess materials, waste, debris, rubbish, and all construction and installation equipment and tools from the premises.

END OF SECTION

DIVISION 2.0 SITEWORK

SECTION 2.01 EARTHWORK

PART 1.0 GENERAL

1.1 **WORK INCLUDED:** Work in this section includes the complete clearing of site, general site grading, excavating, filling and backfilling.

PART 2.0 DEGREE OF COMPACTION

Required compaction is expressed as a percentage of the maximum density obtained by test procedure of ASTM D1557.

2.1 **EXCAVATION.** The contractor shall perform excavation of every type of material encountered within the limits of the project to the lines, grades, and elevations indicated and as specified herein. Grading shall be in conformity with the typical sections shown and shall be finished within a tolerance of 25/100 foot of the grades indicated. Satisfactory excavated materials shall be transported to and placed in fill areas within work limits. Unsatisfactory materials encountered below the established sub-grade shown under building or paved areas shall be excavated 300 mm or 31 cm below grade and replaced with satisfactory materials as directed. In the event that it is required to remove unsatisfactory material to a greater depth than specified, an adjustment in the contract price will be made in accordance with the contract. Surplus satisfactory excavated material not required for fill or embankment shall be disposed of to the designated waste or spoil areas. Unsatisfactory excavated material shall be disposed of in designated wastes or spoil areas. Excavation and filling shall be performed in manner and sequence that will provide proper drainage at all times.

2.2 **CUTTING, FILLING AND GRADING.** Cutting, filling and grading will be done to bring all areas of the respective surfacing as fixed by the finished grade.

2.3 **COMPACTION.** Compaction shall be by rolling with approved tamping rollers, vibratory rollers, pneumatic-tired rollers, three-wheel power rollers, or other approved equipment well suited to the particular soil being compacted. Material shall be moistened or aerated as necessary to provide the moisture content that will facilitate obtaining the specified compaction with the equipment utilized. 0

2.4 **SUB-GRADE PREPARATION**

a. **CONSTRUCTION.** Sub-grade shall be shaped to line, grade, and cross-section, and compacted as specified. This shall be done by plowing, disking, and moistening or aerating. Low areas resulting from removal of

unsatisfactory material or excavation of rock shall be brought up to required grade with satisfactory materials, and entire sub-grade shaped. Elevation of finish sub-grade shall conform to elevations shown.

- b. PROTECTION. During construction, any excavation shall be kept shaped and drained. Ditches and drains shall be maintained in such manner as to drain effectively at all times. Graded areas shall be protected against action of the elements prior to acceptance of the work. Settlement or washing that may have occurred shall be repaired and grades shall be re-established to the required elevations and slopes immediately prior to installation of paving.

2.5

EXCAVATION, FILLING, AND BACKFILLING FOR BUILDING

- A. GENERAL. Excavations shall conform to dimensions and elevations indicated for the building structure, and shall extend a sufficient distance from walls and footings to services, except where the concrete for walls and footings is authorized to be deposited directly against excavation surfaces. Bottoms of all footings shall be on level planes.
- B. EXCESS EXCAVATION. Excavations carried below indicated depths will not be permitted except to remove unsatisfactory material. Unsatisfactory materials encountered below grades shown shall be removed and replaced as directed with satisfactory materials. Unauthorized material removed below depths indicated shall be replaced, at no additional cost to the owners, to the indicated excavation grade with satisfactory materials placed and compacted to 100% maximum density except under concrete footings.
- C. DRAINAGE AND PUMPING. Excavate in such a manner that site and area immediately surrounding will be continually drained. Water shall not be permitted to accumulate in excavations. Do all necessary pumping required to keep excavations dry.
- D. SHORING. During excavation shall be furnished and installed as necessary to protect workers, banks, adjacent paving, structures, and utilities. Shoring, bracing, and sheeting shall be removed, as excavations are backfilled in such a manner as to prevent injurious caving.
- E. EXCAVATED MATERIALS. Satisfactory excavated materials required for fill or backfill shall be separately stockpiled as directed. Unsatisfactory and surplus excavated materials not required for fill and backfill shall be disposed of in designated waste area. Stockpiles and wasted materials shall be graded and sloped for proper drainage.
- F. BACKFILLING. Backfilling shall not begin until construction below finish grade has been approved, underground utilities systems have been inspected, tested, and approved, forms removed, and the excavation cleaned of trash and debris. Backfill shall be brought to indicate finish sub-grade. Backfill materials shall be satisfactory materials, free from roots and other organic matter, trash, debris. Place backfill in 23-cm maximum layers loose depth. Compaction shall be as in Paragraph

2A.5. Fill shall be compacted by power-driven hand tampers suitable for the material being compacted. Backfill shall not be placed against foundation walls prior to 7 days after placement of concrete or masonry. As far as practicable, backfill shall be brought up evenly on each side of the wall and sloped to drain away from the wall. Brace inside of the wall before backfill is placed on the outside of basement.

- G. PROTECTION. Settlement that occurs in backfill areas prior to acceptance of the work shall be repaired and grades re-established to the required elevation and slope.

2.6

EXCAVATION, TRENCHING AND BACKFILLING FOR UTILITIES

- A. GENERAL. Perform all excavating of every description and of whatever substance encountered to depths indicated or specified. Pile materials suitable for backfilling a sufficient distance from banks of trenches to prevent slides or cave-ins. Excavated materials shall be piled to one side only of trenches and in such a manner as to permit ready access to and use of existing utilities system. All excavated materials not required or suitable for backfill shall be wasted as directed. Water shall be removed by pumping or other approved method and shall be discharged at a safe distance from the excavation. Sheeting and shoring shall be done as necessary for protection of work and for safety of personnel.
- B. TRENCH EXCAVATION. Trenches shall be of necessary width for proper laying of pipe, while concrete lining, duct, or cable, and banks shall be as nearly vertical as practicable. Trench excavation shall be coordinated to avoid open trenches for prolonged periods. Bottoms of trenches shall be accurately graded to provide uniform bearing and support for each section of pipe on undisturbed soil at every point along its entire length, except for portions of pipe sections where it is necessary to excavate for bell holes and for proper making of pipe joints.
- C. BACKFILLING. Backfilling shall be coordinated with testing of utilities. Where damage is likely to result from withdrawing sheeting, it shall be left in place and contract price will be adjusted accordingly. Trenches shall be carefully backfilled with satisfactory materials, consisting of earth, loam, sandy clay, sand and gravel, or soft shale, free from large clod of earth. Backfill shall be brought up evenly on both sides of pipe for a cover of not less than 31 cm for storm drains. The remainder of backfill material shall then be deposited in the trench in 31-cm maximum layers and compacted by mechanical means. Trenches and excavation pits improperly backfilled, or where settlement occurs, shall be reopened to the depth required for proper compaction, then refilled and compacted, with the surface restored to the required grade and compaction.

END OF SECTION

DIVISION 3 CONCRETE

SECTION 3.01 CAST-IN-PLACE CONCRETE

PART 1 GENERAL

1.1 SCOPE. This section covers cast-in-place concrete, complete. __

1.2 DELIVERY AND STORAGE

- a. CEMENT. Cement shall be stored immediately upon receipt at the site of the work in a suitable weatherproof and airtight structure and elevated above the ground to prevent the absorption of moisture. Bags shall be stacked close together to reduce circulation of air, but shall not be stacked against outside walls. The manner of storage shall permit easy access for inspection and identification of each shipment. Bulk cement shall be transferred to elevated airtight and weatherproof bins. At the time of use, all cement must be free flowing, and free of lumps. Cement that has been in storage for longer than 6 months will be tested by standard mortar tests or other test as deemed necessary by the Construction Architect or Engineer to determine its suitability for use.
- b. AGGREGATES. Aggregates shall be stored in areas covered with tightly laid wood planks, sheet metal or other hard and clean surface, and in a manner that will preclude the inclusion of foreign materials. Aggregates of different sizes shall be stored in separate piles.
- c. REINFORCEMENT. Reinforcement shall be stored in such a manner that will prevent excessive rusting or coating with grease, oil, dirt, and other objectionable materials. Storage shall be in separate piles or racks to avoid confusion and loss of identification after bundles have been broken.

PART 2.0 MATERIALS

2.1 CEMENT Portland cement shall conform to PNS 07, type 1. Cement for exposed concrete surfaces shall be from the same mill.

2.2 REINFORCEMENT. All reinforcing steel bars, except No. 2, shall be deformed. The manufacturer shall submit certification of compliance to this specification prior to the delivery of these materials.

2.3 FINE AGGREGATES. Fine aggregates shall be clean, hard, natural sand or manufactured sand, or a combination of both.

- 2.4 COARSE AGGREGATES. Coarse aggregates shall be hard, durable, uncoated gravel, crushed gravel, or a combination thereof.
- 2.5 WATER. Mixing water for concrete shall be fresh, clean, and potable.
- 2.6 CURING MATERIALS. Materials shall conform to one of the following unless otherwise designated:
- a. Polyethylene sheeting for curing, 6 mils minimum thickness, clear.
 - b. Waterproof Kraft paper or polyethylene-coated waterproof paper for concrete curing shall be of commercial quality.
 - c. Burlap, plain or polyethylene-coated burlap shall be of commercial quality.
- 2.7 EXPANSION JOINT'S FILLER shall be elastomeric pre-molded type.
- 2.8 SEALING MATERIALS for expansion joints shall be single component urethane or acrylic type sealant.
- 2.9 FORMS COATING shall be non-staining type mineral oil.
- 2.10 VAPOR BARRIER shall be a polyethylene sheet, 6 mils minimum thickness, clear, conforming to commercial standard CS-238.
- 2.11 WATER - STOP shall be rubber, neoprene or PVC

PART 3.0 FORMS

- 3.1 GENERAL REQUIREMENTS. Forms shall be provided for all concrete. Forms shall be set true to line and grade and maintained as to ensure completed work within the allowable tolerance specified, and shall be mortar-tight. The contractor shall be responsible for the adequacy of forms and form support. Wire ties shall not be used where the concrete surface will be exposed to weathering and where discoloration will be exposed. All formwork shall be provided with adequate clean-out openings to permit inspection and easy cleaning after all reinforcement has been placed. Where forms for continuous surfaces are placed in successive units, these shall be fitted over the completed surface to obtain accurate alignment of the surface and to prevent leakage of mortar. Panel forms shall be constructed to provide tight joints between panels. All forms shall be constructed so that they can be removed without damaging the concrete. All exposed joints, edges and external corners shall be chamfered a minimum of 20 mm unless specified otherwise hereinafter.
- 3.2 MATERIALS FOR FORMS. Forms shall be of wood, plywood, steel, or other suitable materials. Wood forms for surfaces exposed to view in the

finished structure and requiring a standard finish, shall be plywood. For unexposed surface, undressed square-edged lumber may be used. Forms for surfaces requiring special finishes shall be plywood or hard-pressed fiberboard not less than 12 mm thick. Surfaces of steel forms shall be free from irregularities, dents, and sags.

3.3 COATING. Before placing the concrete, the contact surfaces of forms shall be coated with non-staining mineral oil or suitable non-staining form coating compound, or shall be given two coats of nitrocellulose lacquer, except as specified otherwise. Mineral oil shall be used on forms for surfaces, which are to be painted. For surfaces not exposed to view in the finished structure and when temperature is above 40 degrees F, sheeting may be wetted thoroughly with clean water. All excess coating shall be removed by wiping with cloths. Re-used forms shall have the contact surfaces cleaned thoroughly; those, which have been coated, shall be given an additional application of the coating. Plaster waste molds shall be sized with two coats of thin shellac or lacquer and coated with soft or thinned non-staining grease.

3.4 TOLERANCE AND VARIATIONS. The contractor shall set and maintain concrete forms to insure that after removal of the forms and prior to patching and finishing, no portion of the concrete work will exceed any of the tolerances specified. Variation in floor levels shall be measured before removal of supporting shore. The contractor shall be responsible for variations due to deflection. The specified variation for one element of the structure will not be applicable when it will permit another element of the structure to exceed its allowable variations. Except as otherwise specified hereinafter, tolerances.

PART 4 CLASSES OF CONCRETE

4.1 STRENGTH REQUIREMENTS. Concrete of the various classes, if not indicated in the drawings and as specified under other sections, shall be proportioned and mixed for the following strengths:

CLASS A	SPECIFIED COMPRESSIVE STRENGTH, 28 Days, Psi	CLASS	SPECIFIED FLEXURAL STRENGTH 28 Days, Psi
AA	4,000	P	600
A	3,000		
B	2,500		
C	2,000		

Concrete made with high-early-strength cement shall have a 7-day strength equal to the specified 28-day strength for concrete of the class specified made with type I or II Portland cement

4.2 USAGE. Concrete of the various classes shall be used as follows:

- a. Class AA concrete - For water storage tanks, septic tanks and other work as indicated.
- b. Class A concrete - For pre-cast concrete items, slabs, beams, and walls above grade, columns, stairs, lintels, and for all reinforced work not otherwise indicated or specified.
- c. Class B concrete - For slabs and grade, grade and tie beams, footings, and for such concrete work as indicated or specified.
- d. Class C concrete - For all concrete not reinforced except as otherwise indicated or specified.
- e. Class P concrete - For slabs on grade subject to vehicular load and as indicated or specified.

PART 5 PROPORTIONING, MEASUREMENT AND MIXING

5.1 CONCRETE DESIGNS MIX. Concrete mixes except otherwise indicated shall be designed by the contractor. The proportions shall be changed whenever necessary to maintain the workability, strength, and standard of quality core the concrete covered by these specifications, and to meet the varying conditions encountered during construction. Test for slump and unit weight shall be performed under the supervision of the Construction Architect/Engineer.

5.2 SLUMP shall be determined in conformance with ASTM C 143, and shall be within the following limits, provided the required strength is obtained:

STRUCTURAL ELEMENT	SLUMP FOR VIBRATED CONCRETE	
	Minimum	Maximum
Walls, columns, and grade beams, 250 mm. Maximum thickness	75 mm.	100 mm.
Other construction	50 mm.	75 mm.

5.3 PROPORTIONING OF MATERIALS shall be accomplished by weighing, except as otherwise provided herein. In urgent situation, volumetric proportioning may be used temporarily, if permitted by the Construction Architect/Engineer, who will stipulate the length of the period during which volumetric proportioning may be used. The contractor shall furnish the necessary equipment and shall establish accurate procedures for determining the quantities of free moisture in the aggregates, the true

volume of the fine aggregate if volumetric proportioning is used, and the air content of the freshly mixed concrete if air-entrained concrete is used. Such procedures are subject to the approval of the Construction Architect/Engineer. Moisture, volumetric and air determinations shall be made at intervals as directed by the Construction Architect/ Engineer and as specified hereinafter under field testing requirements. Allowable tolerances for measuring cement and water shall be one (1%) percent; for aggregates, two (2%) percent; and three (3%) percent for mixtures.

- 5.4 **WEIGHT MEASUREMENT.** The fine aggregate and each size of coarse aggregate shall be weighed separately. Cement in standard packages (bags) need not be weighed, but bulk cement or fractional packages shall be weighed on a scale separate from that used for weighing other materials.
- 5.5 **VOLUMETRIC MEASUREMENT.** The weight proportions shall be transposed into equivalent volumetric proportions by weighing representative samples of the aggregates in the conditions in which they will be measured and in accordance with ASTM C29. In determining the true volume of the fine aggregate, allowance shall be made for the bulking effect from the moisture contained therein. Suitable allowances shall also be made for variations in the moisture conditions of the aggregates.
- 5.6 **MIXING.** All concrete shall be machine-mixed. In cases of emergency or small batches, the mixing may be done by hand if so authorized by the Construction Architect/ Engineer. Mixing shall begin within 30 minutes after the cement has been added to the aggregates. The time of mixing after all cement and aggregates are in the mixer drum shall be not less than one minute for mixers having a capacity of one cubic yard or less; for mixers of larger capacities, the minimum time shall be increased 15 second for each additional cubic yard. A reduction in the aforementioned mixing time shall be permitted if mixer performance tests made at the contractor's option and at his expense, indicate adequate mixing with the reduced time. All mixing water shall be introduced in the drum before one-fourth of the mixing time has elapsed. The entire content of the mixer drum shall be discharged before recharging. The time elapsing between the introduction of the mixing water to the cement and aggregates or the cement to the aggregates and placing of the concrete in final position in the forms shall not exceed 60 minutes, if the air temperature is less than 85 degrees Fahrenheit. If the air temperature is equal or greater than 85 degrees Fahrenheit, time elapsed shall not exceed 45 minutes. The re-tampering of concrete, i.e., re-mixing with or without additional cement, aggregate or water, will not be permitted.
- 5.7 **READY-MIXED CONCRETE.** Ready-mixed concrete is defined in this specification as concrete produced regularly by a commercial establishment and delivered to the purchaser in the plastic state. Subject to the approval of the Construction Architect/Engineer, ready-mixed concrete may be used provided that (a) the plant has sufficient capacity and transportation

equipment to deliver the concrete at the rate desired, and (b) the plant meets the requirements specified for equipment, measurement of materials, and mixing. The cement, aggregates, water and admixtures shall conform to all applicable requirements of this specification. Ready-mixed concrete not specified otherwise hereinafter shall be mixed and delivered by means of the following methods:

- a. **TRUCK MIXING** Concrete shall be mixed and delivered in a truck mixer. Mixers shall be charged with a ribbon-fed mixture of aggregates and cement, or in the absence of facilities for ribbon feeding, the aggregates shall be charged before the cement. When mixing has begun during or immediately after charging, a portion of the mixing water not in excess of that required to produce the minimum acceptable slump shall be added ahead of or with the other ingredients. Total mixing shall not be less than 50, but not more than 100 revolutions of the drum at the manufacturer's rated mixing speed after all ingredients, including water, are in the drum. After 30 to 75 revolutions of the drum, the slump shall be tested and additional water shall be added if necessary to produce the required slump; if additional water is necessary, mixing shall be continued for at least 20 revolutions of the drum after the water is added. Mixing speed shall not be less than rpm for revolving drum mixers, and not less than 4 rpm nor more than 16 rpm for open-top mixers. Any turning of the drum during transportation shall be at the speed designated by the manufacturer of the equipment, as agitating speed. Each batch of concrete delivered at the job site shall be accompanied by a time slip issued at the batching plant, bearing the time of departure therefrom and the signature of the inspector. Discharge of concrete from the drum shall be completed within 1 hour or before the drum completes 250 revolutions after the introduction of water to the cement and aggregates.
- b. **COMBINATION CENTRAL PLANT AND TRUCK MIXING.** (Shrink Mixing). Concrete shall be partially mixed in a central plant mixer and the mixing completed in a truck mixer. The mixing time in a central plant mixer shall be the minimum required to intermingle the ingredients and shall not exceed 30 seconds. The mixing shall be completed in a truck mixer as specified herein before under truck mixing.
- c. **CENTRAL PLANT MIXING.** Concrete shall be mixed completely in a stationary mixer at a plant and transported to the site of the work in a truck agitator or a truck mixer operating at a speed of rotation designated by the manufacturer as agitating speed. Mixing shall begin within 30 minutes after cement has been added to aggregates. When authorized in writing by the Construction Architect/Engineer non-agitation equipment approved by him may be used for transporting concrete. The time lapse between the introduction of the mixing water to the cement and aggregates and the placing of concrete in final position in the forms shall

not exceed: (a) for agitating equipment - 60 minutes, if air temperature is less than 80 degrees F. or 45 minutes, if air temperature is equal or greater than 85 degrees F., (b) for non-agitating equipment - 30 minutes.

d. **CONSISTENCY OF CONCRETE.** Except as specified otherwise, the slump shall be from 50 mm to 100 mm.

PART 6 PLACING REINFORCEMENTS AND MISCELLANEOUS MATERIALS

6.1 **GENERAL REQUIREMENTS.** All reinforcement bars, stirrups, hanger bars, wire fabric, spiral, and other reinforcing materials shall be provided as indicated on the drawing or required by this specification, together with all necessary wire ties, chairs, spaces, supports and other devices necessary to install and secure the reinforcement properly. All reinforcement, when placed, shall be free from rust, scales, oil, grease, clay, and other coatings, and foreign substances that would reduce or destroy the bond. Rusting of reinforcement shall not be a basis of rejection, provided that the rusting has not reduced the effective cross sectional area of the reinforcement to the extent that the strength is reduced beyond specified value. Heavy, thick rust or loose, flaky rust shall be removed by rubbing with burlap or other approved method, prior to placing. Reinforcement, which has bends not shown on the project drawings, approved shop drawings, or is reduced in section by rusting such that its weight is not within permissible ASTM tolerances, shall not be used. All reinforcement shall be supported and wired together to prevent displacement by construction loads or by the placing of concrete. Unless directed otherwise by the Construction Architect/Engineer, reinforcement shall not be bent after being partially embedded in hardened concrete. Where cover over reinforcing steel is not specified it shall be in accordance with ACI 318.

6.2 **PLACING.** Reinforcement shall be placed accurately and secured. It shall be supported by suitable chairs or spacers or by metal hangers. On the ground, and where otherwise subject to corrosion, concrete or other suitable non-corroding material shall be used for supporting reinforcement. Where the concrete surface will be exposed to the weather in the finished structure or where rust would impair the appearance or finish of the structure, all reinforcement supports, within specified concrete cover, shall be galvanized or made of a suitable non-corroding material.

6.3 **SPLICING OF REINFORCEMENT.** Splicing of reinforcement shall be in accordance with ACI 318, except as indicated otherwise or modified herein. Where splices in addition to those indicated on the drawings are necessary, they shall be approved by the Construction Architect/Engineer prior to their use. Splices shall not be used in grade beams and slabs at points of maximum stress. Except as indicated or specified otherwise herein, in lieu of lapping, but splicing of reinforcement may be permitted provided the

splicing material, equal or greater in cross sectional area to the spliced steel, shall possess a minimum of 125 percent of the yield strength or 90 percent of the ultimate strength of the reinforcing steel, whichever is the greater. But splicing shall preferably use over lapping for bar sizes No. 11 and above.

6.4 MOVING REINFORCING STEEL. All placement or movement of reinforcing steel after placement to positions other than that indicated or specified shall be subject to the approval of the Construction Architect/Engineer.

6.5 SETTING MISCELLANEOUS MATERIAL. Anchors and bolts, including, but not limited to those for machine and equipment bases, frames or edgings, hangers and inserts, door bucks, pipe supports, pipe sleeves, metal ties, conduits, drains and all other materials in connection with concrete construction, shall, where practicable, be placed and secured in position when the concrete is placed. Anchor bolts for machines shall be set to templates, plumbed carefully and checked for location and elevation with an instrument, and shall be held in position rigidly to prevent displacement while concrete is being placed.

PART 7 CONVEYING AND PLACING CONCRETE

7.1 CONVEYING. Concrete shall be conveyed from the mixer to the forms as rapidly as practicable by proper methods, avoiding segregation or loss of ingredients. It shall be deposited as nearly as practicable in its final positions in the forms. At any point in the conveying, the free vertical drop of the concrete shall not exceed 91 cm. Chuting will be permitted only where the concrete is deposited into a hopper before it is placed in the forms. Conveying equipment shall be cleaned thoroughly before each run. All concrete shall be deposited as soon as practicable after the forms and reinforcements have been inspected and approved by the Construction Architect/Engineer. Concrete, which has been segregated in conveying, shall be removed and disposed of as directed by the Construction Architect/Engineer.

7.2 PLACING CONCRETE. No concrete shall be placed after there is evidence of initial set. All concrete placing equipment and methods shall be subject to approval of the Construction Architect/Engineer. Concrete placement will not be permitted when weather conditions prevent proper placement and consolidation. Before placing concrete on porous sub-grades, they shall be dampened as directed by the Construction Architect/Engineer. Forms shall be clean and free from dirt, construction debris and water. Concrete shall be deposited in horizontal layers approximately 31 to 51 cm deep in a manner to preclude the formation of cold joints between successive layers. The method of depositing concrete shall be such as to avoid displacing the reinforcement and segregating the aggregate. Concrete shall be worked

about the reinforcement and embedded fixtures and avoid overworking which may result in segregation. On the bottom of slabs, the girders where the congestion of steel near the forms makes placing difficult, a layer of mortar equal to the approved slump shall be deposited to cover the surface to a depth of approximately 25 mm before placing the concrete. Water, which accumulates on the surface of the concrete during placing, shall be removed by absorption with porous materials in a manner that prevents removal of cement. Pumping of concrete through aluminum pipe shall not be permitted.

7.3 VIBRATION. All concrete, except for concrete slabs 100 mm or less in depth, shall be compacted using high frequency, internal, mechanical vibrating equipment supplemented by hand spading and tamping. Concrete slabs 100 mm or less in depth shall be consolidated by wood tamper, and spading and settling with a heavy leveling straight edge. Vibrator shall be designated to operate with vibratory element submerged in the concrete and shall have a frequency of not less than 6,000 impulses per minute when submerged. The vibrating equipment shall be adequate at all times in number units' power of each unit to consolidate the concrete properly. Vibration of forms and reinforcement shall not be employed except when authorized specifically the Construction Architect/Engineer. Vibrators shall not be used to transport the concrete in the forms. Vibration shall be discontinued when the concrete has been compacted thoroughly and ceased to decrease in volume.

7.4 CONSTRUCTION JOINTS. Joints not shown on the drawings shall be made and located so as to least impair the strength of the structure and shall be subject to approval of the Construction Architect/Engineer. In general, they shall be located near the middle of the spans of slabs, grade beams. Horizontal joints in walls shall be at the underside of floor, slabs, grade beams, or girders and at the top of footings or grade slabs. Grade beams, brackets, and drop panels shall be placed at the same time as slabs. Joints shall be perpendicular to the main reinforcement. All construction joints in contact with the grade or earth shall be provided with an approved type rubber or PVC water-stop to minimize water leakage. Water-stop shall be installed so as to form a continuous watertight diaphragm. Joints and splices shall be vulcanized or heat-sealed and as recommended by the manufacturer as approved.

a. Reinforcement in construction joints. All reinforcing steel shall be continued across joints. Keys and inclined dowels shall be provided as directed by the Construction Architect/Engineer. Longitudinal keys at least 38 mm deep shall be provided in all joints in walls and between walls and slabs or footings.

7.5 EXPANSION JOINTS AND CLEAVAGE JOINTS.

- a. Expansion joints and cleavage joints shall not be less than 12 mm wide except as indicated otherwise. Expansion joints not exposed to weather shall be filled completely with pre-formed joint materials. Expansion joints exposed to weather and cleavage joints between vertical masonry surfaces and floor slabs lay on earth shall be filled to a depth of 25 mm from the surface or face of the concrete with pre-formed joints' material. The 25-mm deep space above the performed material shall be cleaned after the concrete has been cured, and when dry, filled with flush with joint-sealing material. Reinforcement or the embedded metal items bonded to the concrete shall not be permitted to extend continuously through any expansion joints.
- b. Sealing materials for expansion joints shall be single component urethane sealant or equal.
- c. Other embedded items. All sleeves, inserts, anchors, and embedded items required for adjoining work or for its support shall be placed prior to concreting. All subcontractors whose work is related to the concrete supported by it shall be given ample notice and opportunity to introduce or furnish embedded item before the concrete is placed. All ferrous metal sleeves, inserts, anchors and other embedded ferrous items exposed to the weather or where rust would impair the appearance of finish or the structure shall be galvanized.

7.6 PLACING EMBEDDED ITEMS. Expansion joint material and embedded items shall be positioned accurately and supported against displacement. Voids in sleeves, inserts and anchors' slab shall be filled temporarily with readily removable material to prevent the entry of concrete into the voids.

7.7 PLACING CONCRETE IN HOT WEATHER. Placing concrete in hot weather shall be in accordance with ACI305 except as modified herein. In hot weather, extra care shall be taken to reduce the temperature of the concrete being placed, and to prevent rapid drying of newly placed concrete. When the outdoor ambient temperature is more than 90 degrees F., the fresh concrete shall be shaded as soon as possible after the placing and curing shall be started as soon as the surface of the fresh concrete is sufficiently hard to permit it without damage.

PART 8 SLABS ON GRADE.

8.1 VAPOR BARRIER. Immediately prior to placing concrete, the capillary water barrier or sub-grades under slabs within the building shall be covered with vapor barrier. Puncture and tear shall be patched. Edges shall be lapped not less than 100 mm and end joints shall be lapped not less than 150 mm. Edges and lapped joints shall be sealed with a pressure-sensitive tape, not less than 50 mm wide, compatible with the membrane.

PART 9

SURFACE FINISH (EXCEPT FLOOR FINISH)

- 9.1 **GENERAL REQUIREMENTS.** All formed surfaces shall be repaired by patching with cement mortar. Cement mortar for patching shall be the same composition as that used in the concrete, except that for exposed surfaces' part of the cement shall be white Portland cement to provide a finish color matching the surrounding concrete. Patching shall be done as soon as the forms are removed area to surfaces which are to be cured with a curing compound shall be covered during the application of the compound. All areas to be patched shall be cleaned thoroughly. Minor honeycomb or otherwise defective areas shall be cut out to solid concrete but to a depth of not less than 25 mm. The edges of the cut shall be perpendicular to the surface of the concrete. The area to be patched and at least 150 mm adjacent hereto shall be saturated with water before placing the mortar. The mortar shall be mixed approximately one hour before placing and shall be re-mixed occasionally during this period with a trowel without the addition of water. A grout of cement and water mixed to a consistency of paint shall then be brushed on to the surfaces to which the mortar is to be bonded. The mortar shall be compacted into place and screeded slightly higher than the surrounding surface. Patches on exposed surface shall be finished to match the adjoining surfaces, after they have set for an hour or more. Patches shall be cured as specified for the concrete. Holes extending through the concrete shall be filled by means of a plunger type gun or other suitable device from the unexposed fact. The excess mortar shall be wiped off the exposed face with a cloth. Finished surfaces shall be protected from stains and abrasions. Standard finish against steel, plywood and wood forms shall be equal in workmanship, texture and general appearance to that of approved sample panels. Concrete with excessive honeycombing, which exposes the reinforcing steel or other defects affecting the structural strength of the member will be rejected and the defects shall be corrected as directed by the Construction Architect/Engineer, and at the expense of the contractor.
- 9.2 **RUBBED-FINISH.** Rubbed-finish shall be provided for all exposed concrete beams and ceiling. The surface of the concrete shall not vary more than 16 mm when measured from a five-foot template. Exposed surfaces shall be rubbed with carborundum or other abrasives to a smooth even finish or uniform appearance. Upon completion of the rubbing, the surface shall be washed thoroughly with clean water.
- 9.3 **BROOM-FINISH.** Broom-finish shall be given to exterior parking area or as approved. The concrete shall be screeded and floated to the required finish level with no coarse aggregate visible. After the surface moisture has disappeared and laitance has been removed, surface shall be steel-trowelled to an even, smooth finish. The trowelled surfaces shall be broomed with a fiber-bristle brush in a direction traversing to that of the main traffic.

PART 10

FLOOR FINISHES

10.1 GENERAL REQUIREMENTS. The finishes included herein shall be surface finishes and treatments for floor slab. Concrete toppings except where indicated shall not be allowed for all floor slabs having steel-trowel finish. For roof deck floors in which drains occur, special care shall be exercised to slope the floors uniformly to the drains. Deck roof floors shall receive single steel trowelling prior to the application of waterproofing.

10.2 PLACING AND SCREEDING NORMAL CONCRETE SLAB OR BASE SLAB. Concrete of slump within the limits specified herein before shall be placed, consolidated and immediately struck off to bring the top surface of the slab to proper contour, grade elevation. This operation may be followed immediately by a darbying or bull floating of the surface with wooden tools so as to correct any unevenness. Striking off and darbying shall be completed before bleed water appears on the surface of the freshly placed concrete. No further work shall then be performed until the concrete has attained a set sufficient for floating and sufficient to support the weight of the finisher and/or equipment. If the bleed water has not disappeared by the time floating of the surface is to start, the excess water shall be first dragged off on the surface by using a rubber hose. At no time shall dry cement will be used to absorb bleed water.

- a. ROUGH-FINISH. Shall be provided for all floors to receive future floor finish, which will be provided by tenants. Allow 50 mm below finish floor line.
- b. NON-SLIP FINISH shall be provided for ramps allocated for disabled persons. Type of finish shall be as approved.

10.3 CLEANING Upon completion of the work, all concrete floors shall be cleaned as follows: after sweeping with an ordinary broom to remove the loose dirt, the finish surface shall be wetted with soap suds and rubbed with a scrubbing machine fitted with a wire brush or fine steel wool. The suds shall be mopped up, and the surface shall be flushed with clean warm water, after which a final scrubbing by hand instead of the machine scrubbing will be permitted when authorized specifically.

PART 11 CURING

11.1 GENERAL REQUIREMENTS. Curing for all concrete shall be accomplished by preventing loss of moisture, rapid temperature change, mechanical injury, or injury from rain or flowing water for a period of 7 days when normal Portland cement has been used. Curing shall be started as soon after placing and finishing as free water has disappeared from the surface of the concrete. Curing may be accomplished by any of the following methods or combination thereof, as approved.

11.2 **MOIST CURING.** Unformed surfaces shall be covered with burlap or other approved fabric-type mats and shall be kept continually wet. Forms shall be kept continually wet. If forms are removed before the end of the curing period, curing shall be continued on unformed surfaces that will be unexposed in the finished work.

11.3 **IMPERVIOUS SHEET CURING.** Surfaces shall be covered with waterproof paper, polyethylene coated waterproof paper or burlap, or polyethylene sheets, lapped 100 mm at edges and ends, and sealed with an adhesive tape suitable for the type of covering used. The covering shall be weighed to prevent displacement, and kept in place and in repair during the curing period.

11.4 **CURING PERIODS.** When 7-day compression test cylinders, representative of parts of a structure already placed, indicate that the 28-day strengths may be less than 90% of the design strengths, those parts of the structure shall be given additional curing, as directed by the Construction Architect/Engineer. Curing shall be as follows:

TIME (Minimum)	CONCRETE ELEMENT
7 Days	All concrete not specified otherwise
10 Days	Pavement not undercover

11.5 **REMOVAL OF FORMS AND PROTECTION.** Forms shall be removed in a manner, which will prevent damage to the concrete. Forms shall not be removed without approval of the Construction Architect/Engineer.

PART 12 SAMPLING

12.1 **CONCRETE.** The strengths specified and the design mix shall be verified during the progress of the work at intervals by testing standard cylinders of samples taken at the job site.

Three test cylinders shall be taken for each 60 cubic meter or fraction thereof of each class of concrete placed, but at least test cylinders shall be taken each day for each class of concrete placed that day, or as directed by the Construction Architect/Engineer. No more than 3 cylinders shall be taken from any one batch. The contractor shall furnish the necessary labor, materials, and facilities for taking the samples, handling, storing the cylinders at the site of the work, and shipping the cylinders for testing to the authorized and designated testing laboratory at his expense.

12.2 **SAMPLE IDENTIFICATION.** Each sample shall be contained in a clean container, which shall be securely fastened to prevent loss of material. It shall be tagged for identification. The tag shall contain the following information: (1) Contract No., (2) Sample No., (3) Quantity, (4) Date

Sample was taken, (5) Sampler, and (6) Intended Use.

12.3

CONCRETE TESTING.

- a. Testing consistency of concrete slump shall be determined in accordance with ASTM C143. Samples for a slump determination will be taken from the concrete during placing in the forms. Tests shall be made.
- b. Tests shall likewise be made at the beginning of a concrete placement operation and at subsequent intervals to insure that the specification requirements are met.
- c. Concrete testing shall also be done whenever test cylinders are made.
- d. Testing of specimens for compressive strength shall be in accordance with ASTM C39. Test will be made at 7 and 28 days from time of molding. When a satisfactory relationship between 7- and 28-day strengths has been established, the 7-day tests' results may be used as an indicator of the 28-day strength. Each test shall be the average of the strengths of the three test specimens of a set except that if one specimen in a set of three shows evidence, other than low strength, or improper sampling, molding, handling, or curing, the remaining two specimens shall be considered the test result. No more than 10 percent of the cylinders tested shall have compressive strengths less than that specified.

12.4

CONTRACTOR-FURNISHED MIX DESIGN. If test results of any concrete to be used in the project show that the concrete strength is below the specified limits and does not meet other requirements of this specification, the contractor shall make all necessary adjustments, as directed by the Construction Architect/Engineer at the Contractor's expense. Concrete, which, at the end of 28 days, does not meet the specified strength, shall be removed or otherwise corrected at the Contractor's expense, with corrective methods subject to the approval of the Construction Architect/Engineer.

END OF SECTION

DSWD-FOX

DIVISION 4 MASONRY

SECTION 4.01 CONCRETE MASONRY UNIT WORK

PART 1 GENERAL

1.1 SCOPE. This section includes concrete masonry unit work, complete.

1.2 DELIVERY, HANDLING, AND STORAGE OF MATERIALS. Cement and other cementitious materials shall be delivered to the site and stored in unbroken bags, barrels, or other approved containers, plainly marked and labeled with the manufacturer's names and brands. Mortar materials shall be stored in dry, weather tight sheds or enclosures, and shall be stored and handled in a manner which will prevent the inclusion of foreign material and damage by water or dampness. Concrete masonry units shall be handled with care to avoid chipping and breakage, and shall be stored as directed. Materials stored in newly constructed floors shall be stacked in such manner that the uniformly distributed loading does not exceed 50 psi. Concrete masonry materials shall be protected from contact with the earth and exposure to the weather, and shall be kept dry until used.

PART 2 MATERIALS

2.1 CONCRETE MASONRY UNITS shall be 2 or 3-core steam-cured modular blocks. Exterior and interior masonry units shall be load bearing and non-load bearing units with compressive strength of 800 psi and 400 psi respectively. However, load-bearing units may be provided in lieu of non-load-bearing units. Surfaces of units that are to be plastered shall be sufficiently rough to provide a suitable bond.

2.2 PORTLAND CEMENT shall be type 1 conforming to PNS 07.

2.3 SAND shall conform to PNS 18 type 1.

2.4 WATER for mixing shall be potable.

2.5 REINFORCING STEEL BARS shall be corrugated structural grade.

PART 3 PROPORTIONS, MEASUREMENT AND MIXING

3.1 MORTAR MIXING. Mortar materials shall be measured by volumetric proportioning in approved containers that will insure that the specified proportions of materials will be controlled and accurately maintained during the progress of the work. Measuring materials with shovels will not be

permitted. Unless specified otherwise, mortar shall be mixed in such a manner that the materials will be distributed uniformly throughout the mass. A sufficient amount of water shall be added gradually and the mass further mixed not less than 3 minutes until a mortar of the plasticity necessary for the purposes intended is obtained. Mortar boxes, pans and/or mixer drums shall be kept clean and free of debris of dried mortar. The mortar shall be used before the initial setting of the cement has taken place; re-tempering of mortar in which cement has started to set will not be permitted. Mortar shall be mixed in the proportions of one part Portland cement and 3 parts sand.

3.2 GROUT shall consist of a mixture of cementitious materials aggregate as specified hereinafter; water shall be added in sufficient quantity to produce a fluid mixture. Fine grout shall be provided in grout spaces less than 50 mm in any horizontal dimension or in which clearance between reinforcing and masonry is less than 20 mm. Coarse grout shall be provided in-group spaces 50 mm or greater in all horizontal dimensions and clearance between reinforcement and masonry is not less than 20 mm.

3.3 FINE GROUT shall be mixed in proportions of one part Portland cement and 3 parts sand.

3.4 COARSE GROUT shall be mixed in proportions of one part Portland cement, 3 parts sand and 3 parts pea gravel passing a 10-mm sieve.

PART 4 ERECTION

4.1 WORKMANSHIP. Concrete masonry walls shall be carried up level and plumb all around. One section of the walls shall not be carried up in advance of the others unless specifically approved. Unfinished work shall be stepped back for joining with new work. Heights of masonry at each floor, and at sills and heads of opening shall be checked with an instrument to maintain the level of the walls. Door and window frames, louvered openings, anchors, pipes, ducts and conduits shall be built-in carefully and in a neat manner as the masonry work progresses. Spaces around metal doorframes shall be filled solidly with mortar. Concrete masonry units shall be handled with care to avoid chipping, backing, and spilling of faces and edges. Structural steel work, bolts, anchors, inserts, plugs, ties, lintels, and miscellaneous metal work specified elsewhere shall be placed in position as the work progresses. Unless directed otherwise, partitions shall extend from the floor to the bottom of the floor or roof construction above. Non-load-bearing partitions and interior walls shall be securely anchored to the construction above in a manner that provides lateral stability while permitting unrestricted deflection of construction above, scaffolding well-braced and securely tied in position. Overloading of scaffolding will not be permitted.

4.2 MORTAR JOINTS shall be uniform in thickness, and the average thickness of any three consecutive joints shall be 10 mm to 12 mm. Changes in

coursing or bonding after the work is started will not be permitted. Exposed joints shall be rolled slightly concave with a round or other approved jointer when the mortar is thumbprint hard. The jointer shall be slightly larger than the width of the joint so that complete contact is made along the edges of the units, compressing and sealing the surface of the joint. Joints in masonry that will not be exposed shall be struck-flush. Horizontal joints shall be struck-flush. Horizontal joints shall be rolled first. Joints shall be brushed to remove all loose and excess mortar. All horizontal joints shall be level; vertical joints shall be plumb and in alignment from top to bottom of wall, within a tolerance of plus or minus 12 mm.

- 4.3 **CONCRETE MASONRY UNIT WORK.** The first course of concrete masonry units shall be laid in a full bed of mortar for the full width of the unit; the succeeding courses shall be laid with broken joints. The bed-joints of concrete masonry unit shall be formed by applying the mortar to the entire top surfaces of the inner and outer face shell. The head joints shall be formed by applying the mortar for a width of about 25-mm to the ends of the adjoining units laid previously. The mortar for joints shall be smooth, not furrowed, and shall be of such thickness that it will be forced out of the joints as the units are being placed in positions. Where anchors, bolts, and ties occur within the cells of the units, such cells shall be filled with mortar or grout as the work progresses. Concrete masonry units shall not be damped before or during laying.
- 4.4 **REINFORCING** shall be positioned accurately as indicated. As masonry work progresses, vertical reinforcing shall be rigidly secured in place at vertical intervals as indicated. Reinforcing shall be embedded in grout as grouting proceeds. The minimum clear distance between masonry and vertical reinforcement shall be not less than 12 mm. Unless indicated or specified otherwise, splices shall be formed by lapping bars not less than 20 bar diameters and wire tying them together.
- 4.5 **BONDING AND ANCHORING.** Masonry walls and partitions shall be accurately anchored or bonded at points where they intersect, and where they abut or adjoin the concrete frame of a building. All anchors shall be completely embedded in mortar.
- 4.6 **GROUT PLACEMENT.** Grouting shall be performed from interior side of walls, except as approved otherwise. Sills, ledges, offsets and other surfaces to be left exposed shall be protected from grout droppings; grout falling on such surfaces shall be removed immediately. Grout shall be stirred before placing to avoid segregation of the aggregate and shall be sufficiently fluid to flow into joints and around reinforcing without leaving voids. Grout shall be placed by pumping or pouring from buckets equipped with spouts, not exceeding 1.22 m; pours shall be kept at 38 mm below the top of masonry units in top course. Grout shall be puddled or agitated thoroughly to eliminate voids without displacing masonry from its original position.

Masonry displaced by grouting operation shall be removed and laid in re-alignment with fresh mortar.

END OF SECTION

DSWD-FOX

DIVISION 5.0 METAL

SECTION 5.01 METALS

PART 1.0 GENERAL

1.1 DESCRIPTION: The contents of this section apply to all sections of this division unless otherwise specified or modified.

1.2 REFERENCE STANDARDS: Comply with the latest edition of the following of the following as applicable unless otherwise specified or modified:

- A. AMERICAN INSTITUTE OF STEEL CONSTRUCTION (AISC), 1978: Specification for the Design, Fabrication and Erection of Structural Steel for Building; Code of Standard Practice for Steel Buildings and Bridges: Specification for Architecturally Exposed Structural Steel.
- B. AMERICAN IRON AND STEEL INSTITUTE (AISI): "Specifications for the Design of Cold Formed Steel Structural Members, 1974.'
- C. AMERICAN WELDING SOCIETY (AWS): Standard Welding Symbols A2.0-68; Standard Welding Code D1.1-1973 (Rev. 1-73 & 2-74). (To govern if in conflict with AISC).
- D. RESEARCH COUNCIL ON RIVETED AND BOLTED JOINTS OF THE ENGINEERING FOUNDATION (RCRBJ): Specification for Structural Joists using ASTM A-325-76a Bolts.
- E. STEEL JOIST INSTITUTE-AMERICAN INSTITUTE OF STEEL CONSTRUCTION (SJI-AISC): 'Standard Specifications for Open Web Steel Joists,' and 'Standard Specifications for Long span Steel Joists,' 1978 Editions.
- F. STRUCTURAL STEEL PAINTING COUNCIL (SSPC): Painting Manual, Volume 1; Good Painting Practice, Painting Manual, Volume 2; Systems and Specifications.

1.3 SOURCE QUALITY CONTROL

The Contractor shall be responsible for the fabrication, correct fitting and alignment of the various metal items or component members. However, the Fabricator shall permit the Architect or an independent inspection agency, if engaged by the Owner, to inspect work In progress in his shop. Such Inspection

shall not relieve the Contractor of his responsibility to furnish materials and workmanship in accordance with the Contract Documents.

1.4 PRODUCT DELIVERY, HANDLING AND STORAGE:

All materials shall be handled and stored in such manner as to prevent damage or disfigurement. Finished items or components shall be stored above ground on platforms, pallets, or other supports and protected from harmful elements.

1.5 PROTECTION:

The installer shall protect any existing work subject to damage during the installation of specified work and shall adequately protect specified work during installation. The installer shall protect finished work that is readily subject to damage by subsequent work or environmental conditions immediately following the installation thereof.

1.6 FIELD MEASUREMENTS:

Fabricator shall take actual measurements in field to verify or supplement dimensions indicated. He shall be responsible for accurate fit of specified work.

1.7 FIELD QUALITY CONTROL:

Facilities shall be provided by the Contractor, as needed, for the proper inspection of the specified work, including temporary platforms, hoists, protective devices, electric current, etc. Improper workmanship, as determined by the Architect, shall be corrected and replaced, at no additional cost to the Owner,

1.8 CONDITIONS OF WORK-IN-PLACE:

Work-in-place, on which specified work is in any way dependent, must be examined. Any defect that may influence satisfactory completion and performance of specified work must be reported, in writing, to the Contractor and the Architect. The absence of such notification shall be construed as acceptance of work-in-place.

1.9 CORROSION PROTECTION:

Separate dissimilar metals, and metals from soil and other corrosive surfaces, with a 30-mil coating of Bituminous compound, SSPC Paint 12, unless permanent separation is provided.

END OF SECTION

DIVISION 5.0 Metals

SECTION 5.02: Metal Materials and Methods

PART 1.0 GENERAL

1.1 **WORK INCLUDED:** The contents of this section are Inclusive of all metals used for this project with their corresponding methods of fabrication and Installation.

1.2 **REFERENCE STANDARD:** Refer to Section 5.01- Metals.

PART 2.0 PRODUCTS

2.1 MATERIALS

A. **CAST IRON:** Lowest grade acceptable for cast Iron shall be that of BS 321) Grade C. The casting shall be sharp and of exact form and required shape to fit the parts truly and to hold full dimensions. The product must be free from air holes, scratches, core nails, flaws and defects of any kind.

B. **WROUGHT IRON:** Shall be kept free from any crack, blister, flaw and any defect and comply with BS 51, Grade A.

C. **COPPER:** Shall conform to BS 743 and shall not be used in contact with aluminum.

D. **BRONZE:** Shall consist of 56.5% copper, 41.25% zinc) 2.25% lead and shall have a natural polished finish.

E. **BRASS:** Shall conform to any of the three main groups:

- Alpha brass 0-39 % zinc
- Alpha plus beta brass 39-46%
- Beta brass 46-50%

F. **STAINLESS STEEL SHEET:** Shall be of high chromium, high nickel steel. It shall comply generally with the requirements of BS 970 EN and be the type established for welding (58B).

G. **ALUMINUM SECTIONS OF FITTINGS:** Shall be anodized of a minimum

thickness 0.02mm of natural color or of analok finish as specified. All screws shall be stainless steel or approved alloy, countersunk flush whenever possible.

- H. STEEL: Shall be cold-rolled of high tensile strength with good surface finish. Provide tubular steel rafters for all structures. Refer to Structural Plans.
- J. METAL DOOR JAMBS: Shall be of pressed bend prefabricated type, gauge 16, shop painted with metal primer upon delivery to site. Refer to schedule for locations
- K. GALVANIZED STEEL: Shall be entirely and evenly coated with zinc and free from stains, bare spots and other defects, such as blisters, pits, unplated areas, cloudy patches, cracks and stains

PART 3.0

EXECUTION

3.1 INSTALLATION OF FITTINGS AND FIXTURES

- A. Floor gratings shall be provided for trench drains where needed or as indicated in the Plans. Stainless steel shall be used for trench drains located at lab and kitchen areas. Steel floor gratings shall be used for car parks, workshop / automotive areas and where Indicated in the plans. A 25mm recessed space shall be provided at each side of trench drain. Refer to Plans for the length of trench drains.
- B. Material dividers shall be provided at juncture of differences in flooring material, unless otherwise specified. Brass dividers, stainless steel strips, aluminum reducers shall be used, or as indicated In Interior Plans.

END OF SECTION

DIVISION 5 METALS

SECTION 5.03 STRUCTURAL STEEL WORK

PART 1 GENERAL

- 1.1 SCOPE. This section includes structural steel work, complete.
- 1.2 HANDLING, SHIPPING AND STORING OF MATERIALS. All materials shall be handled, shipped, and stored in a manner that will prevent distortion or other damage. Materials shall be stored in a clean location and keep properly drained. All damaged materials shall be replaced or repaired by and at the expense of the contractor.

PART 2 MATERIALS

- 2.1 STRUCTURAL CARBON STEEL FOR BOLTED OR WELDED WORK shall conform to ASTM A36.
- 2.2 STRUCTURAL TUBING FOR BOLTED OR WELDED WORK shall conform to ASTM A500 or A501.
- 2.3 BOLTS AND NUTS shall conform to the requirements for regular hexagon bolts and nuts of ANSI 818.2.1 and 818.2.2. Materials shall conform to ASTM 307.
- 2.4 WASHERS. Circular washers shall be flat and smooth and shall conform to requirements for Type A washers in ANSI B 27.2. Beveled washers to American Standard Beams and channel shall be square or rectangular, shall conform tapered in thickness, and shall be smoothed. Washer for use- with high strength bolts shall be hardened.
- 2.5 WELDING ELECTRODES AND RODS.
- 2.6 SUBMERGED ARC WELDING. Bare electrodes and flux for submerged arc welding shall conform to the requirements of AWS D1.0, and the following grades:

STEEL	GRADE
A36	SAW-1 or SAW-2

PART 3

FABRICATION

- 3.1 **GENERAL.** Except as modified herein, fabrication shall be in accordance with the applicable specifications and standards of the American Institute of Steel Construction. Workmanship shall be equal to standard commercial practice in modern structural shops. Portions of the work exposed to view shall be finished neatly.
- Structural materials, either plain or fabricated, shall be stored above the ground on platforms, skits, or other supports. Material shall be kept from dirt, grease, and other foreign matter, and shall be protected as far as practicable from corrosion. All materials shall be clean and straight. If straightening or flattening is necessary, it shall be done by a process and in a manner that will not damage the material. Shearing, flame-cutting and chipping shall be done carefully and accurately. The radii of a re-entrant gas-cut fillet shall be not less than 25 mm and as large as practicable. The top and bottom surfaces of base plates, cap plates of columns and sole plates shall be planed, or the plates shall be hot straightened and parts of members in contact with them shall be faces.
- 3.2 **BOLTED CONSTRUCTION.** Holes for bolted construction shall be 1.59 mm larger than the nominal diameter of the bolt. Holes shall be clean cut without torn or ragged edges. Outside burrs resulting from reaming or drilling shall be removed. For punched holes the diameter of the die shall not exceed the diameter of the punch by more than 1.59 mm. The dies for sub-punched holes shall be at least 1.59 mm smaller than the nominal diameter of the bolt. If any hole must be enlarged to admit the bolts, they shall be reamed. Reamed holes shall be cylindrical and perpendicular to the member. Where practicable, reamers shall be directed by mechanical means. After assembly of the member and before reaming, holes punched full size and holes sub-punched shall admit a cylindrical pin 3 mm less in diameter than the nominal size of the holes perpendicular to the face of the member without drifting in not less than 75 percent of any group of continuous holes in the same plane. When holes are reamed or drilled, 85 percent of the holes in any contiguous group, after reaming or drilling, shall show no offset greater than 79 mm between adjacent thickness of metal. Bolts' holes shall be at right angle to the member. The slope of bolted parts in contact with the bolt head shall not exceed 1:20 with respect to a plane normal to the bolt axis. Where the surface of a bolted path has slope of more than 1:20, beveled washer shall be used to compensate for the lack of parallelism.
- 3.3 **STRUCTURE'S SUBJECT TO STATIC LOADING.** Holes for bolts shall be drilled or sub-punched and reamed, except that where the thickness of the material is not greater than the nominal diameter of the bolt plus 3 mm, the holes may be punched full size.

- 3.4 COMMON BOLTS. Bolts transmitting shear shall be threaded to such a length that not more than one thread would be within the grip of the metal. The bolts shall be of such length that they will extend entirely through the nuts with the beveled end outside the nut. Bolt heads and nuts shall be drawn tight against the work with a suitable wrench not less than 38-cm long. Bolt heads shall be tapped with a hammer while the nut is being tightened.
- 3.5 SHOP PAINTING. All structural steel work, except zinc coated surfaces and steelwork to be embedded in concrete or mortar, shall be shop painted. Surfaces to be welded shall not be coated within 75 mm of the weld, prior to welding. Surfaces shall be thoroughly dry and clean when the paint is applied. No painting shall be done in wet weather except under cover; the temperature shall be above 45 degrees F. but not over 90 degrees F. Paint shall be applied thoroughly. Surfaces that will be concealed or inaccessible after assembly shall be painted prior to assembly.

PART 4 PREPARATIONS PRIOR TO ERECTION

- 4.1 CLEANING. Except as modified herein, surfaces shall be cleaned to bare metal by a suitable blasting process. Surfaces that may be damaged by blasting shall be cleaned to bare metal by powered wire brushing or other mechanical means. Surface that will be enclosed from the weather and subject to exposure no more corrosive than an indoor atmosphere controlled for human comfort, may be cleaned by wire brushing or other manual or mechanical means for removal of loose mill scale, rust, dirt, and other deleterious substances. Cleaned surfaces, which become contaminated with rust, dirt, oil, grease, or other contaminants, shall be washed with solvents until thoroughly clean. Steel to be embedded in concrete shall be free from dirt and grease. Bearing surfaces, including contact surfaces within friction-type joints, shall not be painted nor galvanized but shall be coated with rust preventive coating, applied in the shop. The coating shall be removed just prior to field erection using a remover approved by the rust preventive manufacturer. The surfaces, when assembled, shall be free from rust, greases. Dirt and other foreign matter.
- 4.2 PRE-TREATMENT. Except as modified herein, immediately after cleaning, surfaces shall be coated with a coat of pre-treatment coating applied to a dry film thickness of 0.3 to 0.5 mil or be given a crystalline phosphate base coating. The phosphate base coating shall be applied only to blast-cleaned bare metal surfaces.
- 4.3 PRIMING. Treated surfaces shall be primed as soon as practicable after the pre-treatment coating has dried. Except as modified herein, the primer shall be two coats of epoxy type or as specified in Section: Field Painting applied to a minimum dry film thickness of 3 mils. Surfaces that will be concealed after construction and will require no over-painting may be primed.

Damage to primed surfaces shall be repaired with primer.

- 4.4 MATCH MARKING. Members and component part of structures shall be assembled and match marked prior to erection to insure accurate assembly and adjustment of position on final erection. Painted assembly markings shall be removed from any surface to be welded or riveted. Scratch or notch marks shall be located in a manner that will not affect the strength of the member or cause concentrations of stress.

PART 5 ERECTION

- 5.1 GENERAL. Except as modified herein, erection shall be in accordance with the applicable specifications and standards of the AISC "Manual of Steel Construction". Erecting equipment shall be suitable for the work and shall be in first class condition. Where parts cannot be assembled or fitted properly because of errors in fabrication or of deformation due to handling or transportation, such condition shall be reported immediately to the Construction Architect/Engineer and his approval of the method correction obtained. The correction shall be made in his presence. Bent or damaged parts shall be rejected. Steelwork shall be drained properly. Pockets in structures exposed to the weather shall be filled with waterproof material. Safety belts and lines shall be used by workers on high structures, unless safe working platforms or safety nets are provided.
- 5.2 ASSEMBLY. The frame of steel structures shall be carried up true as shown and all match markings shall be followed. Temporary bracing shall be used wherever necessary to support all loads to which the structure may be subjected, including equipment and operation thereof and piles of materials. Such bracing shall be left in a place as long as may be required for safety. The various members forming parts of a completed frame after being assembled shall be aligned and adjusted accurately before being fastened. Fastening of splices of compression members shall be done after the abutting surfaces have been brought completely into contact. No riveting, welding, or bolting shall be done until much of the structure will be stiffened and by has been aligned properly. Bearing surfaces and surfaces which will be in permanent contact shall be cleaned before the members are assembled. As erection progresses, the work shall be bolted or welded sufficiently to take care of all dead load, wind, and erection stresses. Splices will be permitted only where indicated. Erection bolts used in welded construction may be tightened securely and left in place; if removed, the holes shall be filled with plug welds.
- 5.3 FIELD BOLTING shall be in accordance with the requirements specified for shop fabrication. Unfair holes shall be corrected by reaming.

5.4 FIELD WELDING shall be as specified for shop fabrication of welded construction. Any shop paint on surfaces adjacent to joints to be field-welded shall be wire-brushed to reduce the paint film to a minimum.

5.5 FIELD PAINTING. All exposed surface of steelwork shall be shop painted. Surfaces where the shop coat of paint has been damaged shall be retouched using the same system as the original shop painting. Surfaces which will be in contact after erection, except when in contact with bolted or welded connections, and shall be given one finish coat before erection. The cleaning, pre-treatment and priming of welds and the areas adjacent thereto shall be done promptly after the acceptance of the weld and shall be as specified under the shop painting.

PART 6 INSPECTION

6.1 GENERAL. Contractor's inspection shall be made promptly to permit immediate correction of defects. The inspector shall stamp each piece, which is accepted, with the mark assigned to him. The contractor shall be fully responsible for the accuracy and character of the work in all details, errors or faults which are discovered after delivery or during erection shall be corrected by the contractor in accordance with the requirements of the contract and without increase in the contract price. The contractor shall provide competent supervision and visual inspection of all fabrication through shop inspectors whose primary duty is inspection.

END OF SECTION

DIVISION 6.0 WOOD AND PLASTICS

SECTION 6.01 CARPENTRY

PART 1.0 GENERAL

1.1 **WORK INCLUDED.** This section covers the furnishing of all materials, labor, equipment, and everything listed or mentioned on the drawings and necessary in performing all operations for the completion of all finish carpentry works in accordance with all applicable drawings and subject to the terms and conditions of the contract.

1.2 **QUALITY ASSURANCE**

A. QUALIFICATION OF WORKMEN

If required by the Architect, the Manufacturer of specified work shall show evidence of his experience, including a list of projects for which he manufactured work similar in scope and quality to the specified work.

In the acceptance or rejection of finish carpentry, no allowance will be made for lack of skill on the part of the workmen.

For actual cutting and fitting of trim and finish materials, use only competent finish carpenters, who have been thoroughly trained and experienced in the skills required, who are completely familiar with the materials Involved and the manufacturers' recommended methods of installation, and who are thoroughly familiar with the requirements of this work.

B. REJECTION

In the acceptance or rejection of finish carpentry, no allowance will be made for lack of skill on the part of the workmen.

1.3 **PRODUCT HANDLING**

A. PROTECTION

All means necessary must be utilized to protect the material of this section before, during, and after installation and to protect the installed work and materials of all other trades. All finish materials must be stored at 12-inch minimum above the floor.

B. REPLACEMENT

In the event of damage, all necessary repairs and replacements must be immediately made, subject to the approval of the Architect and at no additional cost to the Owner.

1.4 CONDITIONS OF WORK-IN-PLACE

A. INSPECTION

1. Prior to all work covered in this Section, the installed work of all other trades must be carefully inspect to verify that all such work is completed to the point where this installation may properly commence.
2. Verify that finish carpentry may be completed in strict accordance with the original design and all pertinent Codes and Regulations.

B. DISCREPANCIES

1. In the event of discrepancies, immediately notify the Architect.
2. Do not proceed with the installation in areas of discrepancy until all such discrepancies have been fully resolved.

1.5 SUBMITTALS

- A. SHOP DRAWINGS: Show materials, layouts, details of construction, dimensions and, where necessary, installation details.
- B. SAMPLES: Panels, plastic laminates, moldings, trims.
- C. CERTIFICATES: Manufacturer's Certificate of Compliance

PART 2.0 PRODUCTS

2.1 MATERIALS

A. FINISH WOOD AND WOOD FRAMES

1. All finish wood shall be of quality suitable for painting finish specified and shall be fire retardant treated. Exterior finish wood shall also be water-repellent treated.

2. Lumber shall be of the best grade available of the respective kinds required for the various parts of the work, well-seasoned, thoroughly dry, and free from loose or unsound knots, cup shakes or other imperfections impairing its strength, durability or appearance. All exposed surfaces shall be smooth unless otherwise specified.
3. Yakal, Guijo or Paitan shall be used for wood plates, doorjambs, head, stair framing, girders, girt, and for all wood works in contact with masonry and all exposed woodworks where Indicated on schedule.
4. Pressure treated Apitong or Tanguile shall be used for ceiling joists, studs, cleats, roof framing, rafters, bottom chords and nailers and all other woodworks for structural purposes.
5. Narra or Tanguile, kiln dried, shall be used for baseboards, cornices, door casings, and other moldings, wood framing, paneling, cabinetry and all other woodworks specified in the drawings to be Narra or Tanguile.
6. Plywood shall be A-B grade 6 mm, 12 mm, 19 mm thick, and fire resistant treated with Fire Hazard Classification Rating of not more than 25 for flame spread, fuel-contributed and smoke-generated. Use marine plywood for exposed, use ordinary plywood for painted paneling and ceiling requirements and ribbon grain, Tanguile for varnished paneling and doors.

B. SPECIALTIES

- 3 1. BASEBOARDS & MOULDINGS: Narra or Tanguile, kiln dried, with size and finishes as indicated in architecture plans.
2. MAIN STAIR HANDRAIL AND TREADS; Yakal or Guijo wood in stained finish with wrought iron supports as approved by the Architect. Refer to Plans for details.

C. TREATMENT

All wood used for finishing shall be kiln-dried with fire retardant, unless otherwise specified. All exposed wood shall be kiln-dried to be applied with approved type of wood preservative, Xyladecor or equal.

D. MISCELLANEOUS

- G. 1. ROUGH HARDWARE: Rough hardware shall be provide for all Items such as spikes, nails, bolts, toggle bolts, anchor bolts, wood screws, straps, clips necessary for the installation of specified work. Rough hardware items shall be of suitable type and of sufficient size and length to draw the work

firmly together. Anchor bolts for wood nailers shall be steel 1/2-inch diameter. All rough hardware shall be hot-dip galvanized.

2. CABINET HARDWARE: All necessary cabinet hardware shall be provided. (See notes on Hardware Schedule and refer to architectural plans.)

PART 3.0

EXECUTION

3.1

CONDITIONS OF WORK-IN-PLACE

A. Work-in-place, on which specified work is in any way dependent, must first be carefully examined. Any defect, which may influence satisfactory completion and performance of specified work, must be report, in writing, to the Architect

B. The absence of such notification shall be construed as acceptance of work-in-place.

C. Architectural woodwork, and other finished woodwork, shall be installed only when normal temperature and humidity conditions approximate the interior conditions that will exist when the building is occupied. The building should not be cold and damp, or hot and dry.

3.2

FABRICATION

A. Construction millwork to meet or exceed "Quality Standards ", for custom grade for exposed surfaces.

B. Finished work shall be square, plumb and true, and free from defects and blemishes.

C. When it is necessary to cut and fit work at job site, units and materials shall be made with ample allowance for cutting.

D. All joints shall be formed and made, both in shop and at job site, in such manner as to securely join members together and prevent warping, splitting and opening up of joined parts due to swelling and shrinkage.

E. Whenever possible, fastening shall be concealed on surfaces exposed to view. Where not possible, secure with finishing nails or screws and glue; set all nail heads, and countersink all screw heads and cover with neatly fitted wood plugs to match grain. Fasten exterior work with non-corrosive fasteners.

3.3

INSTALLATION

A. Install trim in as long lengths as possible, with tight joints, coped where

possible.

- B. Secure work with finishing nails or screw and waterproofing glue, on surfaces exposed to view, set all nail heads, and countersink all screw heads and cover with neatly fitted wood plugs to match grain.
- C. Apply exterior materials with non-corrosive devices as detailed and as required to complete the project.

3.4 FINISHING HARDWARE

- A. Install all hardware listed in FINISH HARDWARE SECTION or required in completing the project.
- B. Adjust moving parts to operate properly.

END OF SECTION

DSWD-FOX

DIVISION 7.0

THERMAL & MOISTURE PROTECTION

SECTION 7.01

INTEGRAL TYPE WATERPROOFING (CAPILLARY)

PART 1.0 GENERAL

1.1 **WORK INCLUDED:** This section deals with waterproofing and surface treatment of concrete structures, as shown on the drawings and as specified herein, with special reference to enclosures due to contain liquids of a quality sufficient to create hydrostatic pressure. This includes the roof slab, concrete gutters, plant boxes, elevated walkways and all areas indicated in the plans.

1.2 **QUALITY ASSURANCE:**

A. **QUALIFICATION OF INSTALLER:** At least one person, who is thoroughly experienced in the installation of the specified products, must be present at all times during execution of this portion of the work. He shall direct all work performed under this Section.

B. **MANUFACTURER'S CERTIFICATION:** Prior to the installation of the work of this Section, a representative of the manufacturer of the waterproofing materials used shall visit the job site in order to inspect and to certify;

1. That the surfaces to which the waterproofing was applied were in condition suitable for that application;
2. That the materials installed complied in all respects with the requirement of this Section of the specifications;
3. That the materials were installed in complete accordance with the manufacturers' current recommendations.

1.3 **PRODUCT HANDLING:**

A. **PROTECTION:** Safety measures must be utilized to protect waterproofing materials before, during, and after installation and to protect the installed work and materials of all other trades.

B. **REPLACEMENTS:** In the event of damage, necessary repairs and replacements must be made, subject to the approval of the Architect and at no additional cost to the Owner.

PART 2.0 PRODUCTS

2.1 MATERIALS

- 4 A. Waterproofing materials needed for this system shall be cementitious powder, consisting of 38 active chemicals, wherein crystals are formed once in contact with water. These crystals will follow the water through 15 Inches of solid concrete structure, thus filling the voids and capillary tracts with their crystalline, resulting in the prevention of seepage of water in the area while still allowing the substrate to breathe. Use (PRODUCT) as distributed by Man's Work Trading or approved equal.
- 5 B. The waterproofing effect is produced by the active chemicals in the (PRODUCT) coating that reacts with the free lime of the concrete, hence, producing a non-soluble crystal. The crystallization process in the capillaries produces a barrier from water and thus (PRODUCT) becomes an integral part of the structure. (PRODUCT) is effective in any direction of water or osmotic pressure, which means it may be applied to either Internal or external surface. However, wherever possible, it is preferable to apply (PRODUCT) to the surface with which water is in direct contact. This will create an accelerated rate of penetration and crystallization into the concrete structure.

PART 3.0 EXECUTION

3.1 SURFACE PREPARATION:

- 6 A. All concrete must be structurally sound. All forms of scale, oil, form release agents, laitance, and any foreign materials, which will impair the bond, penetration, and performance of the (PRODUCT) waterproofing must be removed. Employ acid etching, water pressure blasting or light sand blasting, if necessary. Rout visible cracks exceeding 0.01" in size $3/4$ " deep, also honeycomb pockets and faulty construction joints. Form tie holes shall be left approximately 1" back of surface. Rinse all surfaces thoroughly with water the day prior to the application. All surfaces to receive integral (capillary) waterproofing shall be poured to slope to drain to avoid additional concrete for leveling screed.
- B. Moisture must be present in the concrete strata to assure maximum chemical penetration. Surfaces shall be moist only, not wet when (PRODUCT) coating is applied.

3.2 MIXING

7 A. GENERAL: (PRODUCT) is mixed in a proportion of 2 parts (PRODUCT) to 1 part water by volume. Always add water to the (PRODUCT) and never on the reverse order. However, a mixture of 1 part (PRODUCT) to 1 part water is recommended for concrete surfaces that is too rough but an additional coat is added to attain the same material usage rate of 1.0 to 1.5 kg. per square meter for 2 to 3 coats.

B. RATE OF USE: As a general rule, it may be considered that for a two-coat slurry application, the rate of use of (PRODUCT) should be between 0.5 kg. and 0.75 per square meter per coat.

3.3 CURING

8 A. Moisture cure HYGARD treated surfaces for a period of three days starting with fine water fog spraying the day following the completion of (PRODUCT) application. Backfill material can be placed on (PRODUCT)

B. All (PRODUCT) treated surfaces to receive Epoxy coating or To be aged for a minimum period of two weeks before application of Epoxy.

3.4 GUARANTEE

(MANUFACTURER'S NAME) shall supply, install, and guarantee the works specified in this section, free from defects of materials, workmanship and leakage for five years from the date of final acceptance.

END OF SECTION

DIVISION 7.0

THERMAL AND MOISTURE PROTECTION

5 SECTION 7.02 Caulking and Sealants

PART 1.0 GENERAL

1.1 QUALIFICATIONS

- A. Before specified material or system is installed, the manufacturer or his authorized agent shall inform the Architect, in writing, that he has familiarized himself with the Contract Document, environmental conditions, and intended occupancy for this specific project and that his material or system is appropriate to the conditions to be encountered therein.
- B. Before specified material or system is installed, the manufacturer shall inform the Contractor, in writing, that he is familiar with the quality of workmanship of the installer and approves him as the installer of his material or system for this specific project

1.2 A. BROCHURES: Submit Caulking and Sealant Manufacturer's Instructions for Application and Priming.

B. SAMPLES: Samples shall be submitted to the Architect, upon request.

- 1. Cured sealant after color selection has been made from the Manufacturers Color Range Brochure.
- 2. Filler back-up material for sealant
- 3. Caulking material after color selection has been made from the Manufacturers Color Range Brochure.

1.3 PRODUCT DELIVERY, HANDLING AND STORAGE

A. Deliver materials to the project site with manufacturers label intact and legible. Where materials are factory-packaged, same shall be delivered In the original sealed containers.

B. Specific item and/or its components shall be handled in such manner as to prevent damage or deformation. Same shall be properly protected from harmful elements or damage by other work prior to its Incorporation into the project

C. Materials shall be stored as per the manufacturers' recommendations. Materials with expired shelf life shall not be used.

1.4 PROTECTION OF EXISTING WORK

- A. Adjacent work shall be protected against damage by specified work.
- B. Work adjacent to joints shall be cleaned free of smears of caulking or sealant compound as work progresses. Surfaces difficult to clean shall be protected with masking tape.
- C. Finished work that is readily subject to damage by subsequent work or, environmental conditions shall be protected by the installer immediately following the installation thereof.
- D. Damaged work, as determined by the Architect, shall be repaired or replaced to the Architects satisfaction.

1.5 WARRANTY

- A. All caulking and sealant work shall be warranted, in writing, against all defects of materials and application for a period of five (5) years after date of acceptance.
- B. Any failure that may occur within this period due to defective materials and/or application shall, upon written notice of same, be repaired or replaced with proper materials and/or labor, as approved by the Architect and at no additional cost to the Owner.

1.6 FIELD QUALITY CONTROL

- A. Facilities shall be provided by the Contractor as needed for the proper inspection of specified work by the Manufacturer and the Architect.
- B. Improper workmanship or selection of materials, as determined by the Manufacturer or the Architect, shall be corrected and/or replaced at no additional cost to the Owner.

1.7 CONDITIONS OF WORK-IN-PLACE

Work-in-place, on which specified work is in any way dependent, shall be examined. Any defect, which may influence satisfactory completion and performance of specified work shall be report, in writing, to the Architect. The absence of such notification shall be construed as acceptance of work-in-place.

PART 2.0 PRODUCTS

2.1 CAULKING MATERIALS

- A. CAULKING: Vegetable oil and/or resin base, gun grade, elastic compound, conforming to FS TT-C-598B, Type I, color as selected by Architect from the manufacturers Standard Color Range. Dow Coming or Euxit 950.
- B. PRIMER FOR POROUS SURFACES: Non-staining product of Caulking Manufacturer for use when recommended and as specified for the application by the manufacturer.
- C. JOINT BACKING: Back-up material to have outside diameter at least thirty (30%) percent greater than joint width and shall be one of the following: Oakum, picked dry and free of oil and tar; closed-cell Neoprene, tubular or rod stock; or Polyethylene rod stock.

2.2 SEALANT MATERIALS

- A. SEALANT for building construction perimeter joints such as windows, doors, panels, expansion joints, control joints, coping, etc., shall be a two-component non-staining elastomeric sealing compound based on liquid Polysulfide Polymer. Dow Coming or Euxit 950.
- B. COLOR: To be selected by the Architect from the Manufacturers Standard or Custom Color Range matching color of adjacent materials as closely as possible.
- C. PRIMER: Non-staining product of Sealant Manufacturer.
- D. JOINT BACKING: Closed-cell Neoprene or polyethylene Rod E-wa foam with square cross section. Width of materials shall be thirty (30%) percent greater than joint width.
- E. BOND-BREAKER TAPE: Wrinkled or smooth faced masking tape or other adhesive faced tape product is adaptable to installation in the bottom of a solid-backed joint for the purpose of breaking bond between the sealant and back of joint
- F. PRE-FORMED COMPRESIBLE JOINT FILLER (For other than Poured-in-Place concrete):
Non-Extruding and Non-Bituminous Type, ASTM D1752, Type I or II.

PART 3.0 EXECUTION

3.1 LOCATION

- A. Caulking compound shall be installed in interior joints, including joints around pipes, conduits and ducts, which penetrate interior walls and partitions and all other locations so indicated in the drawings.
- B. Sealant compound shall be installed in the following locations:
 - 1. All exterior joints where air, water, or sound could penetrate.
 - 2. Control and expansion joints in interior or exterior masonry.
 - 3. All other locations indicated to be sealed.

3.2 APPLICATION: General

- A. Do not apply exterior sealant in damp or rainy weather or until surfaces have thoroughly dried from the effects of such weather.
- B. Install specified material only after preparatory work has been approved and when adjoining work is in proper condition to receive it. Apply to masonry joints before they have been treated with a water-repellant or masonry preservative.

3.3 JOINT PREPARATION

- A. GENERAL: All joint surfaces must be dry, thoroughly clean, and free from grease, oil, wax, lacquer, paint or other foreign matter. At Contractors option, sealant filler back-up material may be placed in exterior joint flush with exposed surfaces to avoid early contamination of joint prior to proper scheduling for sealing of joint and as a temporary weather seal. When sealing of joint takes place, the filler shall be recessed into the joint to the proper depth as herein specified. Any damaged back up material shall be replaced prior to sealing.
- B. MASONRY, CONCRETE OR OTHER POROUS SURFACES: Remove all loose particles, dirt, paint, foreign matter, or curing compound by sandblasting or other approved means and prime. Exposed fine aggregate of concrete surfaces to be sealed.
- C. METAL OR OTHER SMOOTH SURFACES: Remove corrosion by wire brush or chemical cleaners of other approved method. Wipe surface with clean cloth soaked in solvent, such as Toluol or Metyl-Ethyl-Kethone or other approved solvent, and then wipe surface dry with clean, dry cloth while surface still wet with solvent.

D. PRIMING: Joint interfaces, to which caulking and sealant compounds are applied, shall be primed when recommended by the Compound Manufacturer. Primers shall be applied in strict accordance with the Caulking or Sealant Manufacturers latest printed instructions and shall be allowed to cure before installation of caulking or sealant compound

3.4 JOINT DIMENSION

A. GENERAL: Install backing, of type and size specified, at proper depth in joint to provide specified joint dimension. Caulking or sealant compound shall not be applied without backing. Install bond-breaking tape where back-up is a solid material. Tubular or rod stock backing shall be rolled into the joint to avoid lengthwise stretching and shall not be twisted or braided.

B. CAULKING JOINTS: Depth of caulking compound shall be from 1 to 2 times joint width. Joint width shall be not less than 1/4-inch nor more than 3/4 inch.

C. SEALANT JOINTS: No sealant contacting surfaces shall be less than 1/4-inch. Sealant shall be 1/4-inch deep for 1/4-inch wide joints, 3/8-inch deep for 3/8-inch to 1/2-inch wide joints, and 1/2-inch deep for 1/2-Inch to 1-Inch wide joints, unless indicated otherwise by the manufacturer.

3.5 INSTALLATION

A. Installation shall be performed in strict accordance with the Manufacturers latest printed instructions. Caulking or sealant compound shall be forced into opening with hand or air-powered caulking gun and tooled so as to fill void completely. Gun shall have nozzle of proper size to fit joint.

B. Take care not to smear adjoining surfaces with caulking or sealant compound. Finish exposed butt joint surfaces slightly concave by tooling unless otherwise indicated or directed by the Architect.

C. Sealant shall not be allowed to remain on exposed face of surfaces.

3.6 REPAIR OF DEFECTIVE WORK

A. Restore all defective or damaged work to initial condition. Defective or damaged items and/or components, which cannot be repaired or restored to initial condition, shall be removed and replaced at no additional cost to the Owner.

3.7 CLEANING

- A. At the end of each day, installer shall remove from the project site all accumulated trash generated by his work.
- B. Upon completion of specified work, thoroughly clean all surfaces of sealing materials, masking tape, etc.

END OF SECTION

DSWD-FOX

DIVISION 7.0 THERMAL AND MOISTURE PROTECTION

SECTION 7.04 Metal Roofing

PART 1.0 GENERAL

- 1.1 **DESCRIPTION:** The metal roofing required for this work is indicated on the drawings.
- 1.2 **QUALITY ASSURANCE:** Work shall be done by thoroughly trained and experienced workmen, who are completely familiar with the materials involved and the recommended methods of installation.
- 1.3 **PRODUCT HANDLING**
- A. PROTECTION:** The Roofing Contractor shall use all means necessary to protect the materials before, during and after installation. All roofing materials shall be stored in a covered shelter or covered completely with loose tarpaulin or similar materials and stock with one end slightly elevated.
- B. REPLACEMENTS:** In the event of damage, all necessary repairs and replacements must be immediately made, subject to the approval of the Architect and at no additional cost to the Owner.
- 1.4 **SUBMITTALS:** Samples of finishes and accessories, shop drawings showing materials, layouts, details of construction, installation and all necessary dimensions shall be submitted.

PART 2.0 PRODUCTS

- 2.1 **MATERIALS:** All metal roofing shall be horizontal Rib Design Pre-painted metal roofing, 5MM THK METAL ROOF – (DURATHERM ROOF).
- 2.2 **THICKNESS:** 0.4mm to 0.6mm thick, (Ga. 26) Color-roof sheets for roofing and 0.4mm thick. (GA. 26) for flashing. *Use Ga. 24 stainless steel gutters.*
- 2.3 **COLOR:** For Architects approval.
- 2.4 **FASTENING:** Fastened by metal cleats, which are mounted on the roof structure by means of self-drilling screws, wood screws or stove bolts. Location

of fasteners are along trusses and rafters.

- 2.5 ACCESSORIES: Provide all accessories indicated in the drawings or necessary for the completion of work. *Use Individual hip and ridge caps.*

PART 3.0 EXECUTION

3.1 ROOF FRAMING

- A. Roof frames should be well anchored.
- B. Rafters and trusses should be straight, level and parallel to each other.
- C. Regular spacing between rafters and trusses should be based on metal thickness and profile of roof to be installed.
- D. Provide top girt along ridge line and bridging at midspan between rafters along valley gutter line.
- E. Double rafters should be provided with 0.10 meter (4') clear space between rafters along valley gutter line.
- F. Gutters should be installed before any roofing is laid.

3.2 ROOF INSTALLATION

- A. Roof framing should be well anchored, straight, level and parallel to each other.
- B. Check that all gutter and eave lines are perpendicular by using the 345 triangle method or by Intersecting method.
- C. Install the main gutter before the hip and valley gutters.

3.3 ROOF CARE DURING INSTALLATION

- A. Cement from concreting works, waterproofing compounds, chemical solutions, joint welding sparks, nails and iron tools should not be allowed to drop on, extend to or rust away at the roof, since removal or scraping of such materials later could damage the roof's coating.
- B. Scaffoldings should have protective caps on the points of contact with the roof and should be rested gently on the roof edges, gutters and end-flashings to prevent dents and scratches.

C. Roof traffic should be minimized. When crossing the roof area, walking should be conducted along roof frame locations, along overlaps or on wooden planks laid over the roof panels.

3.4 CLEANING UP

A. Pick up all discarded scrap materials, especially ferrous metals such as nails and wires.

B. Immediately wash all plastering sites with water.

C. Clean all gutters of leaves and other waste refuse to prevent clogging at downspout areas and to allow the continuous flow of water.

3.1 FRAMING AND BRACING

A. Frames and supports should be well anchored.

B. All Bracing and sun louvers shall be straight, level and parallel to each other.

C. Regular spacing between sun louvers should be based on metal thickness and profile specified in the drawings.

3.3 SUN LOUVER CARE DURING INSTALLATION

A. Cement from concreting works, waterproofing compounds, chemical solutions, joint welding sparks, nails and iron tools should not be allowed to drop on, extend to or rust away at the roof since removal or scraping of such materials later could damage the sun louvers coating.

B. Scaffoldings should have protective caps on the points of contact with the sun louvers and should be rested gently on the walls to prevent dents and scratches.

3.4 CLEANING UP

A. Pick up all discarded scrap materials, especially ferrous metals such as nails and wires.

B. Immediately, wash all plastering sites with water.

C. To attain its original bright cluster finish, wipe the panel with the wet rag and follow it up with a clean, dry rag.

END OF SECTION

DIVISION 7 THERMAL AND MOISTURE PROTECTION

SECTION 7.06 FIBER-CEMENT BOARDS

PART 1.0 GENERAL

1.1 **WORK INCLUDED:** This section covers the furnishing of all materials, labor, and equipment, necessary in performing all operations for the Fascia Board subject to the terms and conditions of the Contract.

1.2 **QUALITY ASSURANCE**

Specified work shall be done by thoroughly trained and experienced workmen who are completely familiar with the materials involved and the manufacturer's recommended methods of installation.

1.3 **PRODUCT HANDLING**

A. **PROTECTION:** The Contractor shall use all means necessary to protect the materials before, during and after installation. Sheets should generally stacked on edge or laid flat on a smooth level surface. Edges and corners should be protected from chipping. To ensure optimum performance, store sheets under cover and keep dry prior to fixing. If the sheet should become wet, allow to dry thoroughly before fixing is commenced.

B. **REPLACEMENTS.** In the event of damage, immediately make all repairs and replacements necessary to the approval of the Architect at no additional cost to the Owner.

1.4 **SUBMITTALS**

A. **SHOP DRAWINGS / MANUFACTURER'S BROCHURE:** Show materials, layouts, details of construction, installation and all necessary dimensions. Submit manufacturer's latest manual for installation.

B. **SAMPLES:** Fiber-cement boards, vertical metal studs, fasteners & accessories.

PART 2.0 PRODUCTS

2.1 **MATERIALS:** Use HARDIFLEX Flat Sheets as distributed by Man's Work Trading. Refer to plans for exact location and design of the fiber-cement boards.

A. **HARDIFLEX** is a smooth surfaced fiber-cement building sheet that will not rot and burn. It can be finished with two coats of water-based acrylic or PVA paints. **HARDIFLEX** shall not be used as a backing sheet for textured coating.

- a. Thickness: Use 6mm thick for ceiling, as indicated in the plans.
- b. Dimensions: 2400 x 1200mm

B. **HARDIPANEL COMPRESSED** is a high density autoclaved double faced fiber-cement building sheet that does not contain asbestos. The sheets are light-gray in color and have square edges suitable for expressed jointing. Hardipanel Compressed sheet for the Fascia Board shall be 18mm thick or as indicated on the plans.

2.2 **ACCESSORIES:** Provide corner and flashing moulds, PVC Hardijointer, gauge 16 galvanized metal framing and all necessary accessories to complete the work. Sample of all accessories shall be submitted for Architect's approval.

2.3 **FASTENERS:** Provide Galvanized fiber-cement nails for timber construction and galvanized screws for metal-framed construction. Refer to Manufacturer's recommended type of fasteners.

PART 3.0 EXECUTION

3.1 **FRAMING:** Framing shall be constructed in accordance with local building regulations and acceptable building practice. Studs, timber or light-gauge metal should be spaced at 450 or 600mm on centers. Ceiling joist shall be spaced at 400mm x 600mm on centers

3.2 FIXING

A. **HARDIFLEX Panels:** Fix to metal frames with 19mm galvanized screws. Space screws no further than 300mm apart in center of sheets, 200mm around edges and no less than 12mm from the edge of sheets. Screws in ceiling sheets should be spaced at 250mm on center of sheet. Screws may be driven flush with sheet surface.

Fasten sheets to furring battens fixed vertically at 600mm max. centers and nogged horizontally at 1200mm max. centers.

B. **HARDIPANEL Compressed:** Fixing of top hat sections to structural subframing to engineer's details. Subframing including girts/studs etc. shall be in accordance with the Engineer's/ Architect's details. The Hardipanel Compressed fascia system can accommodate some misalignment in the locations of the subframing by using neoprene packers or approved equivalent between the top hats and the subframing. In light of this, the

installed positional tolerances for the subframing as outlined in the relevant project specification should be checked so that a sensible amount of packing is expected. Fasten sheets to furring battens fixed at 600mm vertically & horizontally.

- C. Verify Manufacturer's Brochures for detailed information on applications and installations.

3.2 GUARANTEE

Deliver to the Architect and Owner a guarantee signed by Man's Work Trading guaranteeing all materials to be free from defects and deterioration for a period of at least (No. of years). Likewise, the installation firm shall issue the Owner a guarantee against damage and defects for all cladding works for a period of (No. of Years) minimum following date of application.

END OF SECTION

DSWD-FOX

DIVISION 7 THERMAL AND MOISTURE PROTECTION

SECTION 7.07 SKYLIGHT

PART 1.0 GENERAL

1.1 **DESCRIPTION:** The work includes polycarbonate and tinted, tempered and sandblasted glass skylight roofing systems, complete.

1.2 **DELIVERY AND STORAGE:** Skylight glazing shall be carefully handled to avoid breaking and scratching. Polycarbonate and glass skylights showing cracks, chips, or other defacements will be rejected. It shall be stored in dry weather-tight sheds or enclosures, and shall be stored and handled in a manner which will prevent the inclusion of foreign material.

PART 2.0 PRODUCTS

2.1 **TRELLIS SKYLIGHT:** Shall be 10mm thick, tinted polycarbonate sheets in Bronze Anodized (Analok) Aluminum frames on Pre-cast RC Trellis in smooth plaster, as approved by Architect.

2.2 **CANOPY SKYLIGHT:** Shall be 12mm thick, tinted, tempered and sandblasted glass in Bronze Anodized (Analok), and on Steel Girt w/ Cladding Aluminum frames, as approved by Architect.

PART 3.0 EXECUTION

3.1 **CLEARANCES:** Edge clearance shall not be less than 3mm for steel frames. The minimum edge clearance shall not be less than the thickness of the polycarbonate sheet. The face clearance of the polycarbonate from rabbets or stops shall not be less than 3mm.

3.2 **SKYLIGHT ROOFING SYSTEM:** Skylight roofing system shall be provided as indicated with metal framing (Rohm Universal connecting set) secured to the roofing system by concealed anchors and stainless steel bolts and screws. Provide horizontal and vertical studs in between the skylight frames as may be required to ensure a heavy-duty installation. Provide sealing materials as specified herein before for a water tight installation.

3.3 **INSTALLATION:** Gutter, roof insulation, and roof tiles should be installed before installing the skylight.

3.4 **WORKMANSHIP:** All works shall be performed in accordance with the best practices of the trade for a watertight installation. Defective plastic and glass skylight glazing damaged during construction shall be replaced by the Contractor at no additional cost to the Owner.

- 3.4 SUBMITTAL: Submit brochures, samples, and installation procedures of the plastic and glass skylight roofing and sealant intended to be used for the project prior to procurement.

END OF SECTION

DSWD-FOX

DIVISION 8.0 DOORS, WINDOWS & GLASS

SECTION 8.01 STEEL DOORS AND FRAMES

PART 1.0 GENERAL

1.1 DESCRIPTION

A. INCLUDED: All items and components forming any portion of the Steel Doors and Frames, including louvers, glass stops, hardware provisions, etc., all work to install same in place.

B. RELATED WORK DESCRIBED ELSEWHERE

6

- 7 I. Furnishing Finish Hardware : Section 08700
- 2. Finish Painting : Section 09900

1.2 SUBMITTALS

A. SHOP DRAWINGS: Within 35 days after awarding of contract, and before any metal doors and frames are delivered to the job site, submit shop drawings, brochures, and Installation instructions to the Architect for review in accordance with the provisions of these specifications. Clearly show detail of each frame type, elevations of each door type, conditions of openings with various wall thickness and materials, typical and special details of door construction, method of assembling sections; location, reinforcement and Installation requirements for hardware; size, shape, and thickness of materials.

B. SCHEDULES: Submit door and frame schedule relating type of door and frame to be installed in each opening.

C. BROCHURES: Submit 12 corner sample showing construction and finish.

PART 2.0 PRODUCTS

2.1 PRODUCTS

A. METAL FLUSH DOOR: Covering for doors shall be heavy duty mild steel, Ga. 18 with a 2 hour fire rating & filled with fiberglass insulation. Standard duty frames shall be mild steel Ga.16 tubular framing, unless indicated otherwise. Frames shall be bonderized and prime finish painted. Refer to plans for location and design of metal doors.

B. **HARDWARE PREPARATIONS:** All necessary hardware in this section shall be provided for and installed by skilled workmen in accordance to manufacturer's recommendations.

2.2 FABRICATION OF METAL FLUSH DOORS

A. **TYPE:** Flush type with no visible seams.

B. **MANUFACTURE:** Construct to required shape and profile by forming and welding, with straight edges, corner, hairline joints and surfaces free from warp, wave buckle or other defects. Exposed welding beads shall be grind and flush finished. Door edges shall have vertical seams filled with mineral filler and finished flush.

C. **CORES:** Comply with one of the following.

1. Minimum 18-gauge Interlocking steel channels or zees spot welded to inner surfaces of outer sheets, minimum four (4) vertical and eight (8) horizontal. Fill spaces between core members with sound deadening liner.
2. The voids between stiffeners shall be filled with fiberglass insulation.

D. **TOP FILLER CHANNELS:** Provide 18-gauge integral filler channels to close top of the exterior doors if not already closed in basic construction.

E. **HARDWARE PREPARATION:** Factory mortise, reinforce, drill and tap in accordance with templates or physical hardware furnished by Finished Hardware Supplier. Provide minimum 3/16-inch reinforcement for hinges, 14-gauge for locksets, and 12-gauge for surface applied hardware.

F. **CLEARANCE OF METAL FLUSH DOORS:** Provide 1/8-Inch clearance between door and frame at head and lock jamb, 1/16-inch at hinge jamb with square edge doors (3/32 with beveled edge), 3/8-inch to finish floor (*114-inch* above top of carpets), and 1/4-inch to top of threshold unless noted otherwise.

G. **LOUVERS:** Louvers for doors shall be of sizes indicated, built into door, sightproof stationary type, with "Z" blades with spacing as indicated on the drawings, and formed from mild steel, standard ga. 16, Door manufacturer's standard louver may be employed subject to the approval of the Architect.

2.3 SHOP PAINTING

A. Apply primed finish to all ferrous metal surfaces furnished under this Section.

B. Remove all oil, grease, sand, dirt or other foreign substance. After cleaning,

chemically treat metal surfaces to assure maximum paint adherence. After cleaning, follow with dip or spray coat of rust inhibitive metallic oxide, zinc-chromate or synthetic resin metal primer on all exposed surfaces, baked-on or oven-dried. Finish surfaces shall be smooth and free from irregularities and rough spots.

PART 3.0 EXECUTION

3.1 INSTALLATION OF METAL FLUSH DOORS

A. CONCRETE WALLS: Install frames in forms plumb and to true planes, securely anchoring in-place prior to placing concrete. Provide welded anchors and horizontal stiffeners to prevent jambs from bowing.

B. MASONRY WALLS: Erect in position, plumb and securely anchor to floor and brace. Install horizontal spreaders to keep jambs from bowing and fill solid with grout and mortar.

3.2 INSULATION OF DOORS: Install accurately in respective frames, maintaining specified clearances.

END OF SECTION

DIVISION 8.0 DOORS AND WINDOWS

SECTION 8.02 ALUMINUM DOORS AND FRAMES

PART 1.0 GENERAL

1.1 APPLICABLE PUBLICATIONS:

The publications listed below for a part of this specification to the extent referenced. The publications are referred to in the text by the basic designation only.

A. FEDERAL SPECIFICATION (FED. SPEC.):

TT-P-645A Primer, paint, zinc Chromate, Alkyd Type

B. MILITARY SPECIFICATION (MIL.SPEC.):

MIL-C-18480B Coating Compound, Bituminous, Solvent, Coal Tar Base

C. AMERICAN SOCIETY FOR TESTING AND MATERIALS (ASTM) PUBLICATIONS:

- A 36-81 Structural Steel
- B. 209-82 Aluminum and Aluminum Alloy and Plate (Rev. B)
- B. 221-82 Aluminum-alloy Extruded Bar, Rod, Wire, Shape (Rev. B) and tube

D. ALUMINUM ASSOCIATION (AA) PUBLICATION:

1980 Designation System for Aluminum Finishes

E. ARCHITECTURAL ALUMINUM MANUFACTURING ASSOCIATION (MMA) PUBLICATIONS:

603.8-1980 Performance Requirements and Test Procedures for Pigmented Organic Coatings on Extruded Aluminum

605.2-1980 High Performance Organic Coatings on Architectural Extrusions and Panels

1.2 SUBMITTALS:

A. SHOP DRAWINGS: Include the following:

1. Elevation of each door type

2. Size of doors and frames
 3. Metal gauges
 4. Details of door and frame construction
 5. Methods of anchorage
 6. Glazing details
 7. Weather stripping
 8. Provisions for and location of hardware
 9. Hardware specifications
 10. Details of installation
 11. Schedule showing location of each door, frame, and swing of door
- B. SAMPLES: Samples shall be submitted in duplicate, unless otherwise specified. Metal samples shall be complete with required color and finish.
1. Corner section of door and frame members showing method of joining, glazing methods, weather-stripping, and facing sheets, not less than 7' x 7' in overall size.
 2. Each color and finish specified for aluminum, 4' x 4' in size. For each color-anodized finish, show the extremes of the color range.
- C. MANUFACTURER'S DESCRIPTIVE LITERATURE: Detail specifications and instructions for Installation, adjustments, cleaning, and maintenance.
- D. CERTIFICATES OF COMPLIANCE: Manufacturers certificates attesting that doors, frames, and accessories meet the specified requirements.

1.3 DELIVERY, STORAGE, AND PROTECTION

- A. All materials delivered to the site shall be inspected for damage.
- B. All materials shall be unloaded and stored with minimum handling. The storage space provided shall be in a dry location with adequate ventilation, free from dust or water, and easily accessible for inspection and handling. Materials shall be stored neatly on the floor, properly stacked on non-absorptive strips of platforms, and handled in such a manner as to protect them from damage during the construction period.
- C. Do not cover doors and frames with tarps, polyethylene film or similar coverings.

- D. Protect finished surfaces during shipping and handling using manufacturers standard method, except no coatings or lacquers shall be applied to surfaces to which caulking and glazing compounds must adhere.

PART 2.0 PRODUCTS

2.1 DOORS AND FRAMES

Sliding type aluminum doors and frames of size, design, and location Indicated. Provide doors complete with frames, framing members, adjoining sidelights and accessories.

2.2 MATERIALS

- A. ANCHORS: Steel with hot-dipped galvanized finish.
- B. WEATHER STRIPPING: Neoprene or rubber gasket silicone treated, or type recommended by door manufacturer.
- C. ALUMINUM ALLOY FOR DOORS AND FRAMES: ASTM B 221, Alloy 6063-T% for extrusions. ASTM B 209, alloy and temper best suited for the purpose for aluminum sheets and strips.
- D. FASTENERS: Hard aluminum or stainless steel.
- E. STRUCTURAL: ASTM A 36.
- F. ZINC-CHROME: Fed. Spec. TT-P-645.
- G. BITUMINOUS PAINT: Mil. Spec. MIL-C-18480.

2.3 FABRICATION

- A. ALUMINUM FRAMES: Extruded aluminum shape to contours approximately as indicated. Minimum wall thickness for frames: 0.125 Inch, or 0.09 inch with reinforcing ribs. Minimum wall thickness for glazing beads, molding and trim: 0.050 Inch. Provide removable glass stops and glazing beads for frames accommodating fixed glass. Countersunk mild steel Philips head screws shall be used for the exposed fastenings, and space not more than 12 Inches on center. Mill joint in frame members to a hairline watertight fit, reinforce, and either weld along concealed lines of contact or secure mechanically. Shapes shown are representations of design, function, and required profile, and function maybe used subject to Architect's approval.
- B. ALUMINUM DOORS: Of type, sizes, and design indicated and not less than 1-3/4 inches thick. Minimum wail thickness: 0.125 inch, except beads and trims, 0.050 inch. Door sizes shown are nominal and shall include standard clearances as follows: 1/16 inch at hinges tiles, 1/16 or 1/ 8 at lock stiles and top rails, and 3/16 inch at floors and thresholds. Double-acting doors shall

have square edges at hinge stile, lock stile, and meeting stile edges. Full Glazed Stile and Rail Doors: Doors shall have stile and rails, as indicated. Fasten top and bottom rail together by means of welding 3/8 or 1/2-Inch diameter cadmium-plated tensioned steel tie rods. An adjustable mechanism of jack screws or other methods shall be provided in the top rail to allow for minor clearances adjustments after installation.

- C. WELDING AND FASTENING: Where possible, locate welds on unexposed surfaces. Welds on exposed surfaces shall be smoothly dressed. Select welding rods, filler wire, and flux to produce a uniform texture and color in finished work. Removed flux and spatter from the surfaces immediately after welding. Exposed screws or bolts will be permitted only at inconspicuous locations, and shall have countersunk heads. Concealed reinforcements for hardware in place shall be welded.
- D. WEATHER-STRIPPING: Provide on stiles and rails of exterior doors. Fit into slots which are Integral with doors or frames. Weather-stripping shall be easy to replace without special tools, and adjustable at meeting rails of pairs of doors. Installation shall allow doors to swing freely and close positively.
- E. ANCHORS: Anchors, of the sizes indicated, shall be provided on the back of sub-frames for securing sub-frames to adjacent construction. Transom bars shall be anchored at ends and mullions at head and sill. Free standing door frames shall be reinforced and anchored to floor construction, as indicated on approved shop drawings and in accordance with manufacturers' recommendation. Anchors shall be placed as near top and bottom of each jamb and at intermediate points not more than 25 inches apart.
- F. PROVISIONS FOR HARDWARE: Hardware shall be manufacturer-supplied. Specifications and samples shall be submitted for approval. Hardware templates and hardware, except field-applied hardware, shall be delivered to the door manufacturer for use in fabrication of aluminum doors and frames.
Cut, reinforce, drill, and tap doors and frames at the factory to receive template hardware. Doors shall be provided to receive surface-applied hardware, drill and tap in the field. Provide hardware reinforcements of stainless steel or steel with hot-dipped galvanized finish, and secure welding or stainless steel screws.
- G. PROVISIONS FOR GLAZING: Extruded aluminum snap-in glazing beads shall be provided on interior side of doors. Extruded aluminum, theft-proof, and snap-in glazing beads or fixed glazing beads shall be provided on exterior or security side of doors. Glazing beads shall have vinyl insert glazing

gaskets, neoprene or rubber gaskets. Glazing beads should be designed to receive glass of thickness indicated or specified. Glazing is specified in the Section 08810, GLASS AND GLAZING.

H. FINISHES: Exposed aluminum surfaces shall be factory finished with bronze anodized coating, 20 microns thick.

Anodic Coating: Clean exposed aluminum surfaces and profile an anodized finish conforming to AA 'Designation system for Aluminum Finishes.' The Anodic coating shall be 0.002 cm thick minimum for all external and internal surfaces.

PART 3.0 EXECUTION

3.1 INSTALLATION

A. METHOD OF INSTALLATION: Frames and framing members shall be plumbed, squared, leveled, and aligned to receive doors adjoining sidelights. Frames shall be anchored to adjacent construction as Indicated and in accordance with manufacturers' printed instructions. Bottom of each frame shall be anchored to rough floor construction; mild steel angle clips secured to back of floor construction; mild steel bolts and expansion rivets used for fastening clip anchors. Metal-to-metal joints between framing membranes shall be sealed as specified as in Section 07920, SEALANT AND CAULKING. Hang doors accurately with proper clearances and hardware. After erection and glazing adjust hardware to operate properly.

1. Masonry and Concrete: Provide aluminum surfaces in contact with mortar, concrete, or other masonry materials with one coat of heavy-bodied bituminous paint.

2. Wood or Other Absorptive Materials: Provide aluminum surfaces in contact with absorptive materials subject to frequent moisture, and aluminum surfaces in contact with treated wood with two coats of aluminum paint or one coat of heavy-bodied bituminous paint In lieu of painting the aluminum, the Contractor shall have the option of painting the wood or other absorptive surfaces with two coats of aluminum paint and sealing the joints with caulking compound.

B. PROTECTION: Protect doors and frames from damage. Prior to completion and acceptance of the work, restore damage doors and frames to original condition, or replace with new.

C. CLEANING: Upon completion of installation, thoroughly clean door

and frame surface in accordance with door manufacturers recommended procedure. Do not use abrasive, caustic, or acid cleaning agents.

END OF SECTION

DSWD-FOX

DIVISION 8.0 DOORS AND WINDOWS

SECTION 8.03 WOOD DOORS

PART 1.0 GENERAL

1.1 SUBMITTALS

A. **SHOP DRAWINGS:** Indicate dimensions and elevation of each door type, location in building of each door, and pertinent erection instructions.

B. **SAMPLES:** Submit samples of corner section of each type of door cut diagonally with twelve-inch sides, showing construction and finish.

1.2 PRODUCT HANDLING

Specified work shall be protected against damage and dampness during transportation to project site. Damaged items shall be replaced without additional cost to the Owner. Specified work shall be delivered to the building, in which it is to be installed and at such time when the normal temperature and humidity conditions approximate the interior conditions that will exist when the building is occupied.

1.3 WARRANTY

Specified work shall be guaranteed for two (2) years starting from date of Owners acceptance against warping, twisting or manufacturing defects. During the "Warranty Period", the contractor, shall ascertain that each wood door shall be equal in quality to the original specifications; the contractor shall make the necessary adjustments without additional cost to the Owner, including all labor costs of handling and refinishing. The Contractor further agrees to make the replacement within ten (10) days after the receipt of notice from the Owner.

PART 2.0 PRODUCTS

2.1 FLUSH HOLLOW CORE DOOR

A. **TANGUILE DOOR:** 45 mm thick door using 6 mm thick Tanguile plywood veneer applied on horizontal cross-banding. For flush doors of Comfort Rooms and other moisture exposed doors, use 6mm thick fiber cement board facing.

B. **FACE:** 3 plywood veneer, verify type from plans

C. **STILE EDGES:** Provide stile edges to doors as shown on the drawings.

D. TOP AND BOTTOM EDGES: Hardwood or soft wood in accordance with the MANUFACTURER'S latest printed standards. Top and bottom edges of doors shall be sealed with spar varnish or other approved sealer prior to shipment

E. FRAME: Provide wood frames trimmed from 50 x 50 mm wood strips. Use thoroughly seasoned, kiln dried soft wood cores for frames and trim, milled true to form from solid stock and free from defects that would impair its strength or durability. Provide applied members at jambs and heads where indicated.

Provide applied members at jambs and heads where indicated.

2.2 PANEL DOORS

TANGUILE OR NARRA: Panel doors shall be decorative or carving-type, from Tanguile or Narra, as indicated.

2.3 SLIDING DOORS

Sliding doors shall be from Tanguile, kiln-dried frames with 6 mm. Tanguile plywood veneer.

PART 3.0 EXECUTION

A. WOOD DOORS: Wood doors shall be conditioned to the average prevailing temperature and humidity at building before hanging. Doors should fit accurately in their respective frames, with proper door clearances.

B. CLEARANCES: Door clearances shall be 1/8-Inch at head and lock stile, 1/6-inch at hinge stile, and 1/2-inch at bottom including thickness of resilient floor covering, unless otherwise indicated.

C. CONSTRUCTION: Stiles and rails shall be mortised and provided with the necessary rabbets to receive the specified type of panel. All joints shall be made with water resistant glue. The assembled door frames shall be held in retainers until the glue has dried and attained its strength.

Panels shall be true to shape and profiles and shall be uniform throughout for doors of the same type. Mouldings shall be solid with sharp and clean cut profiles. All joints at corners shall be mitered.

D. FINISH: Upon completion of each door unit, the door shall be sanded free

of machine marks, which will show through the finish. Verify from Plans for the finish of all doors.

END OF SECTION

DSWD-FOX

DIVISION 8 DOORS AND WINDOWS

SECTION 8.04 POLYVINYL CHLORIDE (PVC) DOORS AND WINDOWS

PART 1 GENERAL

- 1.1 SCOPE. This section covers PVC doors, windows and frames, complete.
- 1.2 QUALITY ASSURANCE. All PVC doors, windows and frames shall conform to the best commercial standard.
- 1.3 STORAGE AND PROTECTION. PVC doors windows and frames shall be handled in such a manner as to protect against damage. Doors shall be stored in a covered and well-ventilated building, where they will not be exposed to extreme changes in humidity.
- 1.4 SUBMITTAL REQUIREMENTS. Prior to fabrication and delivery, doors, windows and frames catalog cuts and sample finishes shall be submitted for Architect's approval.

PART 2 PRODUCTS AND MATERIALS

- 2.1 DOOR AND WINDOW FRAMES. Frames shall be of the design and size indicated. Frames shall be set plumb, true, and braced to prevent distortion. Frames in masonry or concrete walls shall be bolted or as indicated. Frames shall be PVC, manufactured by POLYDOOR Industrial Sales, with good grade hardwood as stiffener inside for hinges.
- 2.2 DOORS AND WINDOWS. Doors and windows shall be POLYDOOR moulded PVC door, manufactured by POLYDOOR Industrial Sales, and shall be factory pre-fabricated. Color and configuration shall be as approved by the Architect.

PART 3 INSTALLATION

Hinged doors shall be hung plumb, and fitted accurately. Allow 1.59 mm clearance at the jambs and heads. Lock stiles of doors, 44 mm thick or thicker, shall be leveled 3 mm in 50 mm. Knob locks and latches shall be installed 97 cm from finished floors to the center knobs. Hardware shall be applied with fastenings of the size, quality, quantity and finish to provide a workable door system. Windows shall be hung plumb, and fitted accurately and provided with appropriate hardware as approved.

END OF SECTION

DIVISION 8.0 DOORS AND WINDOWS

SECTION 8.05 ALUMINUM WINDOWS AND FRAMES

PART 1.0 GENERAL

1.1 **DESCRIPTION:** All Items and components forming any portion of the Aluminum Windows and Frames including hardware provisions, glass and glazing, etc., and all similar work to install in the place.

1.2 **QUALIFICATIONS:**

- A. Before specified material or system is installed, the manufacturer, or his authorized agent, shall inform the architect, in writing, that he has familiarized himself with the Contract Documents, environmental conditions, and intended occupancy for this specific project and that his material or system is appropriate to the conditions to be encountered therein,
- B. Before specified material or system is installed, the manufacturer shall inform the Architect, in writing, that he is familiar with the quality of workmanship of the installer and approve of him as the installer of the material or system for this project

1.3 **SUBMITTALS**

- A. **SHOP DRAWINGS:** Submit shop drawings, brochures and installation instructions. Clearly show detail of each frame type, elevations of each window frame type, conditions of openings with various wall thickness and materials, typical and special details of window frame construction, method of assembling sections, location reinforcement and Installation requirements for hardware: size, shape, and thickness of materials.
- B. **SCHEDULES:** Submit Window Schedule relating type of window and frame to be installed in each opening.
- C. **BROCHURE:** Manufacturers descriptive data indicating materials, construction section, finishing system, etc.
- D. **SAMPLE:** Submit 12” corner sample showing construction and finish.

1.4 **PROTECTION:**

- A. The Installer shall protect any existing work subject to damage during installation of specified work.

B. Finished work that is readily subject to damage by subsequent work or environmental conditions shall be protected by the installer immediately following the installation thereof.

C. Materials should be stored out of contact with the ground and shall be arranged in such a way as to avoid warping, bending, or damaging.

1.5 FIELD MEASUREMENT

Fabricator of custom work shall make measurements in the field to verify or supplement dimensions indicated and be responsible for accurate fit of specified work.

1.6 FIELD QUALITY CONTROL

A. Facilities needed for the proper inspection of specified work shall be provided by the Contractor.

B. Improper workmanship, as determined by the Architect, shall be corrected and replaced at no additional cost to the Owner.

1.7 CONDITION OF WORK IN- PLACE

Work-in-place on which specified work is in any way dependent shall be examined. Any defect, which may influence satisfactory completion and performance of specified work, shall be reported, in writing, to the Architect. The absence of such notification shall be construed as acceptance of work-in-place.

PART 2.0 PRODUCTS

2.1 MATERIALS

A. ALLOYS: Aluminum shall be of commercial quality and proper alloy for window construction, free from defects impairing strength and/or durability. Detached hardware and hinges having component parts (screws, nuts, washers, bolts, rivets, clips, etc.), which are exposed, shall be aluminum.

B. WEATHER-STRIPPING: All weather strips shall be of continuous vinyl with suitable profiles.

C. HARDWARE: Manufacturer-supplied. Submit specifications and samples for approval.

D. FRAMING: The framing members must be square and true and properly designed to resist any load they have to support. Any framing member

should not deflect more than 1 / 175 of its span, with a maximum of 30 mm at any point. The twisting of the horizontal bottom member should be limited to 1” from the horizontal plane. Glazing stop or any other fitting should be designed to resist any bad transmitted to the glazing.

- E. **REBATE:** The rebate must be dimensional, according to the glazing type, size, and tolerances and must accommodate the glazing materials. The rebate will be protected against corrosion. The sill member will have adequate weep. All types of rebates, channels, or structural gaskets must be provided with a weep system in order to: (a) prevent the accumulation of moisture in the rebate for prolonged periods; and (b) squeeze the moisture vapor pressure between the air outside and the air inside the rebate. There should be at least 2 weep holes situated in the bottom of the rebate, with additional ones every 50 cms. over 1 meter. They will be oblong-shaped, their smallest dimension will be 5 mm, their surface at least 50 sq. mm.

2.2 DIMENSIONAL TOLERANCES

TOLERANCES	DIMENSION	
3 mm. max.	inside width of frame	□
3 mm. max.	Inside depth of frame	□
2 mm. max.	Depth of frame	□
2 mm. max.	Diagonal distance	□

- 2.4 **SHOP COATING:** Prior to coating, all oil, grease, sand, dirt or other foreign substance must be removed. The anodic coating shall be 20 microns thick, bronze anodized finish for all surfaces. Finish surfaces shall be smooth and free from irregularities and rough spots.

2.5 PERFORMANCE SPECIFICATION

- A. **NOISE REDUCTION LEVEL:** All windows shall be designed and constructed to reduce exterior peak ambient, air borne noise levels not exceeding 45 decibels.
- B. **AIR TIGHTNESS:** Air Infiltration shall not exceed 0.184 cu.m. / sq.m. (0.06 cfm / sq.ft.) of window area. The permeability (Q/L) shall be less than 0.2 m / sq.m.h.
- C. **THERMAL INSULATION:** Heat transmission shall be less than $k = 3.0$ kilo calories / sq.m. hour °C.
- D. **WATER TIGHTNESS:** The window shall be watertight enough as to withstand 200 kg/ sq.m. water pressure.

E. UNIT STRENGTH: Aluminum finishing shall have electrolytic pigmentation of more than 18 microns.

F. FRAMING: The framing members must be square, true and properly designed to resist any load they will have to support. Any framing member should not deflect more than 1/175 of its span, with a maximum of 20 mm at any point the twisting of the horizontal bottom member should be limited to 1" from the horizontal plane. Glazing or any other fitting should be designed to resist any load transmitted by the glazing.

PART 3.0 EXECUTION

3.1 CONDITIONS PRIOR TO INSTALLATION: Provisions for drainage of any water leakage and condensation taking place within the construction must be made.

3.2 INSTALLATION OF FRAMES

A. CONCRETE WALLS: Install frames in forms, plumb and true to planes, securely anchoring in place, prior to placing concrete. Provide necessary anchors and horizontal stiffeners, if required, to prevent frames from bowing.

B. MASONRY WALLS. Erect in position, plumb and securely anchor to floor and brace horizontal spreaders and fill solid with grout and mortar.

3.3 REPAIR OF DEFECTIVE WORK

Restore all defective or damaged work to initial condition. Defective or damaged items and / or components which cannot be repaired or restored to initial condition shall be removed and replaced at no additional cost to the Owner.

3.4 CLEANING

Frame should be wiped with a soft cloth, sponge or brush and cleaned with a mild solution of detergent every 6 months. Harsh cleaning materials such as steel wool or abrasive scouring powders should be avoided and strong acid or alkali cleaners should not be used.

END OF SECTION

DIVISION 8 DOORS AND WINDOWS

SECTION 8.06 SPECIAL WINDOWS

PART 1.0 GENERAL

1.1 SCOPE: This section includes special types of windows like clerestory and transom windows in areas as indicated in plans.

1.2 QUALIFICATIONS:

- A. Before specified material or system is installed, the manufacturer, or his authorized agent, shall inform the architect, in writing, that he has familiarized himself with the Contract Documents, environmental conditions, and intended occupancy for this specific project and that his material or system is appropriate to the conditions to be encountered therein.
- B. Before specified material or system is installed, the manufacturer shall inform the Architect, in writing, that he is familiar with the quality of workmanship of the installer and approve of him as the installer of the material or system for this project.

1.3 SUBMITTALS

- A. SHOP DRAWINGS: Submit shop drawings, brochures and installation instructions. Clearly show detail of each frame type, elevations of each window frame type, conditions of openings with various wall thicknesses and materials, typical and special details of window frame construction, method of assembling sections, location reinforcement and installation requirements for hardware : size, shape, and thickness of materials.
- B. SCHEDULES: Submit Window Schedule relating type of window and frame to be installed in each opening.
- C. BROCHURE: Manufacturer's descriptive data indicating materials, construction section, finishing system, etc.
- D. SAMPLE: Submit 12" corner sample showing construction and finish.

1.4 PROTECTION:

- A. The installer shall protect any existing work subject to damage during installation of specified work.
- B. Finished work that is readily subject to damage by subsequent work or environmental conditions shall be protected by the installer immediately

following the installation thereof.

1.5 FIELD MEASUREMENT

Fabricator of custom work shall make measurements in the field to verify or supplement dimensions indicated and be responsible for accurate fit of specified work.

1.6 FIELD QUALITY CONTROL

A. Facilities shall be provided by the Contractor as needed for the proper inspection of specified work.

B. Improper workmanship, as determined by the Architect, shall be corrected and replaced at no additional cost to the Owner.

1.7 CONDITION OF WORK - IN- PLACE

Examine work-in-place on which specified work is in any way dependent. Report, in writing, to the Architect any defect which may influence satisfactory completion and performance of specified work. The absence of such notification shall be construed as acceptance of work-in-place.

PART 2.0 PRODUCTS

2.1 MATERIALS

A. ALLOYS: Aluminum shall be of commercial quality and proper alloy for window construction, free from defects impairing strength and / or durability. Detached hardware and hinges having component parts (screws, nuts, washers, bolts, rivets, clips, etc.) which are exposed shall be aluminum. ALUMINUM ALLOY FOR WINDOWS AND FRAMES: ASTM B 221, Alloy 6063-T% for extrusions. ASTM B 209, alloy and temper best suited for the purpose for aluminum sheets and strips.

B. STEEL: Steel shall be mild, heavy duty quality with a 2 hour fire rating and filled with fiberglass insulation for door construction; free from defects impairing strength and / or durability.

C. WEATHERSTRIPPING: All weather strips shall be of continuous vinyl with suitable profiles.

D. HARDWARE: Manufacturer-supplied. Submit specifications and samples for approval.

E. FRAMING: The framing members must be square and true and properly designed to resist any load they will have to support. Any framing member

should not deflect more than 1/ 175 of its span, with a maximum of 30 mm at any point. The twisting of the horizontal bottom member should be limited to 1" from the horizontal plane. Glazing stop or any other fitting should be designed to resist any load transmitted to the glazing. Windows and frames shall also be installed to resist typhoons.

- F. **REBATE:** The rebate must be dimensional according to the glazing type, size, and tolerances and to accommodate the glazing materials. The rebate will be protected against corrosion. The sill member will have adequate weep. All types of rebates, channels, or structural gaskets must be provided with a weep system in order to (a) prevent the accumulation of moisture in the rebate for prolonged periods ; (b) squeeze the moisture vapor pressure between the air outside and the air inside the rebate. Situated in the bottom of the rebate there should be at least 2 weep holes with additional ones every 50 cms. over 1 meter. They will be oblong shaped, their smallest dimension will be 5 mm, their surface at least 50 sq. mm.
- G. **ANCHORS:** Steel with hot-dipped galvanized finish.
- H. **FASTENERS:** Hard aluminum or stainless steel.
- I. **STRUCTURAL:** ASTM A 36.
- J. **ZINC-CHROME:** Fed. Spec. TT-P-645.
- K. **BITUMINOUS PAINT:** Mil. Spec. MIL-C-18480.

2.2 **DIMENSIONAL TOLERANCES**

DIMENSION	TOLERANCES
Inside width of frame	3mm max.
Inside depth of frame	3mm max.
Diagonal Distance	2mm max.
Depth of frame	2mm max.

2.3 **FINISHES FOR ALUMINUM FRAMED WINDOWS:** Exposed aluminum surfaces shall be factory applied with bronze anodized coating, 20microns thk. Anodic Coating: Clean exposed aluminum surfaces and profile an anodized finish conforming to AA “Designation system for Aluminum Finishes.” The Anodic coating shall be 0.002cm thk. minimum for all external and internal surfaces. This ‘analok’ frame shall be used for Clerestory Windows; Provide 6mm thk. Bronze-tinted glass on steel frames, analok color for Transom Windows.

FINISHES FOR STEEL FRAMED WINDOWS: Provide 6mm thk. Bronze-tinted glass on steel frames, primer and painting; analok color for Transom Windows.

2.4 PERFORMANCE SPECIFICATION

- A. **NOISE REDUCTION LEVEL:** All windows shall be designed and constructed to reduce exterior peak ambient, air borne noise levels not exceeding 45 decibels.
- B. **AIR TIGHTNESS:** Air infiltration shall not exceed 0.184 cu.m./sq.m. (0.06 cfm/sq.ft.) of window area. The permeability (Q/L) shall be less than 0.2 m/sq.m.h.
- C. **THERMAL INSULATION:** Heat transmission shall be less than $k=3.0$ kilocalories/ sq.m. hour $^{\circ}\text{C}$.
- D. **WATER TIGHTNESS:** The window shall be watertight enough as to withstand 200 kg/ sq.m. water pressure.
- E. **UNIT STRENGTH:** Aluminum finishings shall have electrolytic pigmentation of more than 18 microns.
- F. **FRAMING:** The framing members must be square true and properly designed to resist any load they will have to support. Any framing member should not deflect more than $1/175$ of its span, with a maximum of 20 mm at any point. The twisting of the horizontal bottom member should be limited to 1" from the horizontal plane. Glazing or any other fitting should be designed to resist any load transmitted by the glazing. Windows and frames shall also be installed to resist typhoons.

PART 3.0 EXECUTION

3.1 **CONDITIONS PRIOR TO INSTALLATION:** Make provisions for drainage of any water leakage and condensation taking place within the construction.

3.2 INSTALLATION OF FRAMES

- A. **CONCRETE WALLS:** Install frames in forms plumb and true to planes, securely anchoring in place prior to placing concrete. Provide necessary anchors and horizontal stiffeners, if required, to prevent frames from bowing.
- B. **MASONRY WALLS:** Erect in position, plumb and securely anchor to floor and brace horizontal spreaders and fill solid with grout and mortar.

3.3 REPAIR OF DEFECTIVE WORK

Restore all defective or damaged work to initial condition. Defective or

damaged items and / or components which cannot be repaired or restored to initial condition shall be removed and replaced at no additional cost to the Owner.

3.4 CLEANING

Frame should be wiped with a soft cloth, sponge or brush and cleaned with a mild solution of detergent every 6 months. Harsh cleaning materials such as steel wool or abrasive scouring powders should be avoided and strong acid or alkali cleaners should not be used.

END OF SECTION

DSWD-FOX

DIVISION 8.0 DOORS AND WINDOWS

SECTION 8.07 FINISH HARDWARE

PART 1.0 GENERAL

1.1 The general conditions, supplementary general conditions, alternates, if any, drawings and all other contract documents are a part of this section of the specifications and all provisions contained in them are so binding as though incorporated herein. Submission of proposal implies that the bidder is fully familiar with all requirements of said documents.

1.2 **SCOPE**

The work in this section shall include the furnishing of all items of finish hardware as hereinafter specified, or obviously necessary, for completion of this project excepting the items specifically excluded from this section.

1.3 **SCHEDULE**

Upon award of the contract, the successful Contractor shall submit six (6) typewritten hardware schedules to the Architect for approval. Each schedule shall contain a door index, listing each door or opening on the project and the hardware for said opening. In addition, each schedule shall have a complete keying lay-out, and explanation of the abbreviations and symbols used in the schedule. Each item of hardware listed is to be clearly identified by manufacturer, manufacturers' number and finish. Schedules not complying with the above will be rejected. The hardware supplier shall be responsible for checking and interpreting the detailed drawings to insure the proper fit and operation of all items of finish hardware.

1.4 **APPROVAL**

The Architect retains the authority to approve or reject any schedule based upon the general quality of the product submitted and its compliance with the specifications. The Contractor shall be prepared to furnish samples, at the Architect's request, of any item he proposes as substitute. Samples will be held until completion of the project and then will be returned to the Contractor.

1.5 **TEMPLATES**

The Contractor shall forward template information to all related trades requiring said information for preparation of their products to fit the finish hardware. Template submission shall be made In accordance with the latest recommended standards.

1.8 QUALITY

All specified materials furnished under this section shall be free from defects and blemishes. The hardware supplier shall repair or replace any item of finish hardware, which may prove to be defective before final acceptance of work.

PART 2.0 PRODUCTS

- 2.1 LOCKSETS: All doors shall have Schlage, Orbit design in satin chrome finish. Comfort rooms shall have Schlage A4OS privacy lock. For doors that will require deadbolts, use Schlage B16ON in satin chrome finish. Use Ives 262 flushbolts in satin chrome finish for inactive leaf doors.
- 2.2 HINGES: All hinges shall be contractor supplied and installed. Use Lawrence or Stanley, 3-1/2 " x 3-1/2' minimum size, non-ferrous hinge with stainless steel non-removable pin for door opening outside, loose pin for average doors and ball bearing for high frequency doors and doors equipt with door closers. Provide 4 pcs for door width of 0..90 meters or more, 3 pcs. for door width of 0..90 meters or less.
- 2.3 FLOOR HINGES: Pivot hinges shall be provided for all doors that swing both ways, unless otherwise specified. Pivot hinges shall be sTANLEY - 3001 in satin brass finish or approved equal.
- 2.4 FLUSH BOLTS: Stainless steel flush type, for the inactive leaf of double doors, Ives 258 or Ryobi..
- 2.5 DOOR CLOSERS: LCN 1073 series, surface mounted for all Rest Room doors, for all toilet and shower doors, and for one leaf of double doors, unless otherwise indicated.
- 2.6 CABINET HARDWARE: Cabinet pulls shall be provided for all cabinets, hardware as approved by Architect. All cabinet doors shall be provided with self-adjusting action latch. Drawers shall have painted galvanized steel drawer guides, Mckinney, Hettich or approved equal.
- 2.7 OTHER HARDWARE: Refer to Architect for all other hardware items not indicated herein, such as door silences, stoppers, pulls, and the like.
- 2.8 ALUMINUM DOOR & WINDOW HARDWARE: Shall be integrated in the manufacture of all aluminum sections, manufacturer-supplied. Submit sample for approval.
- 2.9 METAL AND FIBERGLASS DOOR HARDWARE: Shall be integrated In the manufacture of all metal and fiberglass sections, manufacturer-supplied. Submit samples for approval.

2.10 FOLDING AND SLIDING DOOR HARDWARE: Shall be Centor or an approved equivalent. Use steel wheels and galvanized steel channels. This shall be contractor supplied and installed.

2.11 OTHER HARDWARE: not indicated herein shall be approved by the architect and shall be contractor Installed and supplied.

PART 3.0 APPLICATION

3.1 All hardware shall be installed in a neat, workmanlike manner following the manufacturers' instructions. Fasteners supplied with the hardware shall be used to secure hardware to wood surfaces. Appropriate and applicable fasteners used for hardware shall be protected from paint, stains, blemishes and damage. All hardware shall be properly adjusted and checked in the presence of the Architect or his representative to show that all hinges, locks, latches, bolts and door closers operate properly. After the hardware is checked, the keys shall be tagged, identified and delivered to the Owner.

3.2 KEYS AND KEYING

All locks shall have two (2) keys with the lock number stamped upon them and with the corresponding number stamped upon the face of the lock.

After all the locks have been installed and upon completion of the work, the keys shall, in the presence of the Architect, be shown to operate their respective locks and shall be tagged correspondingly.

END OF SECTION

DIVISION 8.0 DOORS AND WINDOWS

SECTION 8.08 GLASS AND GLAZING

PART 1.0 GENERAL

9 1.1 **WORK INCLUDED:** Glass and Glazing required for this work includes, but is not necessarily limited to, float glass, plate glass, and plate glass mirrors.

10 1.2 **QUALITY ASSURANCE**

A. **QUALIFICATIONS OF INSTALLERS.** There should be at least one person, who has been thoroughly trained and experienced in the skills required and who is completely familiar with the referenced standards and the requirements of this work, who shall personally direct all installation performed under this section of the specifications.

B. **CODES AND STANDARDS.** In addition to complying with all pertinent Codes and Regulations, comply with all pertinent recommendations contained In the Glazing Manual of the Float Glass Marketing Association.

1.3 **SUBMITTALS OF SAMPLES.** Samples of each type of glass and glazing material shall be submitted

11 1.4 **PRODUCT DELIVERY, HANDLING, AND STORAGE**

A. Deliver materials to the project site in an undamaged condition and in their original unopened containers bearing label clearly identifying manufacturers name, brand and grade. Upon delivery, the Contractor shall check for any damage. Glass found damaged shall not be used in the work. Materials shall be stored out of contact with the ground, under cover and protected from damage. Label shall be affixed to each pane of glass indicating thickness and shall remain on glass until final cleaning.

. Safety glazing material shall bear Safety Glazing Material Labels.

1.5 **PROTECTION AND DAMAGED WORK**

Specified work, adjacent work and materials shall be protected against damage during progress of the work.

Glass damaged due to improper handling or setting shall be replaced at no extra cost to the Owner.

1.6 **CONDITIONS OF WORK-IN-PLACE**

Work-in-place, of which glazing is in any way dependent, must be examined and actual dimensions verified before fabrication and installation. Specified work must be coordinated with the work of other trades. Any defect, which may influence satisfactory completion and performance of the work must be reported, in writing, to the Architect. Absence of such notification shall be construed as acceptance of work-In-place. Exterior glazing materials shall not be installed in damp weather or when ambient temperature is below 40' Fahrenheit.

12

13 1.7 GUARANTEE

The Glass Manufacturer shall provide written material guarantee for a period of ten (10) years, beginning at substantial completion of project, guaranteeing glass against all defects and loss of hermetic seal. The General Contractor shall provide written guarantee for labor to replace defective glass during Glass Manufacturers 10-Year Material Guarantee Period.

14 PART 2.0 PRODUCTS

15 2.1 GLASS

- A. EXTERIOR GLASS: 6 mm. thick clear and frosted glass, refer to plans for thickness locations.
- B. INTERIOR GLASS: 6-10 mm thick, annealed float glass; 6-10 mm thick obscured float glass.
Refer to Plans for thickness locations.
- C. MIRROR: Provide 6 mm thick plate or float glass quality Q2 facial mirrors with 5 year warranty.

16 2.2 GLAZING MATERIALS: Elastomeric Sealing Compound.

17 PART 3.0 INSTALLATION

- A. Installation, including preparation by glaziers, glass positioning, edge clearances and tolerances, setting and application of glazing materials, shall comply with recommendations of the Glass Manufacturer.
- B. Before glazing, clean all rabbets to receive panels with cleaning solvent equal to Benzene or Naptha, or as recommended by Glazing Compound Manufacturer. Under no circumstances shall panels be installed in wet, dirty or oily rabbets.

**END OF SECTION
DIVISION 9.0**

FINISHES

SECTION 9.01 FINISHES

PART 1.0 GENERAL

The contents of this section apply to all section of this Division unless otherwise specified or modified.

1.1 QUALIFICATIONS

- A. Before specified material or system is installed, the manufacturer or his authorized agent shall inform the Architect, in writing, that he has familiarized himself with the Contract Documents, the environmental conditions and the intended occupancy for this specified project. Furthermore, he shall ascertain that his material or system is appropriate to the conditions to be encountered therein.
- B. Before specified material or system is installed, the manufacturer shall inform the Architect, in writing, that he is familiar with the quality of workmanship of the installer and approves him as the installer of his material or system for this specified project.

1.2 PRODUCT DELIVERY, HANDLING, AND STORAGE

- A. Deliver materials to the project site with manufacturers' labels intact and legible. Where materials are factory-packaged, same shall be delivered in original sealed containers.
- B. Handle specified Item and/or its components in such manner as to prevent damage or deformation. Properly protect same from harmful elements or damage by other work prior to its incorporation into the project.
- C. Materials shall be stored in areas where products will not be subjected to moisture or to temperature or humidity extremes.

1.3 PROTECTION

- A. The installer shall protect any existing work subject to damage during installation of specified work.
- B. The installer shall protect finished work that is readily subject to damage by subsequent work or environmental conditions.

1.4 FIELD MEASUREMENTS

Fabricators of custom work shall take actual measurements in field to verify or

supplement the dimensions indicated and shall be responsible for accurate fit of specified work.

1.5 FIELD QUALITY CONTROL

- A. Facilities shall be provided by the Contractor as needed for the proper inspection of all specified work.
- B. Improper workmanship, as determined by the Architect, shall be corrected and replaced at no additional cost to the Owner.

CONDITIONS OF WORK-IN-PLACE

Work-In-place, on which specified work is in any way dependent, shall be examined. Any defect, which may influence satisfactory completion and performance of specified work, shall be reported, in writing, to the Architect. The absence of such notification shall be construed as acceptance of work-In-place.

1.7 REPAIR OF DEFECTIVE WORK

All defective or damaged work shall be restored to initial condition. Defective or damaged Items and/or components that cannot be repaired or restored to initial condition shall be removed and replaced at no additional cost to the Owner.

1.8 CLEANING

- A. At the end of each day, the installer shall remove from the project site all accumulated trash generated by his work.
- B. Upon completion of specified work, all surfaces shall be thoroughly cleaned of dirt or other foreign materials in accordance with manufacturers latest printed directions.

END OF SECTION

DIVISION 9.0

FINISHES

SECTION 9.02 PLASTERING AND STUCCOING

PART 1.0 GENERAL

1.1 APPLICABLE PUBLICATIONS

The publications listed below form a part of this specification to the extent referenced. The publications are referred to in the text by the basic designation only.

A. Federal Specification:

SSS-S-111C Sound Controlling Materials
(Trowel and Spray Application)

B. American Society for Testing Materials (ASTM) Publications:

C 91-83 (Rev.	Masonry			Cement A)
C 14484 (Rev.	Aggregate	for	Masonry	Mortar A)
C 150-84 (Rev. A)	Portland			cement

1.2 DEFINITIONS AND SUBMITTALS

A. Term Usage: The term plastering for this work shall apply to both interior and exterior works of walls and ceilings in smooth finish. The term stuccoing for this work shall apply to exterior works of walls in textured finish.

B. Exterior walls, where indicated shall have stucco painted finish; and simulated wood concrete finish as indicated on Plans.

C. Manufacturer's Instructions: Submit manufacturers printed mixing instructions for ready plaster and stucco and acoustical plaster finish.

1.3 DELIVERY AND STORAGE

A. Deliver manufactured materials in the manufacturers' original unbroken packages or containers that are labeled plainly with the manufacturers' names and brands. Keep cementitious materials, as cement and lime, dry and stored off the ground, under watertight cover, and away from sweating walls and other damp surfaces until ready to be used.

1.4 ENVIRONMENTAL CONDITIONS

- A. PORTLAND CEMENT PLASTER AND STUCCOING: Maintain an ambient temperature of not less than 40 degrees Fahrenheit continuously where plastering and stuccoing work will be done. Maintain this temperature for not less than 48 hours prior to the application of plaster and stucco, while the plastering and stuccoing is being done and during the curing operation. In interior plastering work, maintain heat within the building until normal occupancy conditions are established. When the building is exposed to hot dry winds or day-to-night temperature differentials of 20 degrees Fahrenheit or more, cover openings that are not glazed.
- B. PROTECTION FROM SUN AND DRY WINDS: During the application of the finish coat, and for a period of 48 hours following the completion of finish coat application for any given area, the surface of the plaster and stucco shall be protected from direct sunlight and direct winds. Use of tarpaulins or other temporary means may be acceptable.

PART 2.0 PRODUCTS

- 2.1 MATERIALS: Provide materials conforming to specifications and the requirement specified.
 - A. PORTLAND CEMENT: ASTM C 150, gray Portland cement type 1,11 or III; white Portland cement, Type I or III with 1/2-inch chopped alkali resistant fiberglass strands, minimum 1 1/2-pounds per sack cement
 - B. PLASTIC CEMENT: ASTM C 150, Type I or II, except for the limitations on insoluble residue, air entrainment, and additions subsequent to calcination. Plasticizing agents may be added to Portland cement Type I and II In the manufacturing process, but not In excess of 12 percent of the total volume with 12.5 mm (1/2") chopped alkali resistant fiberglass strands, minimum 1-1/2 pounds per sack of cement.
 - C. MASONRY CEMENT: ASTM C 91 natural in color.
 - D. AGGREGATE
 - I. Sand for Portland Cement Plaster and Stucco: ASTM C 144, except gradation of sand shall conform to the following requirements:
 - a. Sand Gradation for Basecoats: Percentage Retained by weight (plus or minus 2 percent) on each sieve

Sieve Size	Min	Max
No. 4	0	0

No. 8	0	10
No. 16	10	40
No. 30	30	65
No. 50	70	90
No. 100	95	100

Sand for finish Coats: Sand for finish coat shall be white and shall be graded within the limit shown above for basecoats, except that the sand shall pass the No. 8 sieve, and for smooth the sand shall pass the No. 30 sieve.

E. WATER: Clean, fresh, suitable for domestic consumption, and free of mineral and organic substances that affect the hardening or durability of the plaster or stucco.

F. LIME: Shall be hydrated lime with the requirement that the unhydrated Calcium Oxide and Magnesium Oxide in the hydrated product shall not exceed 8% by weight, calculated on the "as received" basis.

2.2

PROPORTIONING AND MIXING: Except where specified otherwise, materials are specified on a volume basis and shall be measured in approved containers, which will ensure that the specified proportions will be controlled and accurately maintained during the progress of the work. Measuring materials with shovels' "shovel count" will not be permitted. Ready-mix plaster(s) and stucco shall be prepared for use by the addition of water only.

A. BASECOAT PROPORTION:

1. Portland Cement Plaster and Stucco Basecoats: Mix scratch coat in the proportion of one part by volume of Portland cement to not less than 2 1/2 nor more than 4 parts by volume of damp loose sand. Mix brown coat in the proportion of one part by volume of Portland cement and not less than 3 nor more than 5 parts by volume of damp loose sand. Workability shall govern the actual amount of lime and sand used in the scratch and brown coats.
2. Masonry Cement Plaster and Stucco Basecoat: Mix scratch coat in the proportion of one part by volume of masonry cement to not less than 2 1/2 nor more than 4 parts by volume of damp loose sand. Mix brown coat in the proportion of one part by volume of masonry cement to not less than 3 nor more than 5 parts by volume of damp loose sand.
Brown coat shall have the same proportion of sand used in the scratch coat or a greater proportion of sand than used in the scratch coat, within the limit specified.
3. Scratch Coat for Ceramic Tile Backing: Mix scratch coat in the proportion of one part by volume of Portland cement to 3 parts by volume of damp loose sand.

2.3 FINISH COAT PROPORTIONS:

- A. PORTLAND CEMENT PLASTER AND STUCCO FINISH COAT: Mix finish in the proportion of one part by volume of Portland cement to not more than 2 parts by volume of damp loose sand. Workability shall govern the actual amount of sand used in the finish coat, within the limits specified herein. Portland cement for stucco finish shall be white. Approved coloring compounds shall be added to produce the required color. Prepared stucco finish containing not less than one-third Portland cement by weight may be provided as approved. Where smooth trowelled finish is indicated, allow plaster to set up to the extent that it does not flow ahead or under the trowel, yet has not solidified, then trowel the face lightly to embed the granules. Do not over-trowel or burnish the surface.
- B. MASONRY CEMENT PLASTER AND STUCCO FINISH COAT: Mix finish coat in the proportion of one part by volume of masonry cement to not less than 2 parts by volume of damp loose sand.

2.4 MIXING

- A. Except where hand mixing of small patches is approved, mix materials in approved mechanical mixers of the type in which the quality of water can be controlled accurately and uniformly. While the mixer is in continuous operation, add approximately 90 percent of the estimated quantity of water, half of the sand, and all of the cementitious materials. Introduce the other one-half of the sand into the mixer in that sequence and mix thoroughly with the remainder of the water until the mixture is uniform in color and consistency. Avoid excessive mixing or agitation. Discard plaster and stucco, which has begun to set before it is used; re-tempering will not be permitted. Do not use frozen, caked, or lumped materials. Empty mixers and mixing boxes after each batch is mixed and keep free of old plaster. Mix ready-mixed plaster and stucco in accordance with the manufacturers printed instructions.

PART 3.0 EXECUTION

3.1 PREPARATION OF SURFACES:

- A. Clean surfaces to which plaster or stucco is to be applied of all projection, dust, loose particles, grease, bond breakers, and foreign matter.
- B. Do not apply plaster and stucco directly to: (1) surfaces of masonry or concrete that have been coated with bituminous compound or other waterproofing agents, or (2) to surfaces that have been painted or previously plastered.
- C. Before plaster or stucco work is started, wet masonry and concrete surfaces

thoroughly with a fine fog spray of clean water to produce a uniformly moist condition. Check metal grounds, corner beads, screeds, and other accessories carefully for alignment before the work is started. Check expansion and control joints and supporting metal structures to ensure that expansion and control joints can move unrestrained.

3.2 APPLICATION OF PLASTER AND STUCCO:

A. **GENERAL:** Plaster and stucco may be applied by hand or by machine. When a plastering machine is used, the fluidity of Portland cement plaster and stucco shall be controlled to have a slump of not more than 2 1/2-inches when tested using a 2-by 4-by 6-inch high slump cone. Subsequent to determining water content to meet this slump, do not add additional water to the mix. Conduct the slump test according to the following procedure.

- (1) Place cone on level, dry, non-absorptive base plate.
- (2) While holding cone firmly against base plate, fill cone with plaster taken directly from the hose or nozzle of the plastering machine, tamping with a metal rod during filling to release air bubbles.
- (3) Screed off plaster level with top of cone. Remove cone by lighting it straight up with a slow and smooth motion.
- (4) Place cone in a vertical position adjacent to freed plaster sample, using care not to jiggle base plate.
- (5) Lay a straightedge across top of cone, again being careful not to vibrate cone. Measure slump in inches from the bottom edge of the straightedge to the top of the slumped plaster sample.

B. **WORKMANSHIP:** Apply plaster and stucco in three coats, except as follows:

- B. Provide scratch coat, or scratch coat with leveling coat as backing for ceramic tile. Apply base coats with sufficient pressure and plaster and stucco shall be sufficiently plastic to provide a good bond to bases. Work base coats into screeds at interval of 5-to 8-feet. Plaster shall not be continuous across expansion and control joints occurring in walls, partitions, and ceilings. Plaster work shall be finished level, Plumb Square, and true, within a tolerance of 1/8 inch in 8 feet, without waves, cracks, blisters, pits, crazing, discoloration, projections, or other imperfections. Form plaster work carefully around angles and contours, and well-up to screeds. Special care shall be taken to prevent sagging and consequent dropping of applications. There shall be no visible junction marks in finish coat where one day's work

adjoins another. Plastered surfaces to which vinyl or wood base boards will be applied shall extend to ground, indicated as backing for base. Plaster will not be required behind built-in cabinets and equipment.

3.3

PORTLAND CEMENT PLASTER AND STUCCO: Apply base coats with sufficient pressure to curl the keys around the back of metal lath or wire fabric and to provide good bond on masonry or concrete bases.

A. **PLASTER AND STUCCO EXCEPT SCRATCH COAT FOR CERAMIC TILE BACKING:** Apply in three coats to a thickness of not less than 7/8 Inch. Apply the scratch coat not less than 3/8-inch thick, lightly score horizontally, and moist cure for not less than 24 hours. Apply the brown coat after the scratch coat has been aged at least 24 hours in addition to the moist curing period. Apply the brown coat to bring the base coat out to the screeds, compact and straighten to a true surface with rod and darby, and float to receive the finish coat. After the brown coat has been moist cured for not less than 24 hours and aged at least an additional 5 days, apply the finish coat to a thickness of not less than 1/8 inch. Where any previous coat has become dry, dampen the surface evenly with water, prior to the application of the next coat.

C. The finish coat for plaster shall have a trowelled finish. Finish coat for stucco shall be of the color and texture selected. Moisten plaster and stucco for 24 hours using fine fog spray of water and apply to the finish coat as frequently as required to prevent dry-out of the plaster or stucco. Do not saturate the plaster and stucco to the point where free water stands on the surface. Prevent staining of the finish coat. Provide moist curing.

A. **SCRATCH COAT FOR CERAMIC TILE BACKING:** Apply scratch coat and keep continuously damp for not less than 24 hours before tile is to be set. Scratch coat shall be applied in the thickness indicated or as necessary to bring the face of the tile to the required plane, but not less than 1/4 Inch from the face of the material it is being applied to, and with a level surface within a tolerance of 1/4 Inch In 8 feet. Apply scratch coat after substantial grounds, plugs, hangers, and other such accessories have been installed for plumbing fixtures, electrical outlets, and other fixtures and fittings have been installed that are to be secured to tiled surfaces. Apply scratch coat with sufficient pressure to ensure a proper bond and key with the base and a proper base for the setting bed. While the mortar is still plastic, cut the scratch coat with a trowel at internal vertical angles to the depth of the coat for the full height of the tile bed. Score horizontally or on one-inch centers for the extent of the tile bed. Score horizontally or cross-scratch on coats within one hour after mixing, and at no time shall the mortar be re-tempered. Protect scratch coat and keep moist during curing period. A leveling coat of the same mix specified for the scratch coat when the surface of the scratch coat is not level within the specified tolerance or when a base coat

thickness of more than 3/4 inch is required. Scratch leveling coat and cure for not less than 24 hours.

3.4 PATCHING AND POINTING

Upon completion of the building and when directed, cut out and re-patch all loose, cracked, damaged or defective plaster and stucco. Patching shall match existing work in texture, color and shall be finished flush with plaster and stucco previously applied. All point-patching of plastered and stucco surfaces and stucco plaster work abutting or adjoining any other finish work shall be done in a neat and workmanlike manner. Remove plaster and stucco droppings or splattering from all surfaces. All exposed plastered and stucco surfaces shall be left clean, in a condition ready to receive paint or other finish. Remove protective covering from floors and other surfaces, and rubbish and debris from the building.

END OF SECTION

DIVISION 9.0**FINISHES****SECTION 9.03 CONCRETE FINISH****PART 1.0 GENERAL**

1.1 **WORK INCLUDED:** This section includes the materials and procedures required to achieve finishes on concrete surfaces as stated in the schedule.

PART 2.0 PRODUCTS**2.1 SUBSTRATE MATERIAL**

A. **COMPRESSIVE STRENGTH:** Concrete floor slabs subject to live loads shall have a concrete screed with a maximum thickness of 2" (50mm) and a minimum compressive strength of 1500psi (10MPa).

2.2 FORMS

A. **PLYWOOD:** For Form Finish.

B. **PHENOLIC FILM FACED PLYWOOD:** 12-18mm thick. Use Armor-Ply as manufactured by Formaply Industries, Inc. or its approved equivalent. Use this on areas designated as having Fair-Faced Concrete Finish.

2.3 SCHEDULE OF FINISHES

A. **FORM FINISH:** Use plywood form for ceilings designated as unpainted.

B. **FAIR-FACED CONCRETE FINISH:** Use phenolic film-faced plywood for ceiling designated as unpainted. Plywood may be used up to 40 times.

C. **STEEL TROWELLED FINISH:** For floors intended as walking surfaces where indicated in Schedule or for reception of floor coverings.

D. **SMOOTH FINISH CEMENT PLASTER:** For smooth trowelled finish ceiling to receive painted ceiling finishes, provide a thin cement paste after plastering to achieve a smooth finish. Also to receive cement-sand screeding of tiles, marbles, wood flooring and the like.

E. **PLAIN CEMENT FINISH:** Plain cement finish shall be floated to a compact and smooth surface. The top surfaces shall then be steel trowelled to an even, hard surface, free from low and high spots.

F. **HARDENED CONCRETE FLOORS:** Use non-metallic aggregate anti-dust

floor hardeners.

2.4 FINISH TOLERANCES: See individual finish specifications for applicable type class.

A. Class A tolerances shall be true planes within 1/8-inch in 10ft as determined by a 10-foot straightedge placed anywhere on the slab in any direction.

B. Class B tolerances shall be true planes within 1/4-inch in 10ft as determined by a 10-foot straightedge placed anywhere on the slab in any direction.

C. Class C tolerances shall be true planes within 1/4-inch in 2ft as determined by a 2-foot straightedge placed anywhere on the slab in any direction.

PART 3.0 EXECUTION

3.1 AS-CAST PLYWOOD FINISH (Form Finish and Fair-Faced Concrete Finish)

Concrete shall be cast against forms constructed of plywood not less than 16mm (5/8") thick or of boards lined with tempered hardboard not less than 5mm(3/16") thick. The arrangement of plywood sheets or liner sheets shall be orderly and symmetrical, and sheets shall be in as large sizes as are practicable. Sheets showing torn grain, worn edges, patches or holes from previous use or other defects which will impair the texture of concrete surfaces shall not be used. All fins on the surface shall be completely removed.

3.2 FLOATED FINISH FOR FLATWORK

After the concrete has been placed, struck off, consolidated, and leveled, the concrete shall not be worked further until ready for floating. Floating shall begin when the water sheen has disappeared, and/or when the mix has stiffened sufficiently to permit the proper operation of a power driven float. The surface shall then be consolidated with power driven floats. Hand floating with wood or cork-faced floats shall be used in locations inaccessible to the power-driven machine. Trueness of surface shall be checked at this stage with a 10-foot straightedge applied at not less than two (2) different angles. All high spots shall be cut down and all low spots filled during this procedure to a Class B tolerance. The slabs shall then be refloated immediately to a uniform, smooth, granular texture.

3.3 TROWELED FINISH FOR FLATWORK

A. Where a troweled finish is specified, the surface shall be finished first with power floats, as specified above where applicable, then with power trowels, and finally with hand trowels.

B. The first troweling after power floating shall be done by a power trowel and

shall produce a smooth surface which is relatively free of defects which may still contain some trowel marks. Additional troweling shall be done by hand after the surface has hardened sufficiently. The final troweling shall be done when a ringing sound is produced as the trowel is moved over the surface.

- C. The surface shall be thoroughly consolidated by the troweling operations. The finished surface shall be free of any trowel marks, uniform in texture and appearance, and shall be planed to a Class A tolerance.
- D. On surfaces intended to support floor coverings, any defects of sufficient magnitude to show through the floor covering shall be removed by grinding.
- E. All edges and tooled joints shall be finished with a 3mm (1/8") radius tool.

3.4

SMOOTH RUBBED FINISH

- A. Smooth rubbed finish shall be produced on freshly hardened concrete. All necessary patching shall have been done immediately after forms have been removed and rubbing shall be completed not later than the following day. Surfaces shall be wetted and rubbed with carborundum brick or other abrasive until a uniform color and texture is produced. No cement grout or slush shall be used other than the cement paste drawn from the "green" concrete itself by rubbing process.
- B. Rubbing procedure shall be approved by the Architect before starting the work.

END OF SECTION

DIVISION 9.0 FINISHES

SECTION 9.06 CERAMIC TILES

PART 1.0 GENERAL

1.1 **SUBMITTALS:** Submit samples of each type and color of Ceramic Tiles, grout and joint fillers. Samples of tile patterns shall be not less than 600 mm x 600 mm in size.

1.2 **PROTECTION AND DAMAGED WORK:** Specified work and adjacent work and materials shall be protected against damage during progress of specified work until completion. Spaces, in which tile work is being set, shall be closed to traffic and other work until tile has firmly set. Suitable notices shall be posted or other provisions made to the effect that no one shall work around freshly-tiled walls nor walk upon freshly-tiled floor for not less than seven (7) days after the tile has set. Damaged or defective work shall be repaired or replaced to the Architect's satisfaction. Cracked, chipped or otherwise defective tile will not be accepted.

PART 2.0 PRODUCTS

2.1 CERAMIC TILE

18

19 **A. Local Ceramic: Glazed and other unglazed tiles**

Sizes for tiles:

6mmx200mmx200mm

6mmx300mmx300mm

6mmx400mmx400mm

6MM X 600 X 600MM

Refer to Schedule of Finishes for sizes.

B. DESIGN: Ceramic tiles shall have the sizes indicated on the plans and all accessory tiles shall be in matching size; all accessory tiles shall be as required for conventional mortar installation.

H.

I. C.COLORS: All ceramic tiles shall be in colors selected by the Architect and Interior Designer from the Manufacturers range of standard colors and patterns in the specified products.

MORTAR. All mortar setting bed for use on floors and walls shall be a blend of Portland cement, graded sand and additives, or equal.

2.3 GROUT

D. A. COLOR: Grouting shall be in colors selected by the Architect form the

manufacturer's standard range of colors.
OTHER MATERIALS

All other materials, not specifically described but required for a complete and proper tile installation, shall be as selected by the Contractor, subject to the approval of the Architect.

PART 3.0 EXECUTION

CONDITION OF WORK-IN-PLACE: Refer to Section 9.01.

3.2 CERAMIC TILE FLOORS, CURB, WALLS AND BASE:

A. Mix and use proprietary or trade-marked materials in strict accordance with Manufacturers' instructions, unless otherwise specified. Cut and drill tile for proper fitting around all equipment-in-place without damaging work. Rub down with an abrasive stone the exposed sharp edges of cuts. Grind and fit carefully at intersection, against trim, finish, and built-in items. Fit tile closely around outlets, pipes, fixtures and fittings, so that plates, collars and escutcheons will overlap cuts. Before applying mortar setting bed, establish border lines, if any; center field work in both direction to permit laying pattern with minimum of cut tiles. Lay floor without borders from center lines outwards. Make necessary adjustments at walls.

B. Install all trims required to complete the work.

C. The tile base shall join the floor surface with a cove shape. The top of the base shall be a bullnose.

3.3 SETTING

C. A. Set ceramic floor tile firmly in setting bed, for a true surface. Joints shall be straight, level, perpendicular, and of even width not exceeding 1/16 inch. Joints in floor and wall tile work shall be level.

D. B. Setting bed for mortar-set floor tile shall be placed to a thickness of 3-6 mm on a working area of not more than 1 sq. m. Solid-bed fixing Is recommended for wet conditions and ceramic floor tiles, but, otherwise, the adhesive should be horizontally ribbed with a notch trowel before fixing the tiles.

E. C. Fix tiles by pressing into place, beginning at the bottom in the case of wall tiles, and at center markings in the case of floor and pool tiles. Make sure that the back of each tile is not less than 75% in contact with the adhesive.

F. D. Clean off surplus adhesive with a damp cloth. Leave for a minimum of 24 hours to set before grouting ceramic wall tiles with Grout. When fixing ceramic floor tiles, no traffic should be allowed for 4 days after completion.

3.4 GROUTING

A. Mix the grout powder with water to a smooth thick consistency. Avoid over-wetting. Leave to stand for about 15 minutes before using.

G. B. Apply to the tile joints with the squeegee, brush, or sponge working the grout in thoroughly to ensure total compaction. Remove surplus grout with a damp sponge.

END OF SECTION

DSWD-FOX

DIVISION 9 FINISHES
SECTION 9.07 LOCAL AND OTHER STONES

PART 1.0 GENERAL

1.1 **WORK INCLUDED:** This section includes the furnishing, delivering, and installation of all Local Stones and the like.

1.2 **SUBMITTALS:**

- A. Samples of approved sizes, design and pattern.
- B. Shop drawings showing layout and pattern and dimensions.
- C. Grouting materials.

PART 2.0 PRODUCTS

2.1 **MATERIALS:** Local Stones as indicated on plans. Refer to plans for exact location. Present samples to Architect for approval.

2.2 **SIZE:** Verify Architect and submit sample of finish for approval.

2.3 **GROUT:** Shall have a minimum width of 3mm to a max. of 16mm, ABC tile grout or Architect's approved equal.

2.4 **SETTING BED:** Mortar setting bed shall be 25mm minimum to 31mm, 1:2 mixture. Grouting shall be in colors selected by the Architect from the manufacturer's standard range of colors.

2.5 **PATTERN:** Refer to drawings or as approved by the Architect.

PART 3.0 EXECUTION

3.1 FOR EXTERIOR WALL:

A. **PROTECTION:** Protect specified work and adjacent work and materials against damage during progress of specified work until completion. Post suitable notices or make other provisions to the effect that no one shall work around freshly-laid walls not less than seven (7) days after the stone has set. Damaged or defective work shall be repaired or replaced at no additional cost to the Owner. Cracked, chipped, or otherwise defective stone will not be accepted.

B. **SETTING:** Set stone firmly in setting bed for true surface. Joints should be straight, level and of even width not exceeding 15mm. Joint depth is approximately 6mm to 8mm.

C. **GROUTING METHOD:** Grout float method: force a maximum amount of grout (1 part cement to 2 parts fine graded sand) into joints.

END OF SECTION

DIVISION 9.0 FINISHES

SECTION 9.08 CEILING SUSPENSION SYSTEM

PART 1.0 GENERAL

1.1 DESCRIPTION

- A. INCLUDED all items and components forming any portion of the Suspended Ceiling Subsystem and all work to install same.
- B. LOCATION: All areas designated in Finish Symbol on Drawings to receive Acoustic Type Ceilings.

1.2 QUALIFICATIONS: Refer to Section 9.01 FINISHES.

1.3 SUBMITTALS

- A. SHOP DRAWINGS: Submit copies of ceiling layout indicating the location of all light fixtures, diffusers, etc. Show details of installation, including all special conditions, such as hanger spacing, fastening details, splicing method for main and cross runners, change in levels, and supports at ceiling fixture. Lay out system to permit as large border units as possible.
- B. SAMPLES: Submit representative samples of all components of each type of ceiling subsystem.
- C. MAINTENANCE PROGRAM: Submit manufacturers' latest printed recommendations for proper owner maintenance program.

1.4 PRODUCT DELIVERY, HANDLING, AND STORAGE: Refer to Section 09000 FINISHES.

1.5 ENVIRONMENTAL CONDITIONS

- A. Installation of any and all dampening materials shall be installed prior to the installation of specified work.
- B. In areas where specified work is to be installed, maintain uniform humidity and temperature for at least twenty- four (24) hours prior to, during, and after installation

PART 2.0 PRODUCTS

2.1 LAY - IN ACOUSTIC CEILING TILE SYSTEM (Exposed T- bar system) : Acoustic ceiling panel shall be CELOTEX Acoustic Ceiling System, distributed by Man's Work Trading or approved equal.

A. ACOUSTIC CEILING TILES

1. Description: Acoustically efficient, fire-resistant, durable ceiling board faced with vinyl film.
2. Size: 24"x48"x5/8"
3. Design: CELOTEX, for Architect's approval
4. Thermal Resistance: 1.6 (R Value)
5. Noise Reduction Coefficient; 0.50 - 0.60
6. Sound Absorption Coefficient;

<u>AS 1045</u>	<u>Frequency (Hz)</u>
0.42	125
0.36	250
0.55	500
0.69	1000
0.56	2000

7. Light Reflectance Value: 70 % -74 %

B. EXPOSED T-BAR CEILING SYSTEM

1. Treatment : All Metal frames shall be hot-dipped galvanized
2. Main T-bar : 32 mm x 24 mm x 0.30 mm thick baked enamel white
3. Cross T- bar : 25 mm x 24 mm x 0.30 mm thick, baked enamel white
4. Hanger wire : 2.0mm diameter
5. Hold down Clip : 0.30 mm thick
6. Wall Moulding : 18 mm x 18 mm x 0.40 mm thick, baked enamel white

PART 3.0

EXECUTION

3.1

INSTALLATION

Suspended acoustic ceiling system shall be installed in exact pattern indicated and detailed on the drawings, and in strict accordance with manufacturers' latest printed instructions. Hangers shall be spaced so that maximum deflection does not exceed 1/360 of span between same. Ceiling shall be re-leveled as required.

3.2

CUTTING AND FITTING

All cutting and fitting of acoustical materials shall be done as required to complete the specified work and to accommodate the work of Other Trades.

3.3

REPAIR OF DEFECTIVE WORK: Refer to Section 9.01.

3.3 CLEANING: Refer to Section 9.01.

END OF SECTION

DIVISION 9.0 FINISHES

SECTION 9.09 PAINTING

PART 1.0 GENERAL

1.1 DEFINITION OF PAINT

The term "PAINT " as used herein, includes emulsions, enamels, paints, varnishes, sealers, and other coatings, whether used as prime, intermediate, or finish coats.

1.2 QUALIFICATIONS: Refer to Section 9.01.

1.3

1.4 QUALITY ASSURANCE

A. The Owner reserves the right to subject material samples to test at his expenses. If such material tests do not meet the specified standards, the cost will be charged to the Contractor.

B. Number of coats, where specified, is minimum. Contractor shall apply as many as required to meet specifications for solid, uniform appearance. Where film thickness in mils is specified, spot checks will be made to determine compliance with specified thickness.

1.4 SUBMITTALS

A. Submit 2 samples of each and every color or finish (including all coats). Where the same color or finish is to be applied over different materials, samples of each shall be submitted on different materials, where practical.

B. Sample size shall be a minimum of 150 mm x 150 mm (6" x 6").

1.5 PRODUCT DELIVERY, HANDLING, AND STORAGE

A. Specified materials shall be delivered to the job site bearing manufacturers' name, brand name, type of paint, analysis showing all important constituents of the paint, color of paint and instructions for thinning.

B. Specified item and/or its components shall be handled in such manner as to prevent damage. The same shall be properly protected from harmful elements or damage by other work prior to its incorporation into the Project.

C. Store materials in a well ventilated space designated for the storage and mixing of paint. Materials delivered to the site shall be properly stored as to minimize exposure to extremes of temperature.

1.6 PROTECTION

- A. Paint materials shall be properly protected from damage, providing for adequate storage space. Take all necessary precautions to prevent fire, such as keeping oily rags in U. L. approved metal containers or removing from building at the end of each day's work.
- B. All work fittings, furniture, etc., are to be suitably protected during execution of the work. Splashes on floors, walls, etc. are to be removed during progress of work and on the whole, left clean and perfect upon completion.
- C. No exterior or exposed painting shall be carried out under adverse weather conditions, such as extremes of temperature, during rain, fog, etc., or if there is excessive dust in the air.

D. LEAD CONTENT AND WARNING LABELS

- 1. The material manufacturer shall state the lead content on the label of any paint product container based on metal percentage of total solids.
- 2. The label of any paint product exceeding 0.5% lead content shall include the following statement: "This paint contains more than 0.55 lead content and shall not be used on surfaces accessible to children."

1.7 FIELD QUALITY CONTROL: Refer to Section 9.01.

1.8 REPAIR OF DEFECTIVE WORK

- A. All defective or damaged work shall be restored to initial condition.
- B. All voids, cracks, nicks, etc., will be repaired with proper patching material and finished flush with surrounding surfaces.
- C. Marred or damaged shop coats on metal shall be spot-primed with appropriate metal primer.
- D. Defective or damaged items and/or components , which cannot be repaired or restored to initial conditions, shall be removed and replaced to the satisfaction of the Architect at no additional cost to the Owner.

1.9 MECHANICAL AND ELECTRICAL ITEMS

Painting Contractor shall be responsible for painting mechanical and electrical items as specified herein. No name plates, rotating shafts, bearing bronze, electrical windings or valve stems shall be painted, nor shall any part furnished in nickel or chrome plated be painted.

1.10 CLEANING

Upon completion of the building, the Painting Contractor shall remove all paint spots from all finished work, remove all empty cans and leave the entire premises free from rubbish or other debris caused by his work. He shall remove his equipment from the premises. He shall clean off all glass free from paint spots and smears and shall present the work clean and free from all types of blemishes.

PART 2.0 PRODUCTS

2.1 GENERAL

- A. Materials are specified to establish the standards of grade and quality desired for the work, principal pigments and vehicle types and minimum percentage of solids content by volume.
- B. The top quality / first class paints of the following brands:
 - 1. Boysen Paints
 - 2. Nation Paints
- C. The products of Manufacturers not named may be submitted for use provided they are equal in quality and grade to the primers and finishes specified as approved by the Architect. If substitute paint products are desired, a statement shall be submitted to the Architect giving the Manufacturers name, proposed primer and finish for each paint system, analysis for each type of paint, and the use or uses intended. Failure to submit such statements will be cause for rejection.
- D. In cases where the name of a brand or supplier is mentioned under a particular specification, only paint or primer of that manufacturer is acceptable and no substitution shall be permitted on the grounds that the brand specified is not available in the local market. Materials of one manufacturer shall not be applied over that of another, except In the case of shop primer coat.

2.2 COLOR, GLOSS AND TEXTURE

Refer to Finish Schedule. All work Is to be completed without deviation from these unless written approval Is received from the Architect. No extra cost shall be allowed because of the color variety scheduled.

PART 3.0 EXECUTION

3.1 GENERAL

- A. Work-in-place, on which specified work is to be applied, shall be examined to insure that conditions are satisfactory for application of specified materials. Any defect, which may influence satisfactory completion of

specified work, shall be report, in writing, to the Architect. Absence of such notification will be construed as acceptance of work-in-place.

- B. Do not apply exterior paint in damp or rainy weather or until surfaces have thoroughly dried from the effects of such weather.
- C. Before start of painting, remove finish hardware, accessories, plates, lighting fixtures, and similar Items, as approved by the Architect, except UL Labels on Fire Door and Frames, which must not be removed. Use only workmen skilled in the applicable building trade for removal and reinstallation of finished item in-place.
- D. The following items shall be masked or protected with suitable covering:
 - 1. Sealing₁ caulking and glazing compounds (unless otherwise directed by the Architect).
 - 2. Glass.
 - 3. Gauges, thermometers and other recording devices.
 - 4. Moving parts of machinery and other mechanical equipment - such as: shafts, couplings, valve stems, and the like.
 - 5. Coated decorative sheet metal work.
 - 6. Sprinkler heads and the like.
 - 7. U.L. Labels

3.2 SURFACES PREPARATION AS APPLIED TO VARIOUS SUBSTRATE

A. WOOD:

New Surface:

- Surface to be painted should be clean and dry, free from oil, grease, dust, dirt, contaminants and all loose girt or mortar; sand rough edges remaining, countersink nail heads for putty applications.
- Dust off surfaces completely then wipe with a clean rag.

Repainting:

- Remove scaling, flaking, blistering, and peeling off paint either with the use of **PAINT AND VARNISH REMOVER**, wire brushing, scraping, or water blasting. Let dry.
- For glossy areas, sand and dust clean.
- In case of mildew infestation, treat with **FUNGICIDAL WASH SOLUTION** by swabbing or brushing. To ensure proper treatment, allow either solution to remain in surface for 24 hours. Brush off and rinse with water.

B. METAL:

New Surface:

- Surface to be painted should be clean and dry, free from oil, grease, dust, dirt, wax, solder flux, and other contaminants by wiping with mineral spirits or paint thinner.
- Remove rust by wire brushing, sanding or scraping.
- Where maximum performance of protective coatings is necessary (e.g. Industrial Plants), prepare surface by blast cleaning.

Repainting:

- Sand wire brush or scrape rusted metals and apply **METAL ETCHING SOLUTION # 71** to remove rust. Let it stay for 10 to 15 minutes. Be sure to wash off surface thoroughly with mineral spirits, letting it dry before applying paint. Primer should be applied a few hours after application of B-71 before rust sets in.

C. CONCRETE:

New Surface:

- Surface to be painted should be clean and dry, free from oil, grease, dust, dirt, contaminants and all loose girt or mortar.
- Treat with **MASONRY NEUTRALIZER**. Mix (1) liter of B-44 with (16) liters of water. Apply liberally by brush and let dry overnight.
- Rinse with water to remove white crystals that form on the surface. Let dry.

D.CAULKING:

- Oil-Based caulking compound surfaces to be painted shall be prepared by removing all foreign materials.

3.3

PAINT APPLICATION

A. GENERAL: Specified work shall be done by skilled painters in a workmanlike manner. All spaces shall be broom-cleaned before painting is started. Surface to be painted shall be clean, dry, smooth and adequately protected from dampness. Each coat of paint shall be allowed to dry at least twenty-four (24) hours before succeeding coat is applied. Finish work shall be uniform, of approved color, smooth and free from runs, sags, defective coverage, clogging or excessive flooding. If surfaces are not adequately covered, as determined by the Architect, further coat shall be applied to the satisfaction of the Architect. Edges of paint adjoining other materials or colors shall be sharp and clean without overlapping.

B. PAINT MIXING: Paint mixing and thinning shall be done only in accordance with directions of Manufacturer. Paint must be strained free from

all skin and extraneous substances and shall be thoroughly mixed in a clean container during use.

- C. METHODS OF APPLICATION: Exterior first coats and Interior first coats shall be applied by brush, except on shop-primed surfaces, which shall be applied by brush or roller. All primer shall be applied by brush. Succeeding coats over field-primed surfaces and all coats over shop-primed surfaces may be applied by brush roller or spray. Distemper brushes are to be of approved type and less than 15 cm in width. Rollers for applying enamel shall have a short nap. Spray equipment shall be as recommended by the manufacturer of the paint used. Areas inaccessible to spray painting shall be coated by brushing or suitable method.
- D. COATING: Consecutive coats of paints are to be slightly differing tints except in the case white. Each coat shall be allowed to harden before the next is applied. Rubbing down between coats is to be done with fine abrasive paper.
- E. WOOD FINISHING: Wood to have natural satin varnish finish shall be stained as required and sealed as soon as such Items are delivered to the job site. Seal all ends to exclude moisture. Knotting shall be carried out by using shellac dissolved in spirit or approved ready mixed compound.
- F. DEFECTS IN MASONRY, CONCRETE, PLASTER AND GYPSUM BOARD: Small cracks, holes, and other similar imperfections in masonry, concrete and plaster surfaces, which show up after the prime-sealer has been applied to the surface, shall be filled with an approved sparkling compound before application of succeeding coats.
- G. WOODWORK AND METALWORK: Primed or undercoated woodwork and metalwork shall not be left in an exposed or unsuitable situation for an undue period before completing the painting process. Stopping and filling shall be deemed to be included for all metal works, plaster works, and wood work specified to be used to produce a surface ready for priming and painting.
- G. FINAL TOUCH-UPS: Upon completion, finish work shall be touched-up and restored where damaged and left in good condition.

PART 4.0 PAINTING SCHEDULE

4.1 GENERAL

Painting Systems shall be applied to surfaces as scheduled. All walls to be painted shall be plastered prior to painting. All under slabs to be painted shall have fair-faced concrete.

4.2 FILM THICKNESSES: As recommended by paint manufacturer for the paint specified, includes thickness in mils and number of coats.

4.3 SCHEDULE

A. MASONRY AND CONCRETE

1. Interior and Exterior Surfaces

Textured Finish (flat, semi – gloss, gloss paint). Treat with masonry neutralizer.

1st Coat : Flat Latex # 701
Putty : Masonry Putty
2nd Coat : Latex (flat, semi-gloss, gloss paint)

C. WOOD SURFACES

1. Painted Doors, jambs, cabinets, shelves (Semi - gloss finish, lacquer type spray)

1st coat : Primer Surfacer
2nd coat : Lacquer Spot Putty (if required)
3rd coat : Lacquer Primer Surfacer on puttied areas.
4th coat : Automotive Lacquer Enamel

2. Plain painted surfaces such as walls & partitions (Semi-gloss finish-Alkyd type)

1st coat : Flat wall Enamel
Putty : Glazing Putty
2nd coat : Semi-Gloss Enamel
3rd coat : Semi-Gloss Enamel

D. METAL SURFACES

Gloss Finish (Alkyd Type) for G. I. Pipes, etc.

1st coat : Metal Primer Zinc Chromate
2nd coat : Glazing Putty
3rd coat : Quick Dry Enamel

2. Gloss Finish (Epoxy type) for metal elements and doors, wrought iron grilles, W. I. railing , B. I. and G. I. pipe handrails

1st coat : Epoxy Primer White
2nd coat : Epoxy Enamel
3rd coat : Epoxy Enamel

END OF SECTION

DSWD-FOX

DIVISION 9.0 FINISHES

SECTION 9.10 WATER REPELLANT

PART 1.0 GENERAL

1.1 SCOPE. Work includes supply and installation of water repellant on all local stones, slate stones, and brick on wall installation and as indicated.

1.2 SUBMITTAL

A.MATERIAL SAMPLE: Water repellant as applied on specified brick sample, not less than 300 mm x 300 mm (12"x 12").

B.BROCHURE: Latest manufacturer's brochure containing product characteristics and description.

PART 2.0 PRODUCTS

2.1 MATERIAL: A solvent containing colorless one- component preparation on base of alkoxy Silan. It shall be used to impregnate and to seal cement bound surfaces. The water repellant shall have extremely low viscosity, and because of its high capillary action, it forces itself deeply into the foundation materials, and fills all pores and capillaries. Cement surfaces are therefore rendered hydrophobic and sealed against damp water and water solvent substances. The penetration is impeded, but, is not completely prevented. Use Euxit 451 water repellant as manufactured by Rebtrade International Corporation on all stonewalling and skirting.

2.2 PRODUCT TECHNICAL DATA

Specific gravity at 20° C (g / cu.m.) : 0.8

Solvents:

Ethanol

Color: colorless

Shelf life in months 20° C:
min. 12

Storage: well closed, cool

Precautions: flammable liquid

2.3 TYPICAL RESULTS

	Impregnated with Euxit 451	Without Treatment of Euxit 451
Diffusion Resistant Factor	106	120

Vapor Resistance (h/m)	1.32	150
Water Absorbing Property	0.017	0.761
Kg. / sqm. / h	0.051	0.471

PART 3.0 EXECUTION

3.1 APPLICATION

Euxlt 451 can be sprayed with an airless - gun, applied by a roller or brushed on. The surface should be cleaned and dried to allow good penetration.

3.2 CONSUMPTION

Depending on the absorbency of the surface, consumption is approximately 200 - 400 g / sqm. The total amount should be applied in 1-3 coating with intervals of about 15 minutes between each. (Wet on wet).

END OF SECTION

DSWD-FOK

DIVISION 9.0 FINISHES

SECTION 9.11 WOOD PRESERVATIVE

PART 1.0 GENERAL

1.1 **SCOPE OF WORK.** Work includes supply and application of wood preservative on all exterior wood works, on exposed wood rafters, and on areas where indicated on plans.

1.2 **SUBMITTALS**

A. **BROCHURE:** Latest manufacturer's brochure on product characteristics and method of application.

B. **SAMPLE:** 150 mm x 150 mm samples of wood applied with preservative on different stair finishes for approval.

PART 2.0 PRODUCTS

2.1 **MATERIAL:** Material shall be thin liquid, ready for use, combined decorative, water repellent and wood preserving stain, which soaks into softwood, hardwood, etc., and emphasizes the grain and natural characteristics of the wood. It shall be a solvent-based decorative treatment that dries to a silk-matte finish. Use Xyladecor decorative wood preservative as manufactured by Bayer/Pacific Paint & Oil Manufacturing on all exposed wood materials, such as T & G eaves, posts, window and door frames and other exposed wood parts, including indigenous materials as indicated.

2.2 **PROPERTIES**

A. **Water repellent:** provides protection against wood rotting fungi, wood-boring insects, mold and sap (blue) stain. The XYLADECOR type U473 ensures In addition preventive protection against TERMITE attack (test certificate available upon request).

B. **Pigments** are non-obliterating and light fast.

C. As XYLADECOR does not form a surface coating it cannot peel, crack, flake or blister.

D. The moisture regulating properties of XYLADECOR permit the evaporation of excess moisture from the wood without impairing the efficiency or appearance of the treatment.

2.3 **FLAMMABILITY:** Flash point is above 55 C (131°F). During handling and application keep away from naked flames and lights. When dry, there is no increase combustibility of treated wood.

2.4 SPECIFIC GRAVITY: 0.88 to 0.91 depending on the color.

PART 3.0 EXECUTION

3.1 COVERING RATE

- A. 200 - 250 ml / sq.m. in at least 2 coats to ensure comprehensive protection (1 liter for 5-6 square meters).
- B. 110 ml / m² to ensure preventive protection against blue satin and Powderpost beetle (1 liter will suffice for about 9 square meters on interior woodwork.)

3.2 APPLICATION

- A. Do not use knotting, primers or undercoats. Apply directly to bare wood.
- B. Apply by brush, spray or by dipping in an open trough or tank to achieve the total covering rate (or loading).
- C. Thoroughly shake the can before and during use. Keep the fluid in tanks, troughs and cans stirred during use.
- D. By brush: Apply in at least two full brush coats laying the XYLADDECOR on to the wood rather than brushing out (as for example, with paint). Leave each coat for about 30 minutes, depending on the weather, absorption rate, etc., and lightly brush or wipe over once in the direction of the grain to remove excess material and to smooth out any runs.
- E. By dipping: Dip the timber in the preservative for 1-1/2 to 2 minutes varying the time required according to the absorbency of the wood (due to moisture content, species, etc.). Stand the timber on end and allow to drain. If necessary, lightly brush the surface once in the direction of the grain before it is dry. After fixing the timber in site, apply a further coat of the preservative to the exposed external faces of brush.
- F. By spray: Use a coarse nozzle (about 1.5 mm giving a stream of material rather than a fine atomizing type paint spray). Use at a working pressure of approximately 3.1 kg / sq.cm. (44 lbs. / sq.in.). Apply the material in a similar manner to (D) above. Spraying is not generally recommended for planed surfaces.
- G. If a very even color finish is requested on wood with varying degrees of absorbency, apply colorless before treatment with pigmented preservative. Colorless is not recommended for use on its own on woodwork exposed to weathering. It will not prevent the gradual graying of wood, even with tropical hardwoods.

- H. Softwood outside: Apply pigmented preservative in at least 2 coats. If necessary, apply once for pre-treatment.
- I. Hardwood outside: Apply pigmented preservative at least 3 coats; these woods take up only a small amount of material per application. No pre-treatment with colorless.
- J. Wood inside: Apply one or several coats, depending on the color effect desired. Mixtures with colorless are possible in any ratio.
- K. Exterior doors: Apply pigmented preservative in at least 3 coats. The color shades Teak, Nut-tree, Mahogany, and Chestnut are preferred.
- L. Wood subjected to severe weathering: Three coats of pigmented preservative are required since a minimum amount of pigment is necessary to protect the timber surface against the adverse effect of sunlight.
- M. Strongly resinous wood: Prior to treatment, it is recommended to wash down surface with nitro-thinner.
- N. Exposed end-grains shall be protected against penetration of water by applying several coatings of preservative or of a varnish in same color tone. When using on external timber cladding of naturally colored wood adjacent to plaster or masonry surfaces beneath, care should be taken to apply the material very carefully on all sides, including sealing of the end-grain with a pigmented varnish (at least two coats). This is to prevent the natural dyes contained in the wood to be washed out, run down or stain adjacent surfaces. XYLADDECOR, however, is not subject to leaching or washing out when completely dry; there is no risk of adjacent surface being stained.
- O. Close cans and cover dipping tanks well after use. In case of longer standstills, fill back into tightly closed containers. Partly-used cans have a limited life.

3.3 DRYING TIME

- A. 1 to 2 days
- B. Warm, dry weather and conditions, where there is a good air movement, will accelerate drying.
- C. Cold, damp conditions and badly ventilated areas will retard drying, as will excessively damp and absorption-resistant wood.

3.4 MOISTURE CONTENT: Preservative may be used on wood with a moisture content of up to 25% on softwood and 20% on hardwood. To ensure

dimensional stability of windows, moisture content should not exceed 15%.

3.5 ODOR: After drying and airing, preservative must be odorless.

3.6 ADJACENT MATERIALS

- A. Preservative should not corrode nor adversely affect metals, masonry, brick, plaster, etc., but splashes should be removed with white spirit whilst wet to prevent staining.
- B. Cover polystyrene and similar plastic materials to prevent damage and staining.

3.7 GLUE

- A. Preservative should not upset existing glue lines.
- B. Wood treated with preservative may be glued after the preservative is completely dry. Because differing factors (such as types of glue, variable drying periods caused by differing uptake of preservative etc.) may influence the efficiency of the glue bond, a trial is strongly recommended in cases of uncertainty.

3.8 FILLERS: XYLADDECOR can be applied to plastic wood, exterior quality stopper and conventional wood fillers.

3.9 CARE OF EQUIPMENT

- A. Clean brushes, spray equipment etc., immediately after use with white spirits, turps substitute or similar material.
- B. Do not let preservative dry off on equipment or material lines.

3.10 BLEACHED FINISH: Use wood bleach solution #1 and 2, Nation, as manufactured by Pacific Paint and Oil Manufacturing, prior to application of 3 coats decorative for all exterior woodworks. (Group B).

3.11 USE ON WOOD PREVIOUSLY PAINTED, CREOSOTED, ETC.

Preservative may be used on wood, which has been painted, varnished, creosoted, etc., provided the following points are observed:

1. Painted or varnished wood: All surface coatings and primers must first be completely removed by chemical stripper and/or by sanding or burning, taking care not to scorch the wood. It is good practice to lightly scrape the wood surface, thus exposed after stripping surface coats, to remove ingrained particles of paint and varnish.

2. Surface coatings left on the wood will impair the effect and efficiency of preservative.
3. If in any doubt, apply to a trial area first.

Creosoted or preservative-stained wood: Wood previously treated with creosote or tar-oil-type products may be treated with preservative provided they have weathered. The darker preservative colors are usually preferred in such cases. Where it is intended to use lighter colors, and in cases where the creosote etc., has not “weathered out” to a great extent, apply preservative first to a trial area.

Wood treated with other proprietary brands of wood preservative again which has “weathered out” may generally be treated with preservative, but in cases of doubt a trial application is recommended.

3.12 USE OF VACUUM PRESSURE-TREATED WOOD

- A. Where it is intended to use preservative on timber, which has been treated by a vacuum pressure preservative and/or salt-type flame retardant system (including double vacuum systems), this is suitable subject to the moisture content of the wood at the time of treatment. (See heading 7)
- B. The use of preservative on timber, which has been treated by a vacuum pressure preservative, will be satisfactory, provided that oil-type preservatives have been used or those types of salt, which are fixed to the wood fiber. The use of preservative on exterior timber, which has been treated with ‘mobile’ salts, is not recommended because discoloration can be expected.

3.13 OVERPAINTING: Preservative need not, but may be overpainted when dry with normal paint systems, polyurethane and clear varnishes. In these cases, the moisture content of the wood at the time of overpainting should not exceed 15%.

3.14 SURFACES SUBJECTED TO MECHANICAL WEAR AFTER TREATMENT OF PRESERVATIVE: Surfaces, such as floor, stairs, doors and chairs, etc., subject to mechanical wear should be over-coated with a final coat of clear polyurethane varnish.

3.15 COLOR RANGE

- A. All colors may be intermixed by first shaking or stirring to mix.
- B. The darker the self-color of the wood to which preservative is applied, the darker is the finished color tone after treatment.
- C. Always apply on a trial area first to see the color obtained.
- H. D. Lighter colors may be obtained by mixing Colorless with any of the preservative colors. These should be used on internal surfaces only.
- E. Do not dilute with solvents.

3.16 PRECAUTIONS: For wood protection, use in accordance with the manufacturers' instructions only. Misuse will create health hazards! Store away from all foodstuff and animal feed in a place inaccessible to children. Do not fill into eating, drinking or cooking vessels.

It is recommended that impermeable protective gloves and protective clothing, tight fitting goggles and a respirator are worn during spraying.

Treated timber is harmless to humans and domestic animal (but avoid contact with unpacked foodstuff and animal feed). Do not treat wood intended for use in bee-houses or the Interior of green-houses. Do not wet plant-life. Provide for ample ventilation before treated stables are reoccupied. During storage and application observe any statutory regulation and ground/surface water contamination.

END OF SECTION

DIVISION 10 SPECIALTIES

2 SECTION 10.01 MISCELANEOUS SPECIALTIES

PART 1.0 GENERAL

1.1 **SCOPE/WORK INCLUDED:** This section includes specifications on plumbing fixtures, fittings and accessories, selected lighting fixtures, louvers, and others.

1.2 **SUBMITTALS:** (As Applicable)

A. **SHOP DRAWING:** Indicating layout, dimensions, and other pertinent construction and erection details.

B. **SAMPLES:** Submit sample sections of materials, samples of finishes, each with color standards with specified manufacturers.

C. **BROCHURE:** Submit manufacturer's latest manual describing materials, fabrication and methods of installation.

1.3 **EXAMINATION AND ACCEPTANCE OF WORK-IN-PLACE**

Examine work-in-place on which specified work is in any way dependent to insure that conditions are satisfactory for installation of specified work. Report, in writing, to the Contractor and the Architect any defect which may impair satisfactory completion and performance of included work.

1.4 **FIELD MEASUREMENTS**

Take field measurements to verify or supplement dimensions indicated. Be responsible for accurate fit for specified work.

1.5 **PROTECTION AND DAMAGED WORK**

Protect specified work from damage during transportation, storage at Project Site and throughout tenure of work. Protect adjacent work and materials from damage during progress of specified work. Damaged work shall be repaired or replaced to complete satisfaction of the Architect. Furnish receipts for all loose detachable parts.

PART 2.0 PRODUCTS

2.1 **PLUMBING FIXTURES:** All plumbing fixtures shall be American Standard or Architect's approved equal, with colors of fixtures subject to Architect's approval.

- A. Lavatory : Pedestal type Lavatory; AMERICAN STANDARD Under-the-counter Lavatory; Wall Hung Lavatory. Refer to plans for location. Verify with Architect or Interior Designer.
- B. Watercloset: New Elongated Cadet and New Round Front Cadet. Refer to plans for locations. Verify with Architect or Interior Designer.
- 2.2 PLUMBING FITTINGS: Unless otherwise specified, all fittings shall be American Standard in chrome finish, Sannix and Cadet Series. Refer to plans for locations. Verify with Architect or Interior Designer.
- A. Lavatory and Shower Fittings: American Standard fittings
- 2.3 PLUMBING ACCESSORIES: All toilet and shower accessories in stainless steel finish shall be Harmony accessories shall be by American Standard or Architect's approved equal. Color shall be subject to Architects approval. Plumbing accessories not included here shall be Owner supplied, Interior Designer approved, and Contractor installed.
- 2.3.1 Rollpaper Holder: Shall be Harmony manufactured by American Standard or Architect's approved equal.
- 2.3.2 Soap Holder: Shall be Harmony manufactured by American Standard or Architect's approved equal.
- 2.3.3 Towel Rails and Brackets : Shall be Harmony manufactured by American Standard,
- 2.4 SHOWER ENCLOSURE: Shall be sand-blasted glass on powder-coated aluminum frames or Architect's approved material. Shower Enclosure shall be subject to Architect's approval.
- 2.5 KITCHEN SINK: TEKA Stainless steel kitchen sink distributed by Kuysen Enterprises, Inc. or to be approved by the Architect.
- 2.6 FLOOR DRAIN: Shall be brass nickel-plated with waste and vents.
- 2.7 CABINetry: Use Narra Shelvings, Narra Panelling, Cabinet Doors shelves shall be in duco paint finish, unless otherwise indicated. Refer to I. D. Specifications. Verify with Architect.
- 2.8 COUNTERTOPS: Shall be 19mm thick cut-to-desired size CORIAN Countertop.
- 2.9 LIGHTING FIXTURES / LUMINAIRES: (Refer to I.D. Specifications)
- 2.9.1 Fluorescent Lights: (PRODUCT) warm white and cool white, 36W with diffusers, or Architect's approve equal. Submit samples of diffusers for approval. Refer to schedule of finishes.

- 2.9.2 PL and SL Lamps: Energy saving lamps shall be (PRODUCT) in warm white with diffusers. Submit samples of diffusers for approval.
- 2.9.3 PL-C Lamps: Use 13W (PRODUCT) Lamps warm white.
- 2.9.4 Exterior Lighting: Use (PRODUCT) lamps and luminaires.
- 2.9.5 Devices: (PRODUCTS), or Architect's approved equal for switches and convenience outlet plates, color and design for approval.
- 2.9.6 Diffusers: Submit Samples for Architect's approval.
- 2.9.7 Others: Bracket lights shall be pre-fabricated. Verify Plans and Details for the design. Other lighting fixtures and luminaires shall be verified with Architect and lighting consultant.
- 2.10 STAIR NOSING: (PRODUCT) *Aluminum stair nosing* as supplied/distributed by (MANUFACTURER'S NAME) or as specified by Interior Designer, as indicated in the stair details. Provide polyurethane anti-slip strips in colors approved by the Architect. Use PVC nosing where indicated on plans. Submit samples for Architect's approval.
- 2.11 BASEBOARDS: Integrated wall base *vinyl Baseboards* by (MANUFACTURER'S NAME) or as specified by the Interior Designer in colors approved by the Architect. For base use Gloss-enamel paint finish. Use polished Granite Tile for finish. Verify with Interior Designer. Refer to schedule of finishes.
- 2.12 CORNICES: Use Flushed Metal Trim for gypsum ceiling boards or as specified by Interior Designer. Provide recessed edges for cornices. Refer to schedule of finishes

END OF SECTION

DIVISION 15 MECHANICAL

SECTION 15.01 PLUMBING SYSTEM

PART 1 GENERAL

- 1.1 **SCOPE/WORK INCLUDED.** Work in this section includes furnishing all labor, materials, equipment, incidentals, procedures and supervision necessary for the installation of the plumbing system.
- 1.2 **SUBMITTALS.** The Contractor shall furnish, for approval, full Information and satisfactory evidence as to the kind and quality of materials or articles he will incorporate in the work.
- 1.3 **QUALIFICATION OF WORKMEN.** Only competent workmen, who have been thoroughly trained and experienced in the skills required and who are completely familiar with the materials involved and with the requirements of his work, shall be engaged.
- 1.4 **GENERAL REQUIREMENTS.** The project drawings shall show the general requirements as to sizes, arrangement, extent of piping, and location of equipment. Unless otherwise indicated or specified herein, all work shall be accomplished in accordance with the National Plumbing Code.

PART 2 PRODUCTS AND MATERIALS

2.1 PIPES AND FITTINGS

A. **SOIL, WASTE, AND VENT PIPES** shall be uPVC ULTIMA SUPRA SERIES manufactured by Emerald Vinyl Corporation.

1. PVC cement shall be as recommended by the PVC pipe manufacturer, solvent type

B. **COLD AND HOT WATER LINE PIPES** shall be REHAU distributed by Camp Marketing & Development, Inc.

1. Couplings and pipe fittings shall be of the heavy duty type and as recommended by the pipe manufacturer.

C. **VALVES**

1. Angle, check and glove valves shall be bronze, 125 pounds, and type as suitably for the application. Check valves shall be swing types.

2. Gate valves. All valves used for shut-off valves or gate valves shall be bronze, with screwed ends, and 125 pounds' pressure capacity.
 3. Clean-outs shall be provided in all soil, storm or waste lines at every change in direction greater than 45 degrees, size same as the pipe served. Clean-outs shall be extended to an easily accessible place or where indicated on the drawings.
 4. Pipe sleeves shall be installed and properly secured in place at all points where pipes pass through masonry or concrete, except un-framed floors on earth with sufficient diameter to provide approximately 6 mm clearance around the pipe or insulation. Pipe sleeves in walls, partitions and through floors shall be of PVC pipe, schedule 40.
 5. Pipe hangers, inserts and supports shall be provided to all horizontal runs of pipes and shall be hanged with adjustable wrought iron or malleable iron pipe hangers spaced not over 1.5 meters apart for PVC pipes and 3.0 meters apart for steel pipes. Trapeze hangers may be used in place of separate hangers on pipes running parallel to and close to each other.
 6. Shock absorbers or air capped chambers shall be provided, where shown on the drawings, on all individual branch water lines to equipment or fixtures.
- D. HOSE BIBB shall be with metal handle, heavy duty type, chrome plated, compression type, with hose threads; size shall be as indicated.
- A. FAUCETS for water system shall be SANNIX Brass Fittings shown in Chrome, manufactured by American Standard or as specified herein or as indicated shall be heavy-duty type, chrome-plated and or as specified in Section 10.01 Miscellaneous Specialties.
- B. FLOOR DRAIN shall be stainless steel with strainer, size 100 mm x 100 mm with stainless fastening screw.
- C. TOILET AND BATH FIXTURES AND ACCESSORIES shall all be American Standard as specified in Section 10.01 Miscellaneous Specialties.
1. Faucet and accessories shall be "American Standard", size and type as shown.

PART 3 INSTALLATION

- 3.1 GENERAL. Piping shall be installed according to the shop drawings, as recommended by the manufacturer and as directed during installation, straight and as direct as possible, forming right angles or parallel lines with building walls and other pipes, and neatly spaced. Erect pipe risers plumb and true, parallel with walls and other pipes neatly spaced. Before being placed in position, pipe and fittings shall be cleaned carefully. All pipes shall be maintained in a clean condition.

- 3.2 ALL PIPING shall be properly supported or suspended on stands, clamps, hangers, or equivalent of approved design. Supports shall be installed in such a manner to permit pipe free expansion and contraction while minimizing vibration. Do not install pipes in a manner that interferes with other pipes, ducts, conduits, equipment and adjacent structures of the building. The arrangement, positions and connection of pipes, fixtures, drains, valves, and the like indicated on the drawings shall be followed as closely as possible. All pipes shall be cut accurately to measurement and shall be worked into place without springing and forcing. Changes in pipes shall be made with reducing fittings. Pipes shall not pass through columns, footings, and beams, except where noted on the drawings.
- 3.3 ROUGH-IN FOR PIPES AND FITTINGS shall be carried along with the building construction. Correctly located openings of proper sizes shall be provided where required in the walls and floors for the passages of pipes. All items to be embedded in concrete shall be thoroughly cleaned and free from all rust and scale.
- 3.4 PIPES IN TRENCHES. Sewer and water piping shall be placed in separate trenches.
- 3.5 INSTALLATION OF SCREW-JOINTED PIPING. All pipes shall be cut accurately according to measurements established by the contractor and shall be worked into place without springing or forcing. Proper provision shall be made for the expansion and contraction of all pipelines. Pipe and fittings shall be free from fins and burrs. Screw joints shall be made with a lubricant applied on the male threads only; threads shall be full cut and not more than three threads on the pipe shall remain exposed. All exposed ferrous pipe threads after being installed and tested shall be given one coat of zinc chromate and enamel paint.
- 3.6 INSTALLATION OF FIXTURES. Connections between the earthenware of fixtures and the flanges on soil pipe shall be made gas and watertight. All bulk material including putty and plastics shall not be used for gaskets. Floor drains shall be secured in a water tight manner.
- 3.7 PROTECTIVE COATING FOR GALVANIZED STEEL PIPING BURIED IN THE GROUND. All galvanized steel piping buried in the ground shall be given a protective coating of zinc chromate primer and enamel paint.

PART 4 QUALITY ASSURANCE

- 4.1 TESTS. All defects disclosed by tests shall be rectified and the test repeated. All labor, materials and equipment used for tests shall be provided by the contractor.
- A. WATER PIPING. Water piping shall be subjected to a hydrostatic pressure test of 100 pounds per sq. inch. All potable water piping shall be disinfected by a mixture containing not less than 0.6 pound of high test calcium

hypochlorite, or an equivalent amount of chlorinated lime (about 2 pound), to each 1000-gallon of water, which provides not less than 50 PPM of available chlorine. The mixture shall be injected into the system shall then be drained, flushed with potable water, and placed in service.

- B. **SANITARY PIPING.** Before the installation of any fixture, the ends of the system shall be capped and all lines filled with water to the roof or 3 m above the highest fixture connections if test is done in sections or by floors and allowed to stand for at least 30 minutes without leakage. Test tees having cast iron screwed plugs shall be installed in the vertical stacks when tests are made in sections or by floors. Test within building shall be made with piping exposed. Underground piping shall be tested before backfilling.
- C. **PLUMBING SYSTEMS AND EQUIPMENT.** Plumbing system and equipment after complete installation shall be given an in service tests. All fixtures are installed the entire vent and sewer systems shall have a final test. Final test shall be either the smoke or peppermint test. Before proceeding with either test all traps shall be filled with water. Smoke test shall be accomplished by filling the entire sewer system with a pungent thick smoke produced by one or more smoke machines. When smoke appears at stack openings on the ceiling or roof, they shall be closed. A pressure equivalent to a 25 mm water column shall be exerted and maintained for 15 minutes before inspection starts. Peppermint tests shall be accomplished by introducing a minimum of 2 ounces of oil of peppermint into each stack. All stacks and line openings shall be closed during test, for a minimum period of 1/2 hour.

PART 5 GUARANTEE

The contractor shall furnish to the Owner a written guarantee covering the satisfactory operations of the plumbing installation. This shall be for a period of one year after the date of acceptance. During this period, the contractor shall repair or replace any defective work and pay for any repair or replacement cost. All damages due to improper use or caused by the Owner or his representatives/employees shall be at the Owner's expense.

END OF SECTION

DIVISION 15 MECHANICAL

SECTION 15.02 WATER SERVICE SYSTEM

PART 1 GENERAL

- 1.1 **SCOPE / WORK INCLUDED.** Work in this section includes the furnishing of all labor, materials, equipment, procedures, incidentals, and superintendence required for the installation of a water service system. Service lines shall include the pipelines from the main water distribution to the building service at a point approximately 1.5 m from the building.

PART 2 MATERIALS

- 2.1 **WATERLINE** shall be PPR - BELDEN
- 2.2 **SERVICE STOPS** shall be all bronze with flange, joint coupling and threads on inlet. Stops shall be tested to minimum hydraulic pressure of 200 pounds per square inch.
- 2.3 **SERVICE BOXES** shall be cast-iron. Extension service boxes of the required length and having either screw or slide-type adjustment shall be installed at all service box locations. The boxes shall have housings of sufficient size to completely cover the service stops and shall be complete with identifying covers.

PART 3 INSTALLATION

- 3.1 **GENERAL.** Excavation and backfilling of pipe trenches shall be as specified in Section: Earthwork.
- 3.2 **PIPE LAYING AND JOINTING.** Before being placed in position, pipe, fittings, valves, and accessories shall be cleaned, and shall be maintained in a clean condition. Proper facilities shall be provided for lowering sections of pipe into trenches. Piping that does not allow sufficient space for proper installation of jointing material shall be replaced by one proper dimension. The pipe shall be graded in straight lines, taking care to avoid the formation of any dips or low points. Pipe shall be supported at its proper elevation and grade, care being taken to secure firm and uniform support. Wood support blocking will not be permitted. The full length of each section of pipe and fittings shall rest solidly on the pipe bed, with recess's excavation to accommodate bells, joints, and couplings. Anchors and supports shall be provided where necessary and where indicated on the project drawings for fastening work into place. Proper provision shall be made for the expansion and contraction of pipelines. Trenches shall be kept free of water until joints have been properly made. Open ends of pipe at the end of each day's work shall be closed temporarily with wood blocks or bulkheads. Pipe shall not be laid when the conditions of trench or weather are unsuitable.

- 3.3 MANUFACTURER'S RECOMMENDATIONS. Where installation procedures or any part thereof is required to be in accordance with the recommendations of the manufacturer of the material being installed, printed copies of these recommendations shall be furnished to the Construction Architect/Engineer prior to installation. Installation of the item will not be allowed to proceed until the recommendations are received. Failure to furnish these recommendations can be cause for rejection of the material.

PART 4 DISINFECTION

Before acceptance for domestic operation, each unit of completed supply line and distribution system shall be disinfected, as specified below. After pressure test has been made, the unit to be disinfected shall be thoroughly flushed with water until all entrained dirt and mud has been removed before introducing the chlorinating material. The chlorinating material shall provide a dosage of not less 50 parts per million and shall be introduced into water lines in an approved manner. Treated water shall be retained in pipe long enough to destroy all non-spore-forming bacteria. Except where a shorter period is approved, retention time shall be at least 24 hours. This shall produce not less than 10 PPM of chlorine at extreme end of line - at the end of retention period. All valves on lines being disinfected shall be opened and closed several times. Samples of water shall be taken from points in the system in sterilized containers for bacterial examination. Disinfection shall be repeated until tests indicate absence of pollution for at least 2 full days. System will not be accepted until satisfactory bacteriological results have been obtained.

PART 5 QUALITY ASSURANCE

- 5.1 GENERAL. All work shall be in first class condition and constructed properly in accordance with the drawings and specifications. All defects and leaks disclosed by the test shall be corrected. Piping shall not be buried, covered, or concealed until it has been inspected, tested, and approved, except when procedure is modified by the referenced installation and testing standard.
- 5.2 FIELD TESTS. For water service line, hydrostatic pressure for pressure test shall be 50 percent in excess of the maximum working pressure of the system, but shall be not less than 100 psi and shall be held for a minimum of one hour. Prior to the pressure test, that portion of the water line being tested shall be filled with water for soaking period of not less than 24 hours. Hydrostatic pressure for leakage test for all systems shall be the maximum working pressure of the system, except as otherwise specified hereinafter. Leakage test may be performed at the same time and at the same test pressure as the pressure test.

END OF SECTION

DIVISION 16 ELECTRICAL

SECTION 16.01 ELECTRICAL WORK

PART 1 GENERAL

- 1.1 **SCOPE / WORK INCLUDED.** Work in this section covers the requirements for a complete electrical installation, including the furnishing of all labor, materials, equipment, tools, transportation, storage, incidentals and superintendence necessary to accomplish the electrical installation. The work includes, but is not necessarily limited to, the installation of interior lighting and power system. If anything has been omitted in any item of works usually furnished, which are necessary for the completion of electrical works, then such items must be included.
- 1.2 **QUALITY ASSURANCE**
- A. **REFERENCE STANDARDS.** Electrical equipment, materials and procedures shall conform to the applicable requirements of the latest edition of the following: Underwriter's Laboratories, (UL), National Fire Protection Association (NFPA), National Electrical Manufacturer's Association (NEMA) and other related publications.
 - B. **WORKMANSHIP.** All equipment and materials shall be installed in a neat and workmanlike manner.
 - C. **QUALIFICATION OF INSTALLER.** At least one licensed electrician, who has been thoroughly trained and experienced in the skills required, and who is completely familiar with the methods of installation, must be present at all times during the installation. He shall direct all work performed under this section.
- 1.3 **COMPLIANCE TO APPLICABLE CODES AND REGULATIONS.** All installation procedures, materials and equipment shall comply with the following as applicable:
- A. Philippine Electrical Code.
 - B. National Electrical Safety Code, latest edition.
 - C. Power Company Regulations.
 - D. National Fire Protection Association
 - E. Bureau of Labor Standards.
 - F. Local laws and ordinances
- 1.4 **REPAIRS TO DAMAGED EXISTING WORK.** Any damage to building, piping, or equipment caused by this work shall be repaired by skilled mechanics of the trades involved, at no additional cost to the Owner.

- 1.5 SUBMITTAL. The contractor shall submit for approval one sample of each fixture, wires and wiring devices. For circuit breakers, boxes and panel boards, catalogs or brochures may be submitted.
- 1.6 RECORD DRAWINGS. The Contractor shall keep a careful record of all the changes made in the actual installation, which differs from that shown on the Contract Drawings. Upon completion, the Contractor shall, in a neat and accurate manner, finalize "AS BUILT" drawings on tracing paper. These drawings shall be submitted to the Construction Architect/Engineer for approval. After approval, they shall become the property of the Owners. The print copies shall be duly signed and sealed by a Licensed Electrical Engineer.

PART 2 MATERIALS

- 2.1 LIGHTING FIXTURES AND LAMPS. The Contractor shall provide and install all lighting fixtures of the size and type as indicated on the drawings. All fixtures shall be wired and installed complete, including all lamps and/or tubes, transformers, ballasts, supports, brackets, canopies, globes and other parts and devices necessary for complete installation and operation.
- 2.2 FLUORESCENT FIXTURE UNIT shall be complete. The tube shall be accessible without removing the fixture. Fixture shall be direct connected to 220 volts system as shown.
- A. Ballast shall be built to the specification adopted by the certified ballasts manufacturer's approved by the Electrical Testing Laboratory with lowest sound rating with UL label. Ballasts shall be 220V rapid start high power factor series type "P" (0.95) p.f. capacitive "A" sound rating. Ballasts manufactured by (MANUFACTURER'S NAME) are acceptable.
 - B. Fluorescent tubes shall be standard cool white rapid start of wattage and quantity shown.
 - C. Fluorescent fixture housing shall be US gauge 22 sheet steel. Reflecting surfaces shall have baked white; acrylic finish preceded by one coat of baked gray primer. Acrylic shall be color stable and non-aging. Non-reflecting surfaces shall be finished with baked light gray enamel preceded by one coat of dark gray primer.
 - D. Acrylic glasses of the size and configuration shown shall be provided.
- 2.3 WIRES AND CABLES for lighting, intercom, telephone, televisions and other requirements shall be "COLUMBIA" as manufactured by "COLUMBIA Wires and Cables Corporation" or approved equivalent. Sizes and type of wires shall be as indicated, and shall pass the stringent quality requirements set by the Ministry of International Trade and Industry of Japan and the Philippine standards.

- A. All wires shall be copper, soft-drawn and annealed, shall be of ninety-eight (98%) conductivity, shall be smooth and true and of a cylindrical form and shall be within one percent (1%) of the actual size called for.
- B. Wires or cables for lighting and power systems shall be plastic insulated for 600 volt working pressure, type THW unless otherwise noted on plans or specified below. All wires AWG No. 8 and larger shall be stranded copper.
- C. Control leads for motors or lighting shall be type THW for lighting and power systems. No wire smaller than No. 12 gauge or as indicated shall be used, except for control leads.

2.4 CONDUIT for interior systems shall be uPVC V2000 Rigid Electrical conduits manufactured by Emerald Vinyl Corporation or approved by the Architect.

- A. No conduit shall be used in any system smaller than ½-inch electric trade sized, nor shall have more than four ninety degrees bends in any one run. If necessary, pull boxes shall be provided as directed.
- B. No wire shall be pulled into any conduit until the conduit system is complete in all details; in the case of concealed work, until all rough plastering or masonry has been completed; in the case of exposed work, until the conduit has been completed in every detail.
- C. The ends of all conduits shall be tightly plugged to exclude plaster, dust and moisture while the building is in the process of construction. All conduits shall be reamed to remove all burrs.
- D. All pipes and fittings on exposed work shall be secured by means of metal clips spaced a maximum of five feet which shall be held in place by means of a machine screw. When running over concrete-surfaces, the screws shall be held in place by expansion sleeves. All pipes on exposed work shall run at right angles to and parallel with the surrounding walls and shall conform to the form of the ceiling, no diagonal runs shall be allowed and all ends and offsets shall be avoided as far as possible. Where necessary, conduit fittings shall be used. Piping, in all cases shall be run perfect straight and true, satisfactory to the Construction Architect/Engineer.

2.5 OUTLET BOXES AND FITTINGS

- A. All outlets of whatever kind for all systems shall be provided with a suitable fitting which shall be either a box or other device specially designed to receive the type of fittings to be mounted thereon.
- B. The Contractor shall consult the Construction Architect/Engineer as to the nature of the various fittings to be used before installing his outlet fittings, to the nature of appliance to be a finished design.
- C. In the case of fixtures, their outlet fittings shall be provided with suitable fixture supports of a size and kind required by the fixture to be hung. Fixture

studs in general shall be 3/8 inch.

D. All outlets on exposed conduit work shall be cast alloy conduit fittings of proper type, as manufactured by (MANUFACTURER'S NAME), or approved equal.

E. At all outlets on concealed conduit work, provide galvanized pressed steel outlet boxes of standard make.

2.6 WALL SWITCHES. Wall switches shall be rated at 15 amperes, 250 volts, one-way, as required. The type of switch shall be tumbler operation and the color, plating and appearance of wall plates shall be submitted prior to the purchase of wall switches and face plates. Switches shall be as manufactured by (MANUFACTURER'S NAME), or approved equal by the Architect.

2.7 JUNCTION AND PULL BOXES. Junction and pull boxes, of code gauge steel, shall be provided for facilitating the pulling of wires and cables. Pull boxes in finished places shall be located installed with the permission and to the satisfaction of the Construction Architect/Engineer.

2.8 WALL RECEPTACLES. Receptacle outlets shall be for flush mounting duplex rated at 15 amp., 250 volts, parallel slots with grounding slot. Type and color of receptacle outlet plates shall be as selected by the Architect and appropriate samples of outlets and plates shall be submitted prior to purchase of devices.

2.9 CIRCUIT BREAKERS shall consist of a quick-make, quick break type entirely trip-free operating mechanism, with contacts arc interrupter, and thermal-magnetic trip unit for each pole, all enclosed in a molded-phenolic case. The thermal magnetic trip unit shall provide time-delayed overload protection and instantaneous short circuit protection, and in case of overload or short circuit in any one pole. Circuit breaker shall be trip indicating, with the tripped position of breaker handle midway between "ON" and "OFF" positions. Circuit breakers shall be (PRODUCT). All circuit breakers rated above 225 amperes shall have interchangeable trip units.

2.10 PANELS AND CABINETS

A. Standard panels and cabinets, as far as possible, shall be dead front construction furnished with trims for flush mounting as required. Cabinets shall be code gage steel with gutters at least 4-inch wide and wider if necessary. The trim for all panels shall be finished in gray enamel over a rust inhibitor. Panels and cabinets shall be as manufactured by (MANUFACTURER'S NAME). Manufacturer's shop drawings in triplicate shall be submitted.

B. 220- Volt lighting panels shall be equipped with 20A circuit breakers in the branch circuits and a three-pole circuit breaker in the main unless noted otherwise on plans. As indicated on plans the panels shall be assembled in two or more selection if over 20 two-pole circuits or 40 one pole circuits. Circuit breakers shall be (MANUFACTURER'S NAME).

C. Distribution panels shall be of same type as lighting panels except equipped with one-pole, two-pole and three-pole circuit breakers (PRODUCT) frame up of sizes called for on plans.

2.11 MOTOR STARTERS

A. Provide proper size, characteristics and HP rating as required by the particular motor. Use motor nameplate data for selection of overload relays. Provide an overload for each conductor.

B. Provide an enclosure for all starters. NEMA 1 for general use and the equivalent of NEMA 3R for exterior or wet or damp locations.

C. Across the line for 7-1/2 HP or less and reduced voltage type for 10 HP and larger.

2.11 GROUNDING AND BONDING EQUIPMENT. Shall be in accordance with Article 250 N. E. C. as amended by the office of the Building Official (DPWH).

2.13 GROUNDING CONDUCTORS. Non-metallic raceways, size per table 250-95 N. E. C.

PART 3 LOCATION OF WIRING AND OUTLETS

3.1 It shall be the responsibility of the Contractor to study all pertinent drawings and obtain precise information as to the exact location of all outlets, apparatus, appliances, and wiring to be installed. It shall be understood that any outlet may be relocated on a distance not exceeding 15 feet from the location shown on the drawings. Contractor shall make any necessary adjustment of his work to fit conditions for recessed fixtures and for outlets occurring in glazed tile, block, terra cotta, marble, wood paneling, or other special finish materials in order that all boxes may register flush with finish and shall be centered properly. In centering outlets, due allowance shall be made for overhead piping, ducts, window, and door trim, variations in thickness of plastering, etc., as erected, regardless of conditions which may be otherwise shown on small scale drawings. Outlets incorrectly located shall be properly relocated at the Contractor's expense. Local switches near doors shall be located at the stride side of the door.

3.2 The center of wall outlets, socket-outlets, switches, telephone outlets, pilot lights, indicating lights and clock outlets shall be installed at heights above finished floor as indicated on the drawings. Where mounting heights are indicated on the Electrical Drawings, they shall be verified with Architect's drawings before installation.

PART 4 INSTALLATION

4.1 CONDUIT INSTALLATION

A. Conduit installation shall be made with rigid metal conduit and fittings,

electrical metallic tubing, or nonmetallic conduit. Electrical metallic tubing shall not be installed underground, encased in concrete or used in outdoor work. Rigid metal conduit installed underground shall be encased in concrete or covered with a protective coating.

- B. Exposed conduit shall be installed parallel with or at right angles to the building walls and ceilings and shall be supported by pipe straps, wall brackets, hangers or ceiling trapeze. Fastenings shall be by wood screws on wood; by toggle bolts on hollow masonry units; by concrete inserts, or expansion bolts on concrete or brick; by machine screws, welded threaded studs, or spring tension clamps on steel work. Threaded studs driven in by a powder charge and provided with lock washers and nuts may be used in lieu of expansion bolts or machine or wood screws. Threaded C-clamps may be used on rigid steel conduit only. The load applied to fasteners shall not exceed 1/4 of the proof test load. Fasteners attached to concrete ceilings shall be vibration and shock resistant. Holes cut to a depth of more than 1/2 inches in reinforced concrete beams or to a depth of more than 3/4 inch in concrete joints shall not cut the main reinforcing bars. Holes not used shall be filled. In partitions of light steel construction, sheet-metal screws shall be used. In suspending-ceiling construction, conduit shall be run above the ceiling and only lighting system branch circuit raceways shall be fastened to the ceiling supports. Spring steel fasteners may be used for lighting branch circuit raceway supports in suspended ceilings in dry locations. Conduits shall be fastened to all sheet metal boxes and cabinets with two lock nuts where required by the National Electrical Code, where insulated bushings are used and where bushings cannot be brought into firm contact with the box. Locknuts shall be the type with sharp edges for digging into the wall of metal enclosures. Bushings shall be installed on the ends of all conduits and shall be of the insulating type where required by the National Electrical Code. (Exposed risers in wire shafts of multi-story buildings shall be supported by U-clamp hangers at each floor level and at intervals not to exceed 10 feet. Fittings for steel conduit and electrical metallic tubing shall be iron or steel only.)
- C. Conduit installed in concrete floor slabs shall be located so as not to affect the structural strength of the slabs. Conduit shall be installed within the middle one-third of the concrete slab except where necessary to not disturb the reinforcement. Outside diameter of conduit shall not exceed one-third of the slab thickness and conduits shall be spaced not closer than three diameters except at cabinet locations. Curved portions of bends shall not be visible above the finish slab. Slab thickness shall be increased as necessary to provide a minimum one inch cover over conduit. Where embedded conduits cross expansion joints, suitable water tight expansion fittings and bonding jumpers shall be provided. Conduit larger than one inch trade size shall be parallel with or at right angles to the main reinforcement: when at right angles to the reinforcement, the conduit shall be close to one of the supports of the slab.
- D. Conduits installed in contact with earth shall be rigid steel. Rigid steel conduits shall be encased in concrete. Zinc coating may be omitted from

steel conduit, which has a factory-applied epoxy coating. Field made joints, fittings, abrasions, imperfections shall be coated with material equivalent to the above.

- 4.2 Changes in direction or runs shall be made with symmetrical bends or cast-metal fittings. Field made bends and of offset shall be made with a hickey or conduit-bending machine. Crushed or deformed raceways shall not be installed. Trapped raceways in damp or wet locations shall be avoided. Plaster dirt or trash shall be prevented from lodging in raceways, boxes, fittings and equipment during construction. Clogged raceways shall be freed of all obstructions.

4.3 **BOXES, OUTLETS AND SUPPORT**

- A. Boxes shall be in the wiring or raceway systems wherever required for pulling of wires, making connections and mounting of devices or fixtures. Boxes shall be sheet steel. Each box shall have the volume required by the National Electrical Code for the number of conductors enclosed in the box. Boxes for mounting lighting fixtures shall be not less than 4 inches except that smaller boxes may be installed as required by fixture configuration as approved. Boxes installed for concealed wiring shall be provided with suitable extension rings or plaster covers, as required. Boxes for use in masonry block or tile walls shall be square cornered tile type, or standard boxes having square-cornered tile-type covers. Cast metal boxes installed in wet locations and boxes installed flush with the outside of exterior surfaces shall be gasketed. Separate boxes shall be provided for flush or recessed fixture when required by the fixture terminal operating temperature and fixtures shall be readily removable for access to the boxes unless ceiling access panels are provided. Boxes and pendants for surface-mounted fixtures or suspended ceilings shall be supported independently of the ceiling supports, or adequate provisions shall be made for distributing the load over the ceiling support members in an approved manner. Boxes and supports shall be fastened to wood with wood screws or screw-type nails of equal holding strength, with bolts and expansion shields on concrete or brick, with toggle bolts on hollow masonry units, and with machine screws or welded studs on steel work. Threaded studs driven in by powder charge and provided with lock washers and nuts, or nail-type nylon anchors may be used in lieu of wood screws, expansion shields, or machine screws. In open overhead spaces, cast boxes threaded to raceways need not be separately supported except where used for fixture support; cast metal boxes having threadless connectors and sheet metal boxes shall be supported directly from the building structure or by bar hangers. Where bar hangers are used, the bar shall be attached to raceway, which shall be supported with an approved type fastener not more than 24 inches from the box. Penetration into reinforced concrete members shall avoid cutting any reinforcing steel.
- B. Pull boxes of not less than the minimum size required by the Philippine Electrical Code shall be constructed of code gage galvanized sheet steel. Boxes shall be furnished with screw-fastened covers. Where several feeders through a common pull box, the feeders shall be tagged to indicate clearly the electrical characteristics, circuit number, and panel designation.

- C. Conduit stubbed up through concrete floors for connections to free standing equipment shall be provided with a short elbow and an adjustable brass tap or coupling brass or bronze threaded inside for plugs, set flush with the finished floor. Wiring shall be extended in rigid threaded conduit to equipment, except that where required, flexible conduit may be used 6 inches above the floor. Screw driver-operated threaded flush plugs shall be installed in conduit from which no equipment connections are made.
- 4.4 DEVICE PLATES OF THE ONE-PIECE TYPE shall be provided for all outlets and fittings to suit the devices installed. Plates on unfinished walls and on fittings shall be of zinc-coated sheet or cast metal having rounded or beveled edges. Plates on finished walls shall be of steel with ivory baked-enamel finish. Screws shall be of metal with countersunk heads, in a color to match the finish of the plate. Plate shall be installed with all four edges in continuous contact with finished wall surfaces without the use of mats or similar devices. Plaster filling will not be permitted. Plates shall be installed with an alignment tolerance of 1/6 inch. The use of sectional type device plates will not be permitted. Plates installed in wet locations shall be gasketed. Device plates for telephone and inter-communication outlets shall have a 3/8 inch bushed opening in center.
- 4.5 RECEPTACLES. Single and duplex receptacles shall be rated 2-pole, 3-wire grounding type, 15 amperes, and 240 volts. Body shall be ivory molded phenolic compound supported on a metal mounting strap. Receptacles shall be side and back-wired with screw type terminals. Exposed metal parts shall be corrosion resistant. The ground pole shall be connected to the mounting strap. Special purpose receptacles shall be rated as indicated.
- 4.6 TOGGLE SWITCHES shall be totally enclosed with bodies of molded compound and a mounting strap. Handles shall be ivory. Wiring terminals shall be of the screw type, back or side wired. Switches shall be rated quiet type. AC only, 15 ampere, 250 volt. Switches shall be single poles unless otherwise indicated.
- 4.7 PANELBOARDS. Lighting and appliance branch-circuit panelboards shall be circuit equipped, Type I, Class I. Circuit breakers shall be the rating, class painted.
- 4.8 GROUNDING AND BONDING. All exposed non-current-carrying metallic parts of electrical equipment, metallic raceway systems, grounding conductor and neutral conductor of wiring systems shall be grounded. The ground connection shall be made at the main service equipment and shall be made to driven rods on the exterior of the building or to the point of entrance of the metallic water service. Connections to flanged pipes shall be made to the street side of the flanged connection. No connections shall be made to water pipes coated with insulating materials.
- 4.9 RECESSED FLUORESCENT FIXTURES. Fixtures shall be installed in suspended ceiling opening as indicated. These fixtures shall have adjustable

fittings to permit alignment with ceiling panels. Fixtures installed in fire-resistant type of suspended ceiling construction shall be provided with fireproofing boxes having materials of the same fire rating as the ceiling panels, in conformance with the Building Materials List of Underwriter's Laboratories, Inc.

4.10 FLEXIBLE CONNECTIONS of the short length shall be provided for equipment subject to vibration, noise transmission, or movement and for all motors. Liquid-tight flexible connections shall be provided as required.

4.11 EQUIPMENT CONNECTIONS. All wiring for the connection of motors and control equipment shall be furnished and installed under this section of the specification, except as otherwise specifically noted or specified. Automatic-control wiring, signaling, and protective devices are not included in this section, but shall be furnished and installed under other sections of the specifications. Control wiring not shown on the electrical drawings shall be furnished.

PART 5 TESTS

5.1 All wiring shall be tested for circuit continuity to assure that the wiring system is free of short circuit, accidental grounding or other defects prior to normal system operation. Tests shall be performed after all wiring is completed, and again after fixtures and equipment are connected and ready for use.

5.2 After the Contractor has assured himself that the wiring systems are free of faults, the Contractor shall then energize the systems from their normal power sources and confirm that all systems are operational as required by the contract documents, prior to final inspection.

END OF SECTION

Design Parameters

DSWD-FOX

ARCHITECTURAL DESIGN PARAMETERS

□ □ CODES AND STANDARDS

The Architectural Works shall be in accordance with the following Laws, Codes and Standards.

1.0 LAWS AND CODES

- 1.1 PD 1096 or National Building Code of the Philippines and its Latest and Amended IRR
- 1.2 RA 9266 or The Architecture Act of 2004 and its Latest and Amended IRR
- 1.3 BP 344 or Accessibility Law and its Latest and Amended IRR
- 1.3 RA 9514 or Fire Code of the Philippines and its Latest and Amended IRR
- 1.5 Existing Local Codes and Ordinances

2.0 STANDARDS

- 2.1 International Standards Organization ISO 9001:2008 – Quality Management
- 2.2 United States Green Building Council LEED Sustainable Design certification
- 2.3 Integrated Resilient Design Program sponsored by the Science and Technology Directorate of the US Department of Homeland Security.

3.0 SUSTAINABLE ARCHITECTURAL CONCEPTS

- 3.1 Green building design character and concepts
- 3.2 Sustainable Architectural conceptual flow

□ □ GENERAL DRAWING GUIDELINES

1.0 GENERAL

- 1.1 All drawings shall be computer drafted. Drawings shall be submitted both in printed and electronic copies.
- 1.2 Keep the same orientation for all plans. The north orientation shall be indicated in all architectural plans. The orientation of the architectural plans shall be consistent with all the engineering plans.
- 1.4 Existing buildings and new works shall be clearly indicated and labeled in site plans.

- 1.3 Detailed plans shall have a scale not smaller than 1:50 meters.
- 1.5 Spot detailed plans, elevations and sections shall have a scale not smaller than 1:20 meters.
- 1.6 Avoid notes such as “see architectural detail” or “see structural”. Always refer with a callout to the specific detail drawing and sheet number.

2.0 SITE PLANS

The site plans shall have a scale not smaller than 1:200 meters.

3.0 FLOOR PLANS

- 3.1 All plans shall be 1:100 meters. The same scale shall be used for the rest of the architectural, structural, sanitary, plumbing, electrical and mechanical plans, except for each trade’s site plan, detailed plans and spot details.
- 3.2 Elevation callouts shall be indicated on the floor plans and shall be consistent with the elevation drawing.
- 3.3 Section line callouts on the floor plans shall be consistent with the section drawing.
- 3.4 Floor plans shall be indicated with boxed room callout numbers, including the callout for floor finishes and wall finishes.
- 3.5 Floor elevations shall be indicated in the floor plans. This shall be in reference to the natural grade line or the established finished floor lines of the adjoining existing buildings.
- 3.6 The location of mechanical equipment, e.g. air conditioning shall be indicated in the floor plans. This shall be consistent with the mechanical and electrical plans.
- 3.7 Door callouts shall be circles with proper numbering,
- 3.8 Window callouts shall be hexagons with the proper numbering,

4.0 ELEVATIONS AND SECTIONS

- 4.1 Finish floor lines and top of truss lines shall be consistent in all the elevations, sections and structural plans and details.
- 4.2 Floor-to-floor heights shall consider beam depths, mechanical ducting, cable trays and plumbing space above the ceiling, and optimum ceiling heights. Floor-to-floor heights shall not be less than the values indicated on the Schematic **Plans**.

5.0 REFLECTED CEILING PLANS

- 5.1 Reflected ceiling plans shall be indicated with boxed room callout numbers, including the callout for ceiling finishes and lighting fixtures.
- 5.2 Ceiling height relative and in reference to the finish floor line shall be indicated in the reflected ceiling plans in each rooms with boxed dimensions. This is to ensure that the ceiling heights of all rooms are established whether or not reflected in the sections.
- 5.3 The description and location of the fixtures, e.g. lighting, smoke detectors, air condition vents, exhaust fans, in the reflected ceiling plans shall be consistent with the electrical and mechanical plans.

6.0 ROOF PLANS

Location of all downspouts shall be indicated in the roof plans.

7.0 DOORS AND WINDOWS

Door and window schedules shall indicate the type of door or window, the number of doors and windows, the location/s of the door or window, the materials and accessories included and other special specifications, e.g. color or finish.

8.0 DETAILS

- 8.1 Provide a minimum of one (1) section of a scale not smaller than 1:50 meters for each area preferably cut along the area with special construction design.
- 8.2 Provide spot detail plans, elevations and sections of a scale not smaller than 1:10 meters for special designs with aesthetic treatment and ornamentation.
- 8.3 Provide detail plan of a scale not smaller than 1:50 meters for all areas needing tile pattern, e.g. dwelling units, toilets, corridors, stairs, lobby, common areas, entrance walk, showing the position and pattern of tiles.
- 8.4 Centerline location of plumbing fixtures shall be indicated in detail plan with lines of reference and its corresponding dimensions. This is to indicate the exact locations of the plumbing/sanitary roughing-ins.

9.0 COORDINATION DRAWINGS

- 9.1 During design development only, provide colored coordination floor plans and reflected ceiling plans that show the overlays of all relevant disciplines. The scale should not be less than 1:100 meters, with each professional assigned a unique color. A legend identifying the discipline and line or object colors shall be contained in each sheet.
- 9.2 Responses to reviewer comments shall be noted in the forms supplied by the Construction Manager. Approval to proceed with Construction Documents

(For Construction) shall be confirmed after designer's responses to reviewer comments on the coordination drawings have been accepted.

- 9.3 Responses to reviewer's comments on Design Development documents shall be back-checked in the Construction Documents prior to implementation.

10.0 DRAWING QUALITY CONTROL

All drawings and specifications shall be signed and sealed by the licensed professional who performs quality control prior to submission of Design Development and For Construction deliverables.

C. SITE WORKS

The Master Site Development Plan shall include the following:

1. Contour and survey of the lot, including bearing and dimensions of the property lines.
2. Road network, curbs and gutters, and sidewalks.
3. Parking spaces
4. Reference location of existing trees, swales and waterways
5. Reference location and footprint of proposed and existing buildings, with the corresponding building names and dimensions, including distances between adjacent buildings, and distances between buildings and the nearest property lines
6. Reference location of utilities, e.g., water reservoirs, septic tanks, water treatment plant, powerhouse, transformers, waste storage area, security outposts.
7. A porte-cochere shall be provided at the main entrance of the building. Where required, covered walkways shall be provided for access and connection to other buildings.
8. Ramps shall be provided in all main entrances of the buildings and other access opening to walkways leading to other buildings.

D. BUILDING ARCHITECTURAL WORKS

1.0 FLOOR PLANS

- 1.1 The structural, sanitary, plumbing, electrical and mechanical designs are required to refer to the architectural plans and specifications in case of discrepancies. If an engineering design will have any possible conflict or

interference on the architectural design, the latter may be adjusted provided that the aesthetic value will not be compromised.

- 1.2 The architectural and engineering plans shall be consistent all throughout in terms of dimensions and locations of columns, beams, walls, roof line, conduits, ducts, pipes and fixtures, among others. Column and beam grid lines shall be consistent in all the architectural and engineering plans.
- 1.3 Verify and coordinate floor plans with the mechanical, electrical and sanitary design with regard to the requirements for mechanical rooms, AHU rooms, pipe chase, and other engineering requirements.
- 1.4 Public toilets shall have provisions and fixtures for persons with disability as required by BP 344. If enough space allows, toilets specially made and designed for persons with disability is preferable.

2.0 WALLS

- 2.1 Exterior concrete walls shall be 200mm thick, while interior concrete walls shall be 150mm thick. This is indicative of the finished wall thickness including the plastering and tile works.
- 2.2 Toilet wall tiles shall be at least 600mm x 600mm, unless otherwise specified. Toilet wall dimensions shall be based on the modular sizing of tiles to avoid tile serujo and or excessive tile wastage.
- 2.3 Layout and work on wall and floor tiles must be aligned, plumb, level and square.
- 2.4 All edges, corners and intersections of toilet tiles, including the top most tiles not reaching the ceiling shall be provided with polyvinyl chloride tile trims.
- 2.5 Tile color and design shall be approved first before installation.

3.0 FLOORS

- 3.1 If floor tiles in two adjacent areas with different material, color or design meet at the door opening, the cut shall be located middle of the door thickness when in a closed position. Provide details in the floor pattern designs. Provide aluminum threshold, when required.
- 3.2 Floors at the openings of toilets for persons with disability shall be sloping. Indicate in the plans and sections.
- 3.3 Toilet floor tiles shall be at least 600mm x 600mm, unless otherwise specified. Toilet dimensions shall be based on the modular sizing of tiles to avoid tile serujo and or excessive tile wastage.
- 3.4 Pantry and kitchen floor tiles shall be at least 600mm x 600mm, unless otherwise specified. Kitchen dimensions shall be based on the modular sizing of tiles to avoid tile serujo and or excessive tile wastage.

- 3.5 Lobby and corridor floor tiles shall be 600mm x 600mm, unless otherwise specified.
 - 3.6 Layout and work on wall and floor tiles must be aligned, plumb, level and square.
 - 3.7 All edges, corners and intersections of toilet tiles, shall be provided with polyvinyl chloride tile trims.
 - 3.8 Tile color and design shall be approved first before installation.
- 3.8 Use flooring for basketball courts standard for pro basketball events.

4.0 CEILING WORKS

- 4.1 Ceiling height in corridors should be planned to avoid conflicts between ductwork for exhaust, cable trays and plumbing. Determination of slab to slab height should consider beam depth which would limit the locations where room air supply and exhaust may run across.
- 4.2 Soffit of exterior beams and slabs shall have drip molds to prevent damage due to water seeping into the eaves or ceiling. Section details shall be required to show the drip mold.
- 4.3 The direction of lighting fixtures shall be consistent in all building rooms with exterior windows.

5.0 DOORS AND WINDOWS

- 5.1 All entrance doors to offices and laboratories shall be frameless glass doors.
- 5.2 Major entry ways that require security shall be installed with security access systems as required.
- 5.3 Wall partitions facing or along the corridors shall be frameless glass partitions.
- 5.4 Toilets and other wet areas shall have steel doors on steel frames.
- 5.5 Fire escape doors should be provided with panic hardware and door closers and shall conform to the requirements of the Fire Code of the Philippines.
- 5.6 Aluminum frames of glass doors shall be powder-coated.
- 5.7 Door finish and color shall be approved first before application.

- 5.8 Window sills shall be slightly sloped outwards to prevent damage to windows and paint due to water seepage. Section details shall be required to show this slope.
- 5.9 Door jambs with no moulding/casing installed on concrete walls shall have construction grooves all around. Provide details.
- 5.10 All doors and windows shall have reinforced concrete lintel beams. Provide details.
- 5.11 Laboratory doors and windows in high containment and barrier areas shall have stainless steel frames and sealable openings. Seals and room integrity will be subjected to testing

6.0 STAIRS, RAMPS AND CORRIDORS

- 6.1 Ramps for persons with disability shall have a slope not higher than 1:12. Handrails and clearances shall conform with the requirements of BP 344.
- 6.2 Regular stairs shall have risers at 150mm high and treads at 300mm wide. Handrails shall be at least 900mm high. Clearances shall conform to the requirements of the Fire Code of the Philippines.
- 6.3 Corridors shall have a minimum unobstructed width of 1500mm. This shall be measured clear from the surface of the finished wall and not on-center of the rough CHB wall.
- 6.4 Corridors and exit doors shall conform to the requirements of the Fire Code of the Philippines.

7.0 FIXTURES AND ACCESSORIES

- 7.1 Electrical light switches shall be located by the knob side of the door.
- 7.2 Electrical light switches and outlets shall be installed plumb and level.
- 7.3 The back boxes of receptacles and switches shall be packed with expanding sealant prior to installation. The outside edges and screws on face plates or trims shall be sealed and wiped clean of excess sealant.

8.0 ROOFING WORKS

- 8.1 The section of the concrete roof gutters shall be designed, in case of a clogged downspout, so that the overflow of water will be directed outside of the building and not towards the eaves or interior ceiling to prevent any damage. Provide membrane-type and integral-type waterproofing. Provide details.
- 8.2 Avoid valley or inside gutters in roof design. But in cases required in aesthetic design, valley or inside gutters shall be in stainless steel or concrete

gutters with membrane-type waterproofing, and the section shall be designed with a capacity for big volume to prevent any damage due to overflow. Provide details.

- 8.3 Parapets, designed as a roof protection from the winds, must be designed to satisfy the preceding parameters. Provide details.
- 8.4 Concrete roofs shall be provided with membrane-type and integral-type waterproofing. Where roof space is to be developed into a roof deck garden, the proper drainage, insulation, waterproofing, vapor/thermal barriers and irrigation system shall be put in place. Provide details and mock-ups for approval prior to installation.
- 8.5 The slope of a hipped roof shall not be less than 14 degrees.

9.0 PAINTING

- 9.1 Painted ceiling shall be in flat latex finish, while cornices and mouldings shall be in gloss enamel finish unless otherwise noted.
- 9.2 Painted interior wall shall be at least in semi-gloss latex finish for rooms, unless specified to a higher type of paint.
- 9.3 Paint in special rooms for containment or barrier areas shall be epoxy system.
- 9.4 Painted exterior wall shall be at least in moisture-resistant/water-repellant solvent-based paint finish, textured or smooth, unless otherwise specified.
- 9.5 Paint color and shade shall be approved first before application.

E. SPECIFIC REQUIREMENTS

Provide spot detail plan and sections of the following:

- 1. Lattice work details (if any)
- 2. Gutter, eaves, and parapet
- 3. Ceiling – cove light (if provided), special connections and design, moldings, valances
- 4. Doors, windows, and gates – grille works
- 5. Special Architectural Treatment and Design, e.g. façade design, special windows and doors
- 6. Special Carpentry Works, e.g. partitions, cabinetry

7. Other details as may be required

F. SUMMARY OF MATERIALS

1. Materials to be used shall be fire-resistant, non-toxic, moisture-resistant and termite-resistant, e.g. fiber cement board, light-gauge steel frame, polyvinyl chloride ceiling panels.
2. Wet areas, e.g. toilets, and kitchen shall use non-skid/non-slip granite or vitrified ceramic floor tiles.
3. Heavy traffic areas, e.g. lobby, and corridor shall use heavy-duty seamless granite floor tiles or a higher type of floor material.
4. Ramps and stairs shall use non-skid/non-slip floor tiles, materials as specified.
5. Aluminum framings for glass works shall be powder coated.
6. Metal rod hangers with adjustable clips, and not galvanized iron wires, shall be used to support and suspend the aluminum T-runners and light gauge metal furring.
7. Roofing sheets shall be Ga. # 24 aluminum-coated, with embedded insulation, pre-formed and long-span.

G. DRAWING REQUIREMENT

CIVIL/STRUCTURAL DESIGN PARAMETERS

A. CODES AND STANDARDS

The Civil/Structural Design shall be in accordance with the following Laws, Codes and Standards.

1.0 LAWS AND CODES

- 1.1 National Structural Code of the Philippines (NSCP) 2010
- 1.2 PD 1096 or National Building Code of the Philippines and its Latest and Amended IRR
- 1.3 BP 344 or Accessibility Law and its Latest and Amended IRR
- 1.4 Existing Local Codes and Ordinances

2.0 STANDARDS

- 2.1 Bureau of Product Standards (BPS)
- 2.2 Philippine National Standards (PNS)
- 2.3 DPWH Blue Book
- 2.4 American Concrete Institute (ACI)
- 2.5 American Society for Testing Materials (ASTM)
- 2.6 American Welding Society (AWS)

□ □ SITE WORKS

1.0 GENERAL

Based on the Master Site Development Plan, provide where applicable complete design and details of road (concrete with curb gutter, including drainage) network, walkways parking areas and fencing.

1. The main driveway leading to the main entrance of the building shall be capable of two-lane traffic (at least 6.00 meters wide) with a minimum thickness of 150mm (8 inches). The perimeter road shall be capable of one way traffic. Concrete strength should be at least 3000psi. Roads shall be so designed to accommodate delivery vehicles.
2. Walkway should be at least 100mm thick with concrete strength of 2500psi. Ramps should be provided, instead of steps, for any change in elevations.
3. Parking area slabs should be at least 150mm thick with concrete strength of 3000psi.

C. BUILDINGS

1. The buildings should be designed using seismic importance factor of 1.25 for immediate occupancy category. Buildings should be designed in accordance with NSCP requirements up to magnitude 7 for those near seismic source Type A. Seismic gaps between buildings (old and new) should be properly observed.
2. The buildings should be designed also using wind importance factor of 1.15 (especially for design of trusses/roofing system). Concrete gutters and parapet walls should be provided as additional protection to the roofing system during strong typhoons.
3. The structural designer should verify with Philippine Volcanology and Seismology (PHIVOLCS) the distance of the proposed building to the nearest active fault lines and with the DENR for geo-hazard mapping.

4. The structural designer shall confirm the required fire ratings for building components based on the laboratory occupancy and design structural elements accordingly. Materials that have low or no volatile organic compounds should be used.
5. The structural designer is encouraged to use fire-resistive and non-toxic materials.
6. Geotechnical investigation or soil tests have been conducted on site to determine soil bearing capacity and recommended foundation design. The structural designer shall study the results and recommendations of these tests and take such into consideration in designing the appropriate foundation system for the building.

D. SPECIFIC REQUIREMENTS

The following shall be provided:

1. Connection details of beam and columns following the requirements of NSCP on confined areas.
2. Connection of trusses to beams and columns.
3. Splicing details of reinforcing bars on columns and beams and the required bar cut-off points.

E. SUMMARY OF MATERIALS

1. Concrete shall be Portland cement and conforming to ASTM Specification C150, Type I to Type II.
2. Coarse Aggregates shall consist of washed gravel, crushed stone or rock or a combination thereof conforming to ASTM C33.
3. Concrete hollow blocks shall be a standard product of recognized manufacturer conforming to PNS 16 with at least 350psi strength.
4. Reinforcing bars shall conform with PNS Grade 60 for 16mm diameter and above and PNS Grade 40 for 12mm diameter and below.
5. Structural steel shall conform with ASTM A36.
6. Bolts and studs shall conform with ASTM A325.
7. Welding electrodes shall be E60 or E70 and conform with AWS D.1.1.

F. DRAWING REQUIREMENTS

SANITARY/PLUMBING DESIGN PARAMETERS

A. CODES AND STANDARDS

The Sanitary/Plumbing Design shall be in accordance with the following Laws, Codes and Standards.

1.0 LAWS AND CODES

- 1.1 National Plumbing Code of the Philippines (NPCP)
- 1.2 Sanitation Code of the Philippines.
- 1.3 PD 1096 or National Building Code of the Philippines and its Latest and Amended IRR
- 1.4 RA 9514 or Fire Code of the Philippines and its Latest and Amended IRR
- 1.5 Existing Local Codes and Ordinances

2.0 STANDARDS

- 2.1 Bureau of Product Standards (BPS)
- 2.2 Philippine National Standards for Drinking Water
- 2.3 Underwriters Laboratory (UL)
- 2.4 National Water Resources Board (NWRB)
- 2.5 National Plumbers Association of the Philippines (NAMPAP)
- 2.6 Philippines Society of Sanitary Engineers, Inc. (PSSE)

B. SITE WORKS

1.0 GENERAL

Based on the Master Site Development Plan, the Site Works shall provide complete layout of the following:

1. Storm Drainage Network, indicating Drainage Manholes and Pipe Culverts;
2. Sewerage Pipe Network, indicating Sewage Manholes, Sewage Pipes and the location of the proposed Sewage Treatment Plant;
3. Water Supply Network, indicating the location of Water Service entrance, Cisterns, Elevated Water Tank and proposed Pump House.

- a. The Storm Drainage Network shall accommodate the magnitude of peak rates of surface run-off including drainage coming from the buildings. The system shall be capable of handling the design flows routing to the designated outfall. For rainfall calculation and sizing of drainage pipes, refer to Table-D2, Appendix-D, National Plumbing Code of the Philippines and current rainfall record from PAG-ASA (250mm/hr).
- b. The Sewerage Pipe Network design shall accommodate all sewage coming from all the facilities, conveyed by gravitational flow leading to the proposed or existing Sewage Treatment Plant./
- c. The Water Supply Network shall include the provision of Fire Hydrants, accessible Drinking Fountain that will serve as testing point for safe and potable water supply.

C. BUILDING FACILITIES SANITARY/PLUMBING SYSTEM

1.0 SEWER LINE AND VENT SYSTEM

Provide complete Sewer Line and Vent System from all plumbing fixtures and floor drains, laid by gravity flow leading to the Sewage Treatment Plant (STP). For Demand Weight of Fixtures in Fixture Units, refer to Appendix-A, Table A-2, NPCP.

2.0 WASTEWATER LINE AND VENT SYSTEM

- 2.1 For all wash areas dealing and generating with oil/grease, provide separate Waste Line and Vent System and solely tap to the proposed Grease Trap and then connect its effluent to the Sewage Treatment Plant. For Estimated Demand Weight of Fixtures in Fixture Units, refer to Appendix A, Table A-2, NPCP.
- 2.2 Laboratory effluent when hazardous should be treated prior to entry into the public sewer.

3.0 WATER LINE SYSTEM

- 3.1 Provide complete cold water supply pipes to all plumbing fixtures. Form the main water source, the water shall be pumped to the Elevated Water Tank (EWT) and conveyed to the fixtures by gravity system and or distributed to fixtures by transfer pumped with constant pressure through a Pneumatic Storage Tank, whichever is feasible.
- 3.2 Provide complete hot water system with portable water heaters for selected areas as required and or specified by the Owner.

4.0 STORM DRAINAGE SYSTEM

- 4.1 Provide complete storm drainage system for all roofs, canopies, concrete ledges and balconies including condensate drains laid for gravity flow connected to a leader/pipe line leading to the natural ground level storm drainage network.
- 4.2 Provide option to harvest storm water for landscape irrigation or use in toilet through a grey water system.

5.0 FLOOR DRAINS

- 5.1 Provide floor drains in laboratories that have deep traps that can be filled less frequently to avoid odors for backing up into the laboratories.
- 5.2 Provide floor drains as needed to conveniently capture condensate from equipment such as ice makers, controlled environment rooms, steam sterilizers, glassware washers.

D. SPECIFIC REQUIREMENTS

Provide details of the following:

1. Grease Trap

E. SUMMARY OF MATERIALS

1. Sewer and vent pipes: un-plasticized Polyvinyl Chloride (uPVC) extra series 1000 conforming to ISO 3633 ASTM D2729 including trims and fittings
2. Storm drainage pipes: downspouts, un-plasticized Polyvinyl Chloride (uPVC) extra series 1000 conforming to ISO 3633 ASTM D2729 including trims and fittings (BPS Certified)

F. DRAWING REQUIREMENTS

MECHANICAL DESIGN PARAMETERS

A. CODES AND STANDARDS

The Mechanical Design shall be in accordance with the following Laws, Codes and Standards.

- 1.0 LAWS AND CODES
 - 1.1 Mechanical Engineering Code of the Philippines
 - 1.2 Sanitation Code of the Philippines

- 1.3 PD 1096 or National Building Code of the Philippines and its Latest and Amended IRR
- 1.4 RA 9514 or Fire Code of the Philippines and its Latest and Amended IRR
- 1.5 Existing Local Codes and Ordinances

2.0 STANDARDS

- 2.1 Bureau of Product Standards (BPS)
- 2.2 Philippine National Standards (PNS)
- 2.3 Underwriters Laboratory (UL) and Factory Mutual (FM)
- 2.4 International Electro-technical Commission (IEC) 1988
- 2.5 National Fire Protection Association (NFPA)

B. BUILDING VENTILATION

1. Provide natural flow concepts

C. SPECIFIC REQUIREMENTS

1. Section of wall partition at double door autoclave and canopy hood.
2. Section of wall partition at door of rack and cage wash equipment.
3. Relative room pressurization design for BSL-3, ABSL-2 and ABSL-3 spaces.
4. Schedule of air handling equipment and electrical requirements for coordination.
5. Energy saving measures designed to decrease relative energy consumption.
6. Passive measures for providing indoor air comfort and monitoring indoor air quality.

D. DRAWING REQUIREMENTS ELECTRICAL DESIGN PARAMETERS

A. CODES AND STANDARDS

The Electrical Design shall be in accordance with the following Laws, Codes and Standards.

- 1.0 LAWS AND CODES
 - 1.1 Philippine Electrical Code

- 1.2 National Electrical Code
- 1.3 PD 1096 or National Building Code of the Philippines and its Latest and Amended IRR
- 1.4 RA 9514 or Fire Code of the Philippines and its Latest and Amended IRR
- 1.5 Existing Local Codes and Ordinances
- 2.0 STANDARDS
 - 2.1 Bureau of Product Standards (BPS)
 - 2.2 Underwriters Laboratory (UL)
 - 2.3 National Fire Protection Association (NFPA)
 - 2.4 International Electro-technical Commission (IEC)
 - 2.5 Illumination Engineering Society (IES)
 - 2.6 National Electrical Manufacturer's Association (NEMA)
 - 2.7 United States Green Building Council LEED Sustainable Design certification
 - 2.8 Integrated Resilient Design Program sponsored by the Science and Technology Directorate of the US Department of Homeland Security.

B. SITE WORKS

Based on the Master Site Development, the Site Works shall provide complete Electrical layout of the following:

1. KVA rating and other specifications of Transformer
2. Switchgear requirements
3. Panel board Layout
4. Electrical Metering Devices
5. Service Conductors and Conduit Layout
6. Grounding System
7. Emergency Standby Generators
8. Street and Perimeter Lighting System

9. Laboratory electrical panels and circuit breakers for laboratory equipment
10. Life safety features of electrical system in laboratories and auditorium
11. Lighting calculations for offices, laboratories, meeting rooms and auditorium
12. Energy saving measures to decrease relative energy consumption

C. BUILDING FACILITIES ELECTRICAL SYSTEM

1.0 LIGHTING SYSTEM

- 1.1 Provide and install adequate normal branch circuits for Lighting Systems to all areas using the standard Lighting Design Analysis. Utilize the standard illumination requirements per area of concern using the preferred particular type of luminaires.
21. Provide LED lights for all areas, unless otherwise specified.

2.0 POWER SYSTEM

- 2.1 Provide and install adequate normal branch circuits for the Power System.

3.0 STANDBY/EMERGENCY SYSTEM

- 3.1 Provide and install adequate life safety and critical emergency branch circuits for lighting or utilization equipment connected to the alternate power source.

D. SPECIFIC REQUIREMENTS

Provide details of the following:

1. Lighting Fixtures/Luminaries
2. Panel board and Circuit Breakers
3. Switchgear and other Metering Devices
4. Electrical Equipment and other Special Equipment
5. Installation and Termination of Auxiliary and other Special Devices and Equipment
6. Power and Telephone Hand holes (as may be required)
7. Pedestal and Service Entrance to building

8. Grounding System Layout
9. Others as may be required

E. SUMMARY OF MATERIALS

1.0 GENERAL LIGHTING LUMINAIRES

1.1 Fixtures type shall be as indicated on the Lighting Layout Plan:

- a. LED lights shall be wall or ceiling mounted or recessed luminaires.
- b. LED fixture housing shall be copper-free aluminum with epoxy powder coat paint finish and the lens material shall be heat and impact-resistant glass or polycarbonate.
- c. Other special lighting requirements shall be as approved by the LGU.
- d. Adjust lighting design so that laboratory benches are provided with more light than office desks. Confirm that the LED lights used for calculations are the same as specified and approved for installation.
- e. Day lighting and indoor lighting should provide a consistent (high) level of light at laboratory benches without shadows.

2.0 WIRING DEVICES

Wiring devices shall be non-automatic control devices, the contact is guaranteed by the pressure of the special spiral springs.

- 2.1 Switches shall be of 15A, 250V or 300V except as otherwise noted and approved. Terminals shall be screw-type or quick-connected type.
- 2.2 General use receptacle shall be 15A, 240V grounding type unless otherwise indicated on the drawings.
- 2.3 Special purpose receptacles shall be as called for on the drawings or required by laboratory equipment. Matching plugs shall be supplied. The End user's equipment list shall determine locations of special purpose receptacles.

3.0 PANELBOARDS AND CIRCUIT BREAKERS

The Panel Board and Circuit Breakers shall be equipped with molded-case circuit breakers and shall be the type as indicated in the panel board schedule and details.

- 3.1 Provide molded-case circuit breakers of frame, trip rating and interrupting capacity as shown on the drawings. The circuit breakers shall be quick-make, quick break, thermal-magnetic, trip-indicating and shall have common trip on all multiple breakers with internal trip mechanism.
 - 3.2 All current-carrying parts of the panel boards shall be plated. Provide solid neutral (S/N) assembly when required. The assembly shall be isolated from the enclosure.
 - 3.3 Panel boards serving laboratories should be near the door of the lab for access by staff.
 - 3.4 Circuit breakers for large equipment set-ups may be added in future so sizing of electrical equipment should be based on a fully occupied laboratory building.
 - 3.5 Provide laboratory equipment with dedicated circuit breakers as required by manufacturer's in the site facility preparation guides.
 - 3.6 Surface mounted raceways shall have a duplex receptacle spaced every 600 mm and circuit breakers shall be mounted on or at the raceways for safe shut-off during emergencies.
 - 3.7 GFI receptacles shall be used near wet areas per code.
 - 3.8 All receptacles shall be commercial grade with brushed metal face plates.
 - 3.9 All receptacles shall have labels or tags identifying the panel and circuit number as shown on the electrical power plans.
 - 3.10 All electric outlets shall be color-coded, i.e. metallic grey or approved color for outlets connected to emergency power source/ back-up generator.
- 4.0 ELECTRICAL CONDUITS, BOXES AND FITTING.
- 4.1 All conduits, boxes and fittings shall be standard rigid steel, zinc coated or galvanized.
 - a. Rigid Steel Conduits (RSC)
 - b. Rigid Metal Conduits (RMC)
 - c. Intermediate Metal Conduits (IMC)
 - d. Electrical Metallic Tubing (EMT)
 - e. Un-plasticized Poly-Vinyl Chloride (uPVC) if required shall be Schedule 40.

5.0 CONDUCTORS

5.1 Wires and cables shall be of the approved type and unless specified or indicated otherwise, all power and lighting conductors shall be insulated for 600 volts.

5.2 The conductors used in the wiring system shall be of soft-annealed copper having a conductivity of not less than 98% of that of pure copper and insulated for 60°C temperature.

5.3 All conduits of convenience outlets and wire ways for lighting branch circuit homeruns shall be wired with a minimum of 3.5mm square in size.

DSWD-FOX

*Section VI. Performance Specifications and
Parameters*

DSWD-FOX

GENERAL

LOT 1: CONSTRUCTION OF ECUMENICAL CHAPEL (DESIGN & BUILD)

I- GENERAL

1. INTRODUCTION

This project undertaking is aimed for the complete design and construction of the ECUMENICAL CHAPEL at Regional Rehabilitation Center for Youth (RRCY), BRGY. KAHULOGAN, GINOGOOG CITY and its appurtenant structures at the DSWD FO-X COMPLEX, with the objective of producing a prime facility with the quality and character of environment appropriate to the aims of the DSWD FO-X. The resulting building should possess the quality and character needed to meet higher quality facilities with standards, complying the National Building Code regulations and Fire Safety Standards of the Fire Code of the Philippines and at the same time meeting the requirements for sustainable design providing green features of design like allowing natural air circulation, energy conscious designs, maximum utilization of day lighting, employing plants as part of the integrated building design for natural air pollution filter and carbon removal and improving the indoor and outdoor air quality of the building and conservation of water use through rain collection and utilization.

2. OBJECTIVES

DSWD FO-X wishes to engage the services of a qualified Design/Build Firm to prepare the detailed architectural and engineering design plans as well as undertake the construction of the proposed **ECUMENICAL FACILITY**. The objectives of this **PERFORMANCE SPECIFICATIONS AND PARAMETERS** herein referred to as **TOR** are as follows:

- 2.1 To provide the **Designer/Builder** with the background information regarding the preparation and submittal of the proposal;
- 2.2 To provide the **Designer/Builder** with the background information regarding the proposed project which should be handled in the shortest possible time, at the lowest possible cost and at an acceptable quality and performance;

3. ROLE OF THE DESIGNER/BUILDER

- 3.1 The **Designer/Builder**, for which this **PERFORMANCE SPECIFICATIONS AND PARAMETERS** applies, shall provide technical services in the preparation of the detailed Architectural and Engineering design for the proposed **ECUMENICAL FACILITY** building within the viable cost range and established design level. The design services shall be carried out in accordance with the **DSWD FO-X** and approved *Design Guidelines, Criteria and Facilities Standards*.

In this regard, the **Designer/Builder** or the key personnel to be assigned to the project must have adequate professional experience compatible with the undertaking.

- 3.2 The **Designer/Builder** shall also implement the construction activities to complete the project in accordance with the approved construction drawings and specifications and the scope of work as specified in the contract. **The Designer/Builder** shall carry out the construction activities under the supervision of the assigned **DSWD FO-X Technical Inspectors** qualified technical staff.
- 3.3 The **Designer/Builder** shall complete the services or “**Work**” within ONE HUNDRED TWENTY DAYS (120) calendar days scheduled as follows:
 - 3.3.1 Detailed Design Phase including review by **DSWD FO-X Technical Inspectors** technical staff should be completed within fifteen (15) calendar days.
 - 3.3.2 Construction Phase should be completed within ONE HUNDRED TWENTY (120) calendar days.

4. EXTENT OF THE PROJECT

Scope of Work/Project Description

Design and Build of the ECUMENICAL FACILITY design concepts are as indicated in the conceptual plans. The works consist of the following:

This project undertaking is aimed for the complete design and construction of the ECUMENICAL CHAPEL at RRCY COMPLEX with the objective of producing a prime facility with the quality and character of environment appropriate to the aims of the DSWD FO-X. The resulting building should possess the quality and character needed to meet higher quality facilities with standards, complying the National Building Code regulations and Fire Safety Standards of the Fire Code of the Philippines and at the same time meeting the requirements for sustainable design providing green features of design like allowing natural air circulation, energy conscious designs, maximum utilization of day lighting, employing plants as part of the integrated building design for natural air pollution filter.

THE ECUMENICAL CHAPEL shall have a ground area of 120sqm with an Architectural depiction that combines the mixture of contemporary and modern. The Chapel features should include among others the following, adequate spaces for storage for convergence and intercession. The Ecumenical Chapel floor layout shall consist of the following: Open area, Veranda spaces, and Entrance ways, prayer Room and Wudu/ablution area for spiritual cleansing.

The building shall be designed and constructed incorporating the sustainability principles of ecologically responsive building design and design considerations for environmental protection of the building and occupants from the elements of the

weather. Providing shade protection and open flow of natural air circulation are very important considerations in the design. The design parameters and performance standards are required to ensure that all aspects in the design and construction stages attain minimal impact to the environment while providing an ECUMENICAL CHAPEL that is resilient, of high standards and in harmony with its surroundings. a) Design Parameters: i. Site Analysis. A detailed site analysis shall be conducted for the purpose of analysis, recording and evaluating information on the site and its surroundings. The result of the analysis shall be used in the design process. The analysis shall include: Building Orientation; Wind Direction; Soil Type and Condition; Topography; Vegetation and Natural Features; Precipitation & Hydrology; Surrounding land uses & buildings; Prominent Vision lines / Visual linkages; and locally available resources ii. Site Planning this parameter shall be incorporated during the design of the building and shall include: Shape, size and orientation of the area where the building will be built; Levels and contours of the area and its surroundings; Height of existing buildings and its surroundings; Open spaces surrounding the property Natural or man-made structures. The design and construction of the building shall conform to the following standards: Energy Efficiency. Requires the adoption of efficient practices, designs, methods and technologies that reduce energy consumption resulting in cost savings. Water Efficiency. Requires the adoption of efficient practices, plan, design, materials, fixtures, equipment and methods that reduce water consumption resulting in cost savings. Material Sustainability. Material Sustainability governs all matters related to resource efficiency and material selection and use with the least impact on the environment. Solid Waste Management. Efficient waste management requires the adoption of efficient waste management practices and use of eco-friendly materials. Site Sustainability. Requires the adoption of planning, design, construction and operation practices that minimize the adverse impact of buildings on ecosystems and water resources. Indoor Environmental Quality. Requires the adoption of efficient design and operation practices that take into consideration the building environment to improve occupant health, productivity and safety.

II – PROJECT REQUIREMENTS

5. GENERAL

The following are the conditions/design criteria under which the proposed project shall be designed and constructed:

5.1 Project Objectives

5.1.1 Construction of quality **ECUMENICAL CHAPEL** building in such a way that it provides the best combination of “quality, functionality, comfort, appearance, environmental sustainability, safety, accessibility for occupants and equipment, weather protection of building and occupants, and the building technical infrastructure. On floors susceptible to wetting/flooding due to rain and drifts from strong wind shall be provided along the floor edges with gutter drains to serve as interceptor catchment to flooded floor and provided with properly laid discharge pipe outlets.

5.1.2 Construction of Landscape to depict a model projecting the harmony between nature and development emphasizing the prime concern for environmental preservation and balanced growth, landscape plantings will be used so as to dramatically improve the aesthetics of the building and improve the ambient air quality and reduce the heat island effect. As the available surrounding areas are limited, pocket gardens shall be considered in the overall landscaping design.

5.1.3 The **ECUMINECAL FACILITY** shall be planned and designed such that its characteristics and specifications keep up with the philosophy and goals of the DSWD FO-X by adopting the guidelines of internationally acceptable standards. The building shall be designed and constructed incorporating the sustainability principles of ecologically responsive building design and design considerations for environmental protection of the building and occupants from the elements of the weather. The design of the building shall be consistent with the master plan of the DSWD FO-X RRCY COMPLEX. The building aesthetics shall depict The **ECUMENICAL CHAPEL** architectural façade and elevation shall be such that the rustic and modern architecture merge and intersect. Preservation of existing site vegetation and other endangered plants and trees present at site shall be considered in the design of the site development plan. Where trees become an obstruction, efforts should be made to cause their relocation. If it is not practical a suitable replacement in the general landscaping plan should be provided to restore the balance of the removed trees oxygen generation abilities. Provision fire protection system must be included in the design of the building in accordance with the new Fire Code of the Philippines. Safety-conscious design and use of materials/finishes such as on fire resistivity, non-toxicity, dry type and non-slippery, slip and fall protection. Rain drift shall be prevented to drip inside the building door and window openings and fenestration. Window edges shall be kept watertight. Where fall hazard is imminent and obvious, provision for fall barriers and protection like providing grills shall be mandatory even if the approved plans and drawings did not indicate. General windows should allow natural ventilation to at least 100% of

identified areas for ventilation. Provision of ramps may be considered for compliance with BP 344. Energy efficient building envelope that allows for natural air circulation to flow into the building interiors. This is a mandatory requirement for the building sustainability features in the application of the green building design concepts. If the final building design and construction does not yield the required natural air circulation flow or the important sustainability features are lacking, the erected/installed building components in question shall be corrected and re-laid to meet the green building design features required at no extra cost to the Owner.

5.3 Space Requirements

Space requirements shall be referred from ECUMENICAL CHAPEL plan.

5.4 Project Process

To implement and complete the design development and construction of the proposed project at a **Guaranteed Maximum Price** as per scope of work described in **Section 4** herein, and as approved by **DSWD FO-X Technical Inspectors.**, the project **Owner** in conjunction with the direct End-Users.

The **Designer/Builder** shall provide for its account all materials, labor, equipment, tools, instruments and appliances needed or necessary to complete the “**Work**”. *Basic and fundamental requirements and/or components required in the TOR but not explicitly shown or whether inadvertently or intentionally missed out in the approved plans and drawings or details shall be provided/installed at no additional costs as if it were incorporated in the approved plans and drawings.*

5.4.1 Development of Theme Concept and Preliminary Scheme, Design of Site Development and its Aesthetic Features which will be finalized for approval together with the detailed Architectural and Engineering Design for review by Engr. Dept. and End-Users.

5.4.2 Detailed Architectural and Engineering Design of the approved Building Plan.

5.4.3 Construction of the proposed Site Development and Building Works and its required Infrastructures and Appurtenances as enumerated in Section 4 of this TOR.

5.4.4 The required design development and construction works shall be completed within a project timeframe of **ONE HUNDRED TWENTY (120)** calendar days for the scope of works enumerated in **Section 4** of this Performance Specifications and Parameters (TOR).

LOT 2: MAJOR REPAIR OF THE HOMELIFE BUILDING ROOF (DESIGN & BUILD)

II- GENERAL

1. INTRODUCTION

This project undertaking is aimed for the complete design and construction of the HOMELIFE BUILDING ROOF REPAIR at Regional Rehabilitation Center for Youth (RRCY), BRGY. KAHULOGAN, GINOGOOG CITY and its appurtenant structures at the DSWD FO-X COMPLEX, with the objective of producing a prime facility with the quality and character of environment appropriate to the aims of the DSWD FO-X.

2. OBJECTIVES

DSWD FO-X wishes to engage the services of a qualified Design/Build Firm to prepare the detailed architectural and engineering design plans as well as undertake the construction of the proposed **MAJOR REPAIR OF THE HOMELIFE BUILDING ROOF**. The objectives of this **PERFORMANCE SPECIFICATIONS AND PARAMETERS** herein referred to as **TOR** are as follows:

- 2.1 To provide the **Designer/Builder** with the background information regarding the preparation and submittal of the proposal;
- 2.2 To provide the **Designer/Builder** with the background information regarding the proposed project which should be handled in the shortest possible time, at the lowest possible cost and at an acceptable quality and performance;

3. ROLE OF THE DESIGNER/BUILDER

3.1 The **Designer/Builder**, for which this **PERFORMANCE SPECIFICATIONS AND PARAMETERS** applies, shall provide technical services in the preparation of the detailed Architectural and Engineering design for the proposed **MAJOR REPAIR OF THE HOMELIFE BUILDING ROOF** within the viable cost range and established design level. The design services shall be carried out in accordance with the **DSWD FO-X** and approved *Design Guidelines, Criteria and Facilities Standards*.

In this regard, the **Designer/Builder** or the key personnel to be assigned to the project must have adequate professional experience compatible with the undertaking.

- 3.2 The **Designer/Builder** shall also implement the construction activities to complete the project in accordance with the approved construction drawings and specifications and the scope of work as specified in the contract. **The Designer/Builder** shall carry out the construction activities under the supervision of the assigned **DSWD FO-X Technical Inspectors** qualified technical staff.
- 3.3 The **Designer/Builder** shall complete the services or “**Work**” within ONE HUNDRED TWENTY DAYS (120) calendar days scheduled as follows:

3.3.1 Detailed Design Phase including review by **DSWD FO-X Technical Inspectors** technical staff should be completed within ninety (15) calendar days.

3.3.2 Construction Phase should be completed within ONE HUNDRED TWENTY (120) calendar days.

4. EXTENT OF THE PROJECT

Scope of Work/Project Description

This project undertaking is aimed for the complete design and MAJOR REPAIR of the HOMELIFE BUILDING at RRCY COMPLEX with the objective of producing a prime facility with the quality and character of environment appropriate to the aims of the DSWD FO-X. Complete plans and shop drawings shall be submitted for the fabrication and erection of structural steel and steel TRUSSES based on DSWD structure design and concept drawings. Shop erection drawings shall be neat, adequately spaced, not crowded and as complete as necessary for the proper fabrication and erection of all parts and members of the steel structure, including the location, type/size of all bolts and welds. Enlarged sections and details shall be provided for all connections and whenever may be required. Structural steel members shall be marked prior to delivery to facilitate the erection of the members. Marking shall be listed and given descriptions. Complete material lists and bolt list shall be submitted to DSWD before any delivery is made. Approved by the DSWD - of shop and erection drawings submitted as "Approved for Construction" shall not in any way relieve the contractor of the correct dimensions of all sections used in the construction, quality of workmanship on the construction nor will such approval, relieve the contractor from responsibilities for errors of any sort of either by not following correctly the approved sections of structural members on his shop drawings or improper methods in the fabrications and section of the structure. The tender may be deemed to have been based on data, regarding physical condition at the sites. The contractor acknowledged and warrants that he has inspected and examined such site and their surroundings and has satisfied himself by submission of this tender as to form and nature of the sites, the quantities, and the nature of work and materials necessary for the completion of the works, and the means of access of the sites, the accommodation he may require and that he has obtained for himself, all other circumstances which may have influenced or affected his tender. No increase in cost or extension of time will be considered for failure to inspect and examine the site condition.

Complete construction of all tinsmith works including supply of all materials, labor, equipment and supervision necessary to properly conduct and produce the desired work product. Included herein are supply and installation of all roofing, ventilator sheets (if any), flashing, gutters, downspouts (up to catch basin and canal), sealant, fasteners, insect screens, and all temporary works and structures necessary for the efficient, smooth and up-to-date completion of the project.

Roofing shall be 0.400 mm thick (base metal) rib-type, pre-painted, long span galvanized iron (G.I.) sheet with a feed width of not more than 0.915m (3 feet). ii. Laying of roofing sheets should start from the end opposite the direction of the prevailing wind, overlap the next sheet to

the first sheet and fix according to fastening procedures. iii. Where roofing are to rest on steel purlins, use tekscrew at every ribs. In between washer and roof sheet, provide neoprene washer as water seal. iv. In addition, fasteners at the first corrugation of ever side lap shall be provided. All flashing and ridge rolls shall be min. 0.500 mm thick (base metal) plain, factory pre-painted and shape to dimensions indicated in the plans. ii. Fasten all flashing to the roofing sheets by means of rivets at every 0.30 m to 0.35 m on centers. Apply water-sealant on all rivets. Provide a minimum of 0.30 lapping for all flashing. Ceiling boards shall be 6.0 mm thick ordinary plywood with open joists securely nailed to the ceiling nailers with finishing nails spaced not more than 0.20 mm apart. Ceiling nailers shall be placed at 0.60 m.o.c. both ways unless otherwise known or detailed in the drawing. Metal Works - before any paint is applied, all surfaces shall be thoroughly clean, free from dirt, oil or grease, remove all scale, rust, and other foreign matter by de-rusting chemical, wire brushed, sand papered, and if so required, should be sandblasted, GI gutters down spouts and fascia shall receive a coat of red lead primer.

II – PROJECT REQUIREMENTS

5. GENERAL

The following are the conditions/design criteria under which the proposed project shall be designed and constructed:

5.1 Project Objectives

5.1.1 Construction of quality **MAJOR REPAIR OF THE HOMELIFE BUILDING ROOF** in such a way that it provides the best combination of “quality, functionality, comfort, appearance, environmental sustainability, safety, accessibility for occupants and equipment, weather protection of building and occupants, and the building technical infrastructure.

5.2 Project Process

To implement and complete the design development and construction of the proposed project at a **Guaranteed Maximum Price** as per scope of work described in **Section 4** herein, and as approved by **DSWD FO-X Technical Inspectors.**, the project **Owner** in conjunction with the direct End-Users.

The **Designer/Builder** shall provide for its account all materials, labor, equipment, tools, instruments and appliances needed or necessary to complete the “**Work**”. *Basic and fundamental requirements and/or components required in the TOR but not explicitly shown or whether inadvertently or intentionally missed out in the approved plans and drawings or details shall be provided/installed at no additional costs as if it were incorporated in the approved plans and drawings.*

5.2.1 Development of Theme Concept and Preliminary Scheme, Design of Site Development and its Aesthetic Features which will be finalized for approval together with the detailed Architectural and Engineering Design for review by Engr. Dept. and End-Users.

5.2.2 Detailed Architectural and Engineering Design of the approved Site Development Plan and Building Plan.

5.2.3 The required design development and construction works shall be completed within a project timeframe of **ONE HUNDRED TWENTY (120)** calendar days for the scope of works enumerated in **Section 4** of this Performance Specifications and Parameters (TOR).

DSWD-FOX

LOT 3: REHABILITATION OF BAHAY SILUNGAN BUILDING AND INSTALLATION OF FIRE ALARM AND DETECTION SYSTEM WITH SPRINKLERS (DESIGN & BUILD)

III- GENERAL

1. INTRODUCTION

This project undertaking is aimed for the complete design and construction of the REHABILITATION OF BAHAY SILUNGAN BUILDING AND INSTALLATION OF FIRE ALARM AND DETECTION SYSTEM WITH SPRINKLER at BAHAY SILUNGAN, DSWD ALAE COMPLEX, MANOLO FORTICH, BUKIDNON and its appurtenant structures at the DSWD FO-X COMPLEX, with the objective of producing a prime facility with the quality and character of environment appropriate to the aims of the DSWD FO-X. The resulting building should possess the quality and character needed to meet higher quality facilities with standards, and Fire Safety Standards of the Fire Code of the Philippines and at the same time meeting the requirements for safety.

2. OBJECTIVES

DSWD FO-X wishes to engage the services of a qualified Design/Build Firm to prepare the detailed architectural and engineering design plans as well as undertake the construction of the proposed **REHABILITATION OF BAHAY SILUNGAN BUILDING AND INSTALLATION OF FIRE ALARM AND DETECTION SYSTEM WITH SPRINKLERS**. The objectives of this **PERFORMANCE SPECIFICATIONS AND PARAMETERS** herein referred to as **TOR** are as follows:

2.1 To provide the **Designer/Builder** with the background information regarding the preparation and submittal of the proposal;

To provide the **Designer/Builder** with the background information regarding the proposed project which should be handled in the shortest possible time, at the lowest possible cost and at an acceptable quality and performance;

3. ROLE OF THE DESIGNER/BUILDER

3.1 The **Designer/Builder**, for which this **PERFORMANCE SPECIFICATIONS AND PARAMETERS** applies, shall provide technical services in the preparation of the detailed Architectural and Engineering design for the proposed **REHABILITATION OF BAHAY SILUNGAN AND INSTALLATION OF FIRE ALARM AND DETECTION SYSTEM WITH SPRINKLERS** within the viable cost range and established design level. The design services shall be carried out in accordance with the **DSWD FO-X** and approved *Design Guidelines, Criteria and Facilities Standards*.

In this regard, the **Designer/Builder** or the key personnel to be assigned to the project must have adequate professional experience compatible with the undertaking.

3.2 The **Designer/Builder** shall also implement the construction activities to complete the project in accordance with the approved construction drawings and specifications and the scope of work as specified in the contract. **The Designer/Builder** shall carry out the construction activities under the supervision of the assigned **DSWD FO-X Technical Inspectors** qualified technical staff.

3.3 The **Designer/Builder** shall complete the services or “**Work**” within ONE HUNDRED TWENTY DAYS (120) calendar days scheduled as follows:

3.3.1 Detailed Design Phase including review by **DSWD FO-X Technical Inspectors** technical staff should be completed within fifteen (15) calendar days.

3.3.2 Construction Phase should be completed within ONE HUNDRED TWENTY (120) calendar days.

4. EXTENT OF THE PROJECT

Scope of Work/Project Description

A fire protection, detection and alarm system are an important component of a building’s safety plan, regardless of whether it’s a commercial facility, hospital or educational facility. Without a fire protection system, the lives of those who are inside the building are placed at a high risk in the event of an emergency. A building’s fire protection, detection and alarm system play an important role in providing the building and its occupants with protection in the event of a fire. Each system approaches the threat differently, but is critical to the integrity of the building and the safety of those inside. However, in order for these systems to work properly they need to be maintained and kept up-to-date with the latest fire safety code. The works shall include but not limited to all materials, labor, tools, plant, equipment and other facilities including the management, coordination and supervision of these services, needed to complete and render good services for use of the Fire Protection System of the Building in accordance with the plans, specifications, codes, standards, pertinent governing rules and regulations and contract documents. Also, together with all temporary works, the securing of all necessary permits and approvals including application of notices, all liaison and coordination with the Statutory Authorities necessary to complete the Fire Protection Work package that satisfies the owner requirement and design intent.

The work covers the design and construction consisting of: (1) detailed Architecture and Engineering designs of, architectural, mechanical, electrical, pump specifications and provision for mechanical systems composed of jockey pumps and FDAS LAYOUT; (2) Detailed Estimates, Bill of Quantities, Scope of Works,

Technical Specifications, Proposed Design and Construction Schedule, Coverage of the rehabilitation works is approximately 1,376 square meter from ground to second floor. The fire alarm control panel (FACP) shall be the central processing unit of the system, receiving and analyzing signals from fire sensors, providing audible and visual information to the user, initiating automatic alarm response sequences and providing the means by which the user interacts with the system. The FACP shall be microprocessor based and operate under a multitasking software program. Operating programs and configuration data shall be contained in re-configurable non-volatile memory. Retention of the memory shall not rely on any form of battery or capacitor back-up device. The FACP shall incorporate separate processors for loop processing and central processing. Provision shall be made for each addressable loop to be subdivided into geographical zones. The section of wiring corresponding to each zone circuit shall be protected from faults in other sections by line isolator modules. In order to facilitate re-configuration and system extension, the allocation of addresses to devices shall be independent of their physical arrangement on the loops. Supply and installation of complete Automatic Fire Sprinkler System, Fire Extinguishing System in accordance of plan, specification, codes, standards, governing rules and regulations. These includes supply and installation of sprinkler heads, pipes and fittings, risers, feed main, cross main, branch line, droppings, all necessary valves and accessories, riser nipples, cross-tee, elbow, trims, hangers and supports, fire hose cabinets with complete accessories as per BFP standards, fire department connection, testing hose header, wall hydrants, roof manifolds, fire extinguishers, pipe sleeves including rebar and any stirrups as required by structural, block-out including rebar supports, fire stopping materials/fire sealant, sway brace, seismic bracing, painting, coupling, flow switch, floor control valves, sight glass, gauges, pumps and motors including controllers with ATS(Controllers is BAS - Building Automation System ready provided with dry contact), sensing line, tagging ITC, auxiliary drain, stub-out, flanges, mechanical grooved coupling (fix/rigid, flexible), remote annunciator panel, conduits (IMC, PVC, metal or liquid tight flexible conduit), wires/cables (Fire rated and non-fire rated) and all necessary equipment, pipes and fittings, materials, accessories, controllers, special fittings that make the system complete and operational that will satisfy the owner. This includes all necessary permits to be secured as required by the Local government or governing laws. Complete Fully Addressable Fire Detection and Alarm System (FDAS) including conduit extensions (flexible conduits from the embedded boxes and the like), fittings, boxes, supports, and accessories, wires and cables, terminal blocks, Fire Alarm Control Panel (FACP), Network Display Unit (NDU), Data Gathering Panel (DGP), Annunciator Panel, UPS, Amplifiers, smoke detectors with sounder base inside offices, smoke detectors at common area, life safety speakers, heat detectors, manual pull station, fire alarm speakers and strobe lights, relays, auxiliary contacts, individual relay module for supervisory switch and flow switch of fire protection system, addressable modules, monitoring and control interface modules and devices for local motor controllers, elevators, fire protection system, pressurization and ventilation, security and access control, parking system as detailed on the plans and specifications. DGP/Annunciators shall be connected and properly interface with the Network

Display Unit (NDU) and FACP. Wiring Class shall be Class A. FDAS shall be interface with Fire Protection System, Elevator Homing System, Elevator Pressurization Fan, Ventilation, Smoke Extraction and Pressurization System, Security and Access Control System and Parking System. FDAS workstation (one set per Tower) complete with printer, console table, furniture and chairs must be included.

All repair works are based on the actual site setting and can be referred on plans, cabinetry works, plumbing works, roofing repairs and roof extension with general roof accessories repair are also included.

II – PROJECT REQUIREMENTS

5. GENERAL

The following are the conditions/design criteria under which the proposed project shall be designed and constructed:

5.1 Project Objectives

5.1.1 Construction of quality **REHABILITATION OF BAHAY SILUNGAN BUILDING AND INSTALLATION OF FIRE ALARM AND DETECTION SYSTEM WITH SPRINKLER** in such a way that it provides the best combination of “quality, functionality, comfort, appearance, environmental sustainability, safety, accessibility for occupants and equipment

5.2 Space Requirements

Space requirements shall be referred from the rehabilitation plan.

5.3 Project Process

To implement and complete the design development and construction of the proposed project at a **Guaranteed Maximum Price** as per scope of work described in **Section 4** herein, and as approved by **DSWD FO-X Technical Inspectors.**, the project **Owner** in conjunction with the direct End-Users.

The **Designer/Builder** shall provide for its account all materials, labor, equipment, tools, instruments and appliances needed or necessary to complete the “**Work**”. *Basic and fundamental requirements and/or components required in the TOR but not explicitly shown or whether inadvertently or intentionally missed out in the approved plans and drawings or details shall be provided/installed at no additional costs as if it were incorporated in the approved plans and drawings.*

- 5.3.1 Development of Theme Concept and Preliminary Scheme, Design of Site Development and its Aesthetic Features which will be finalized for approval together with the detailed Architectural and Engineering Design for review by Engr. Dept. and End-Users.

- 5.3.2 Detailed Architectural and Engineering Design of the approved Building Plan.
- 5.3.3 Construction of the proposed Site Development and Building Works and its required Infrastructures and Appurtenances as enumerated in Section 4 of this TOR.
- 5.3.4 The required design development and construction works shall be completed within a project timeframe of **ONE HUNDRED TWENTY (120)** calendar days for the scope of works enumerated in **Section 4** of this Performance Specifications and Parameters (TOR).

DSWD-FOX

**LOT 4: CONSTRUCTION OF STORAGE WAREHOUSE FOR BAHAY SILUNGAN
(DESIGN & BUILD)**

IV. GENERAL

1. INTRODUCTION

This project undertaking is aimed for the complete design and construction of the STORAGE WAREHOUSE at Bahay Silungan and its appurtenant structures at the DSWD FO-X COMPLEX, with the objective of producing a prime facility with the quality and character of environment appropriate to the aims of the DSWD FO-X. The resulting building should possess the quality and character needed to meet higher quality facilities with standards, complying the National Building Code regulations and Fire Safety Standards of the Fire Code of the Philippines and at the same time meeting the requirements for sustainable design providing green features of design like allowing natural air circulation, energy conscious designs, maximum utilization of day lighting, employing plants as part of the integrated building design for natural air pollution filter and carbon removal and improving the indoor and outdoor air quality of the building and conservation of water use through rain collection and utilization.

2. OBJECTIVES

DSWD FO-X wishes to engage the services of a qualified Design/Build Firm to prepare the detailed architectural and engineering design plans as well as undertake the construction of the proposed **STORAGE WAREHOUSE**. The objectives of this **PERFORMANCE SPECIFICATIONS AND PARAMETERS** herein referred to as **TOR** are as follows:

- 2.1 To provide the **Designer/Builder** with the background information regarding the preparation and submittal of the proposal;
- 2.2 To provide the **Designer/Builder** with the background information regarding the proposed project which should be handled in the shortest possible time, at the lowest possible cost and at an acceptable quality and performance;

3. ROLE OF THE DESIGNER/BUILDER

- 3.1 The **Designer/Builder**, for which this **PERFORMANCE SPECIFICATIONS AND PARAMETERS** applies, shall provide technical services in the preparation of the detailed Architectural and Engineering design for the proposed **STORAGE WAREHOUSE** within the viable cost range and established design level. The design services shall be carried out in accordance with the **DSWD FO-X** and approved *Design Guidelines, Criteria and Facilities Standards*.

In this regard, the **Designer/Builder** or the key personnel to be assigned to the project must have adequate professional experience compatible with the undertaking.

- 3.2 The **Designer/Builder** shall also implement the construction activities to complete the project in accordance with the approved construction drawings and specifications and the scope of work as specified in the contract. **The Designer/Builder** shall carry

out the construction activities under the supervision of the assigned **DSWD FO-X Technical Inspectors** qualified technical staff.

3.3 The **Designer/Builder** shall complete the services or “**Work**” within ONE HUNDRED TWENTY DAYS (120) calendar days scheduled as follows:

3.3.1 Detailed Design Phase including review by **DSWD FO-X Technical Inspectors** technical staff should be completed within fifteen (15) calendar days.

3.3.2 Construction Phase should be completed within ONE HUNDRED TWENTY (120) calendar days.

4. EXTENT OF THE PROJECT

Scope of Work/Project Description

Design and Build of the STORAGE FACILITY design concepts are as indicated in the conceptual plans. The works consist of the following:

Complete design of the **STORAGE WAREHOUSE** by providing DSWD FO-X with a detailed plans and working drawings, specifications and detailed cost estimates and derivations of unit cost comprising of the Architectural, Structural, , Electrical, Sanitary & Plumbing, , Ground Development & Drainage Plans, and other relevant plans and details necessary for the construction of the **STORAGE WAREHOUSE**. The required detailed plans shall include the structural design, analyses and calculations, electrical and other pertinent design calculations carried out and included normally in the complete design of the building. The plan submittals shall also include a comprehensive construction specifications describing in details the quality of materials to be used, the quality of workmanship to be expected, the tests to be carried out, measurement of payment, and other relevant information necessary for the complete construction of the project. The detailed plans and detailed cost estimates shall be broken down into component items as follows:

STORAGE WAREHOUSE

The project consists of providing Design/Build services for the design and construction of the proposed **STORAGE WAREHOUSE** which consists of the following project component:

- a) **STORAGE WAREHOUSE** shall have a ground area of 150sqm with an Architectural depiction that combines the mixture of rustic and modern architectural mix and should include among others the following feature:
 - a. Adequate spaces for storage for food and non-food items.
 - b. All areas must be in a temperature control state.
 - c. All areas must be properly treated to block the penetration of unwanted insects and termites.
 - d. Entire **STORAGE WAREHOUSE** shall be equipped with an exhaust and proper ventilation.

- e. All exterior glass shall be reflective glass at least 6mm thick on 3mm thick aluminum frame and all exterior windows shall be reflective sliding glass on 3mm thick aluminum frame and provided with 90deg. Awning type transom. Safety metal grills shall be provided at the inner side of all the glass window easily reached or accessible to burglars and thieves. For every room where windows are grilled, one metal grill panel should be easily opened in case of emergencies and fire.
 - f. All flooring finishes for corridors and hallways shall be made of good quality ceramic non-skid tiles, 24"x24" preferred tile size. Use good quality ceramic tiles 24"x24" for other rooms. Tile adhesive to be used shall be heavy duty type, compatible and appropriate to granite/ceramic tiles which requires high adhesion properties to smooth and impermeable surfaces. Samples for tiles and corresponding adhesives shall be submitted for approval before any tiling work begins.
- b) The **STORAGE WAREHOUSE** floor layout shall consist of the following:
- a. Nonfood storage
 - b. Food storage area
 - c. Receiving area
 - d. Sorting area
 - e. Proper racking and cabinetry storage

II – PROJECT REQUIREMENTS

5. GENERAL

The following are the conditions/design criteria under which the proposed project shall be designed and constructed:

5.1 Project Objectives

5.1.1 Construction of quality **STORAGE WAREHOUSE** building in such a way that it provides the best combination of “quality, functionality, comfort, appearance, environmental sustainability, safety, accessibility for occupants and Equipment, weather protection of building and occupants, and the building, Technical infrastructure. On floors susceptible to wetting/flooding due to rain and drifts from strong wind shall be provided along the floor edges with gutter drains to serve as interceptor catchment to flooded floor and provided with properly laid discharge pipe outlets.

5.1.2 Depict a model projecting the harmony between nature and development emphasizing the prime concern for, Environmental preservation and balanced growth, landscape plantings will be used so as to dramatically improve the aesthetics of the building and Improve the ambient air quality and reduce the heat island effect. As the available surrounding areas are limited, pocket gardens shall be considered in the overall landscaping design.

5.1.3 The **STORAGE WAREHOUSE** shall be planned and designed such that its characteristics and specifications keep up with the philosophy and goals of The DSWD FO-X by adopting the guidelines of internationally acceptable standards.

5.2 Space Requirements

Space requirements shall be referred from storage plan and design.

5.3 Project Process

To implement and complete the design development and construction of the proposed project at a **Guaranteed Maximum Price** as per scope of work described in **Section 4** herein, and as approved by **DSWD FO-X Technical Inspectors.**, the project **Owner** in conjunction with the direct End-Users.

The **Designer/Builder** shall provide for its account all materials, labor, equipment, tools, instruments and appliances needed or necessary to complete the “**Work**”. *Basic and fundamental requirements and/or components required in the TOR but not explicitly shown or whether inadvertently or intentionally missed out in the approved plans and drawings or details shall be provided/installed at no additional costs as if it were incorporated in the approved plans and drawings.*

5.3.1 Development of Theme Concept and Preliminary Scheme, Design of Site Development and its Aesthetic Features which will be finalized for approval together with the detailed Architectural and Engineering Design for review by Engr. Dept. and End-Users.

5.3.2 Detailed Architectural and Engineering Design of the approved Site Development Plan and Building Plan.

5.3.3 Construction of the proposed Site Development and Building Works and its required Infrastructures and Appurtenances as enumerated in Section 4 of this TOR.

5.3.4 The required design development and construction works shall be completed within a project timeframe of **ONE HUNDRED TWENTY (120)** calendar days for the scope of works enumerated in **Section 4** of this Performance Specifications and Parameters (TOR).

LOT 5: CONSTRUCTION OF PUMPHOUSE WITH EQUIPMENT (DESIGN AND BUILD)

V. GENERAL

INTRODUCTION

This project undertaking is aimed for the complete design and construction of the PUMPHOUSE FACILITY W/ EQUIPMENT for Bahay Silungan and RHFWD, DSWD COMPOUND, ALAE, MANOLO FORTICH and its appurtenant structures at the DSWD FO-X COMPLEX, with the objective of producing a prime facility with the quality and character of environment appropriate to the aims of the DSWD FO-X.

1. OBJECTIVES

DSWD FO-X wishes to engage the services of a qualified Design/Build Firm to prepare the detailed architectural and engineering design plans as well as undertake the construction of the proposed **CONSTRUCTION OF PUMPHOUSE WITH EQUIPMENT**. The objectives of this **PERFORMANCE SPECIFICATIONS AND PARAMETERS** herein referred to as **TOR** are as follows:

2.1 To provide the **Designer/Builder** with the background information regarding the preparation and submittal of the proposal;

To provide the **Designer/Builder** with the background information regarding the proposed project which should be handled in the shortest possible time, at the lowest possible cost and at an acceptable quality and performance;

2. ROLE OF THE DESIGNER/BUILDER

3.1 The **Designer/Builder**, for which this **PERFORMANCE SPECIFICATIONS AND PARAMETERS** applies, shall provide technical services in the preparation of the detailed Architectural and Engineering design for the proposed **CONSTRUCTION OF PUMPHOUSE WITH EQUIPMENT** within the viable cost range and established design level. The design services shall be carried out in accordance with the **DSWD FO-X** and approved *Design Guidelines, Criteria and Facilities Standards*.

In this regard, the **Designer/Builder** or the key personnel to be assigned to the project must have adequate professional experience compatible with the undertaking.

3.2 The **Designer/Builder** shall also implement the construction activities to complete the project in accordance with the approved construction drawings and specifications and the scope of work as specified in the contract. **The Designer/Builder** shall carry out the construction activities under the supervision of the assigned **DSWD FO-X Technical Inspectors** qualified technical staff.

3.3 The **Designer/Builder** shall complete the services or “**Work**” within ONE HUNDRED TWENTY DAYS (120) calendar days scheduled as follows:

3.3.1 Detailed Design Phase including review by **DSWD FO-X Technical Inspectors** technical staff should be completed within fifteen (15) calendar days.

3.3.2 Construction Phase should be completed within ONE HUNDRED TWENTY (120) calendar days.

3. EXTENT OF THE PROJECT

The work covers the design and construction consisting of:

(1) Detailed Architecture and Engineering designs of Pump House Plans, Elevations and Sections in Structural/Civil, Architectural, Mechanical, Electrical, Pump Specifications and Provision for Mechanical Systems Composed of Exhaust Fans System, and Ventilation.

Pump room is enclosed in concrete and fully furnished with gloss paint inside and outside. Aluminum louver windows shall be installed for ventilation purposes. For the access of authorized personnel, a steel panel door shall be installed, and a roll-up door will be used for access of equipment. Safety signage shall be installed in proper places.

The Main pumphouse will serve as the main Water Control Facility for all the buildings at DSWD. See the following for the scope of works for the main pumphouse.

- i. Electrical Works – Pump house should be well illuminated and the design of the installation of the electrical panel board, pipes, fittings, boxes, wires, outlet, and fixtures should be based on the Philippine Electrical Code.
- ii. Architectural Works– The flooring of the pumphouse should be painted with the approved color of industrial epoxy paint.
- iii. Ceiling Works – The ceiling of the pumphouse should be metal furring framing with hanger accessories and 12mm gypsum moisture resistant or fire-retardant board. Provide also a Fire Rated Doors for the Main Door which will be a Double Door.
- iv. Mechanical Works – The contractor shall provide a Fire Protection system and a drainage system for the safety of these facilities.
- v. Structural Works– The design shall be in accordance with all the applicable laws and regulations of the Government of the Philippines and with the applicable local codes and ordinances. Due to the slope of the existing earth surface from the perimeter fence to the location of the concrete pedestal and the main powerhouse, the Main Powerhouse and concrete pedestal shall be elevated and the perimeter of the location shall have a Slope protection. Perimeter walls shall be constructed around the perimeter of the location of the main pumphouse and the concrete pedestal (See the design concept for the location of the main powerhouse and concrete pedestal).

II – PROJECT REQUIREMENTS

5. GENERAL

The following are the conditions/design criteria under which the proposed project shall be designed and constructed:

5.1 Project Objectives

5.1.1 Construction of quality **CONSTRUCTION OF PUMPHOUSE WITH EQUIPMENT** in such a way that it provides the best combination of “quality, functionality, comfort, appearance, environmental sustainability, safety, accessibility for occupants and equipment

5.2 Space Requirements

Space requirements shall be referred from rehabilitation plan.

5.3 Project Process

To implement and complete the design development and construction of the proposed project at a **Guaranteed Maximum Price** as per scope of work described in **Section 4** herein, and as approved by **DSWD FO-X Technical Inspectors.**, the project **Owner** in conjunction with the direct End-Users.

The **Designer/Builder** shall provide for its account all materials, labor, equipment, tools, instruments and appliances needed or necessary to complete the “**Work**”. *Basic and fundamental requirements and/or components required in the TOR but not explicitly shown or whether inadvertently or intentionally missed out in the approved plans and drawings or details shall be provided/installed at no additional costs as if it were incorporated in the approved plans and drawings.*

5.4.1 Development of Theme Concept and Preliminary Scheme, Design of Site Development and its Aesthetic Features which will be finalized for approval together with the detailed Architectural and Engineering Design for review by Engr. Dept. and End-Users.

5.4.2 Detailed Architectural and Engineering Design of the approved Building Plan.

5.4.3 Construction of the proposed Site Development and Building Works and its required Infrastructures and Appurtenances as enumerated in Section 4 of this TOR.

5.4.3 The required design development and construction works shall be completed within a project timeframe of **ONE HUNDRED TWENTY (120)** calendar days for the scope of works enumerated in **Section 4** of this Performance Specifications and Parameters (TOR).

LOT 6: CONSTRUCTION OF POWERHOUSE WITH EQUIPMENT (DESIGN AND BUILD)

VI. GENERAL

1. INTRODUCTION

This project undertaking is aimed for the complete design and construction of the POWERHOUSE FACILITY W/ EQUIPMENT for Bahay Silungan and RHFV, DSWD COMPOUND, ALAE, MANOLO FORTICH and its appurtenant structures at the DSWD FO-X COMPLEX, with the objective of producing a prime facility with the quality and character of environment appropriate to the aims of the DSWD FO-X.

2. OBJECTIVES

DSWD FO-X wishes to engage the services of a qualified Design/Build Firm to prepare the detailed architectural and engineering design plans as well as undertake the construction of the proposed **CONSTRUCTION OF POWERHOUSE WITH EQUIPMENT**. The objectives of this **PERFORMANCE SPECIFICATIONS AND PARAMETERS** herein referred to as **TOR** are as follows:

2.1 To provide the **Designer/Builder** with the background information regarding the preparation and submittal of the proposal;

To provide the **Designer/Builder** with the background information regarding the proposed project which should be handled in the shortest possible time, at the lowest possible cost and at an acceptable quality and performance;

3. ROLE OF THE DESIGNER/BUILDER

3.1 The **Designer/Builder**, for which this **PERFORMANCE SPECIFICATIONS AND PARAMETERS** applies, shall provide technical services in the preparation of the detailed Architectural and Engineering design for the proposed **CONSTRUCTION OF POWERHOUSE WITH EQUIPMENT** within the viable cost range and established design level. The design services shall be carried out in accordance with the **DSWD FO-X** and approved *Design Guidelines, Criteria and Facilities Standards*.

In this regard, the **Designer/Builder** or the key personnel to be assigned to the project must have adequate professional experience compatible with the undertaking.

3.2 The **Designer/Builder** shall also implement the construction activities to complete the project in accordance with the approved construction drawings and specifications and the scope of work as specified in the contract. **The Designer/Builder** shall carry out the construction activities under the supervision of the assigned **DSWD FO-X Technical Inspectors** qualified technical staff.

3.3 The **Designer/Builder** shall complete the services or “**Work**” within ONE HUNDRED TWENTY DAYS (120) calendar days scheduled as follows:

3.3.1 Detailed Design Phase including review **by DSWD FO-X Technical Inspectors** technical staff should be completed within fifteen (15) calendar days.

3.3.2 Construction Phase should be completed within ONE HUNDRED TWENTY (120) calendar days.

4. EXTENT OF THE PROJECT

The work covers the design and construction consisting of: (1) detailed Architecture and Engineering designs of Powerhouse Facility plans, elevations and sections in structural/civil, architectural, mechanical, electrical, generator specifications and provision for mechanical systems composed of exhaust fans system, and ventilation; (2) Detailed Estimates, Bill of Quantities, Scope of Works, Technical Specifications, Proposed Design and Construction Schedule, Health and Safety Program for the construction phase; (3) permit processing and acquisition at concerned agencies (i.e. Building Permit, Electrical Permit, Sanitary Permit, Mechanical Permit, Zoning Certificate, Fire Safety Certificate, Occupancy Permit, etc); (4) project billboard and temporary facilities for the engineer; (5) supply and furnishing of all labor, materials, and equipment necessary for the operation, commissioning and occupancy of the building.

The project shall be Design and Build under R.A 7920 Electrical Engineer Law, Philippine Electrical Code (PEC), National Electrical code and the New Fire code of the Philippines which shall be designed and approved by a Professional Electrical Engineer. The reason of having Underground Electrical service for this campus compared to overhead cables, underground electrical service is safely because underground electrical cables are not exposed to many dangers and obstruction than overhead power cables. In addition, Underground transmission of Electricity increases reliability because instances of constant disruption in the supply of power as a result of storms or faults that are associated with overhead transmission lines are not common when power transmission lines are laid underground. This underground distribution design shall compose all details about the electrical, mechanical, plumbing, structural, and architectural designs for this underground distribution, from the main feeder line to the main stub – outs per buildings including the underground auxiliary details for the CATV, WAN/LAN, and INTERCOM provision.

The Main Distribution panel also known as panel board, breaker panel, or electric panel is a component of an electricity supply system that divides an electrical power feed into subsidiary circuits, while providing a protective fuse or circuit breaker for each circuit in a common enclosure. The Main distribution panel will serve as the main electrical panel for the DSWD buildings and facilities. This will be placed in the designated Electrical room inside the Main powerhouse. The contractor shall provide the exact design for this electrical panel based on the total load Capacity of the DSWD ALAE COMPLEX.

Main Powerhouse & Concrete Pedestal

The Main powerhouse will serve as the main Electrical Control Facility for all the buildings at DSWD. All the Electrical Circuit Breakers per building, automatic transfer

switch, and Main Distribution Panel from the main supply will be placed in the designated EE room inside the powerhouse. See the following for the scope of works for the main powerhouse.

- i. **Electrical Works** – Power house should be well illuminated and the design of the installation of the electrical panel board, pipes, fittings, boxes, wires, outlet, and fixtures should be based on the Philippine Electrical Code.
- ii. **Architectural Works**– The flooring of the power house should be painted with the approved color of industrial epoxy paint.
- iii. **Ceiling Works** – The ceiling of the power house should be metal furring framing with hanger accessories and 12mm gypsum moisture resistant or fire-retardant board. Provide also a Fire Rated Doors for the Main Door which will be a Double Door and for the EE room with a single door.
- iv. **Mechanical Works** – The contractor shall provide a Fire Protection system and a drainage system for the safety of these facilities.
- v. **Structural Works**– Due to slope of the existing earth surface from the perimeter fence to the location of the concrete pedestal and the main powerhouse, the Main Powerhouse and concrete pedestal shall be elevated and the perimeter of the location shall have a Slope protection. Perimeter wall shall be constructed around the perimeter of the location of the main powerhouse and the concrete pedestal (See the design concept for the location of the main powerhouse and concrete pedestal).
- vi. **Electrical Room**– Shall be enclosed by a concrete wall with proper ventilation; approximately the dimension of this EE room would be 3m in length, 3m in width and 3m in height.

II – PROJECT REQUIREMENTS

5. GENERAL

The following are the conditions/design criteria under which the proposed project shall be designed and constructed:

5.1 Project Objectives

5.1.1 Construction of quality **CONSTRUCTION OF POWERHOUSE WITH EQUIPMENT** in such a way that it provides the best combination of “quality, functionality, comfort, appearance, environmental sustainability, safety, accessibility for occupants and equipment

5.2 Space Requirements

Space requirements shall be referred from rehabilitation plan.

5.3 Project Process

To implement and complete the design development and construction of the proposed project at a **Guaranteed Maximum Price** as per scope of work described in **Section 4** herein, and as approved by **DSWD FO-X Technical Inspectors.**, the project **Owner** in conjunction with the direct End-Users.

The **Designer/Builder** shall provide for its account all materials, labor, equipment, tools, instruments and appliances needed or necessary to complete the “**Work**”. *Basic and fundamental requirements and/or components required in the TOR but not explicitly shown or whether inadvertently or intentionally missed out in the approved plans and drawings or details shall be provided/installed at no additional costs as if it were incorporated in the approved plans and drawings.*

5.3.1 Development of Theme Concept and Preliminary Scheme, Design of Site Development and its Aesthetic Features which will be finalized for approval together with the detailed Architectural and Engineering Design for review by Engr. Dept. and End-Users.

5.3.2 Detailed Architectural and Engineering Design of the approved Building Plan.

5.4.3 Construction of the proposed Site Development and Building Works and its required Infrastructures and Appurtenances as enumerated in Section 4 of this TOR.

5.4.4 The required design development and construction works shall be completed within a project timeframe of **ONE HUNDRED TWENTY (120)** calendar days for the scope of works enumerated in **Section 4** of this Performance Specifications and Parameters (TOR).

**LOT 7: CONSTRUCTION OF STORAGE WAREHOUSE FOR REGIONAL HAVEN FOR
WOMEN (DESIGN & BUILD)**

VII. GENERAL

1. INTRODUCTION

This project undertaking is aimed for the complete design and construction of the STORAGE WAREHOUSE at REGIONAL HAVEN FOR WOMEN, DSWD COMPOUND, ALAE, MANOLO FORTICH and its appurtenant structures at the DSWD FO-X COMPLEX, with the objective of producing a prime facility with the quality and character of environment appropriate to the aims of the DSWD FO-X. The resulting building should possess the quality and character needed to meet higher quality facilities with standards, complying the National Building Code regulations and Fire Safety Standards of the Fire Code of the Philippines and at the same time meeting the requirements for sustainable design providing green features of design like allowing natural air circulation, energy conscious designs, maximum utilization of day lighting, employing plants as part of the integrated building design for natural air pollution filter and carbon removal and improving the indoor and outdoor air quality of the building and conservation of water use through rain collection and utilization.

2. OBJECTIVES

DSWD FO-X wishes to engage the services of a qualified Design/Build Firm to prepare the detailed architectural and engineering design plans as well as undertake the construction of the proposed **STORAGE WAREHOUSE**. The objectives of this **PERFORMANCE SPECIFICATIONS AND PARAMETERS** herein referred to as **TOR** are as follows:

- 2.1 To provide the **Designer/Builder** with the background information regarding the preparation and submittal of the proposal;
- 2.2 To provide the **Designer/Builder** with the background information regarding the proposed project which should be handled in the shortest possible time, at the lowest possible cost and at an acceptable quality and performance;

3. ROLE OF THE DESIGNER/BUILDER

- 3.1 The **Designer/Builder**, for which this **PERFORMANCE SPECIFICATIONS AND PARAMETERS** applies, shall provide technical services in the preparation of the detailed Architectural and Engineering design for the proposed **STORAGE WAREHOUSE** within the viable cost range and established design level. The design services shall be carried out in accordance with the **DSWD FO-X** and approved *Design Guidelines, Criteria and Facilities Standards*.

In this regard, the **Designer/Builder** or the key personnel to be assigned to the project must have adequate professional experience compatible with the undertaking.

- 3.2 The **Designer/Builder** shall also implement the construction activities to complete the project in accordance with the approved construction drawings and specifications

and the scope of work as specified in the contract. **The Designer/Builder** shall carry out the construction activities under the supervision of the assigned **DSWD FO-X Technical Inspectors** qualified technical staff.

3.3 The **Designer/Builder** shall complete the services or “**Work**” within ONE HUNDRED TWENTY DAYS (120) calendar days scheduled as follows:

3.3.1 Detailed Design Phase including review by **DSWD FO-X Technical Inspectors** technical staff should be completed within fifteen (15) calendar days.

3.3.2 Construction Phase should be completed within ONE HUNDRED TWENTY (120) calendar days.

4. EXTENT OF THE PROJECT

4.1 Scope of Work/Project Description

Design and Build of the STORAGE WAREHOUSE design concepts are as indicated in the conceptual plans. The works consist of the following:

Complete design of the **STORAGE WAREHOUSE** by providing DSWD FO-X with a detailed plans and working drawings, specifications and detailed cost estimates and derivations of unit cost comprising of the Architectural, Structural, , Electrical, Sanitary & Plumbing, , Ground Development & Drainage Plans, and other relevant plans and details necessary for the construction of the **STORAGE FACILITY**. The required detailed plans shall include the structural design, analyses and calculations, electrical and other pertinent design calculations carried out and included normally in the complete design of the building. The plan submittals shall also include a comprehensive construction specifications describing in details the quality of materials to be used, the quality of workmanship to be expected, the tests to be carried out, measurement of payment, and other relevant information necessary for the complete construction of the project. The detailed plans and detailed cost estimates shall be broken down into component items as follows:

STORAGE WAREHOUSE

The project consists of providing Design/Build services for the design and construction of the proposed **STORAGE WAREHOUSE** which consists of the following project component:

- a) **STORAGE WAREHOUSE** shall have ground area of 100sqm with an Architectural depiction that combines the mixture of rustic and modern architectural mix and should include among others the following feature:
 - a. Adequate spaces for storage for food and non-food items.
 - b. All areas must be in a temperature control state.
 - c. All areas must be properly treated to block the penetration of unwanted insects and termites.
 - d. Entire **STORAGE WAREHOUSE** shall be equipped with an exhaust and proper ventilation.
 - e. All exterior glass shall be reflective glass at least 6mm thick on 3mm thick aluminum frame and all exterior windows shall be reflective sliding glass on 3mm thick aluminum frame and provided with 90deg. Awning type transom. Safety metal grills shall be provided at the inner side of all the glass window easily reached or accessible to

burglars and thieves. For every room where windows are grilled, one metal grill panel should be easily opened in case of emergencies and fire.

- f. All flooring finishes for corridors and hallways shall be made of good quality ceramic non-skid tiles, 24"x24" preferred tile size. Use good quality ceramic tiles 24"x24" for other rooms. Tile adhesive to be used shall be heavy duty type, compatible and appropriate to granite/ceramic tiles which requires high adhesion properties to smooth and impermeable surfaces. Samples for tiles and corresponding adhesives shall be submitted for approval before any tiling work begin.

b) The **STORAGE WAREHOUSE** floor layout shall consist of the following:

- a. Nonfood storage
- b. Food storage area
- c. Receiving area
- d. Sorting area
- e. Proper racking and cabinetry storage

II – PROJECT REQUIREMENTS

5. GENERAL

The following are the conditions/design criteria under which the proposed project shall be designed and constructed:

5.1 Project Objectives

5.1.1 Construction of quality **STORAGE WAREHOUSE** building in such a way that it provides The best combination of “quality, functionality, comfort, appearance, environmental sustainability, safety, accessibility for occupants and Equipment, weather protection of building and occupants, and the building, Technical infrastructure. On floors susceptible to wetting/flooding due to rain and drifts from strong wind shall be provided along the floor edges with gutter drains to serve as interceptor catchment to flooded floor and provided with properly laid discharge pipe outlets.

5.1.2 Depict a model projecting the harmony between nature and development emphasizing the prime concern for, Environmental preservation and balanced growth, landscape plantings will be used so as to dramatically improve the aesthetics of the building and Improve the ambient air quality and reduce the heat island effect. As the available surrounding areas are limited, pocket gardens shall be considered in the overall landscaping design.

5.1.3 The **STORAGE WAREHOUSE** shall be planned and designed such that its characteristics and specifications keep up with the philosophy and goals of The DSWD FO-X by adopting the guidelines of internationally acceptable standards.

5.2 Space Requirements

Space requirements shall be referred from storage plan and design.

5.3 Project Process

To implement and complete the design development and construction of the proposed project at a **Guaranteed Maximum Price** as per scope of work described in **Section 4** herein, and as approved by **DSWD FO-X Technical Inspectors.**, the project **Owner** in conjunction with the direct End-Users.

The **Designer/Builder** shall provide for its account all materials, labor, equipment, tools, instruments and appliances needed or necessary to complete the “**Work**”. *Basic and fundamental requirements and/or components required in the TOR but not explicitly shown or whether inadvertently or intentionally missed out in the approved plans and drawings or details shall be provided/installed at no additional costs as if it were incorporated in the approved plans and drawings.*

- 5.3.1 Development of Theme Concept and Preliminary Scheme, Design of Site Development and its Aesthetic Features which will be finalized for approval together with the detailed Architectural and Engineering Design for review by Engr. Dept. and End-Users.
- 5.3.2 Detailed Architectural and Engineering Design of the approved Site Development Plan and Building Plan.
- 5.3.3 Construction of the proposed Site Development and Building Works and its required Infrastructures and Appurtenances as enumerated in Section 4 of this TOR.
- 5.3.4 The required design development and construction works shall be completed within a project timeframe of **ONE HUNDRED TWENTY (120)** calendar days for the scope of works enumerated in **Section 4** of this Performance Specifications and Parameters (TOR).

LOT 8: CONSTRUCTION OF ROADWAY AND PARKING AREA (DESIGN & BUILD)

VIII. GENERAL

1. INTRODUCTION

This project undertaking is aimed for the complete design and construction of the ROADWAY AND PARKING AREA at Bahay Silungan and RHFw, DSWD COMPOUND, ALAE, MANOLO FORTICH and its appurtenant structures at the DSWD FO-X COMPLEX, with the objective of producing a prime facility with the quality and character of environment appropriate to the aims of the DSWD FO-X.

2. OBJECTIVES

DSWD FO-X wishes to engage the services of a qualified Design/Build Firm to prepare the detailed architectural and engineering design plans as well as undertake the construction of the proposed **CONSTRUCTION OF ROADWAY AND PARKING AREA**. The objectives of this **PERFORMANCE SPECIFICATIONS AND PARAMETERS** herein referred to as **TOR** are as follows:

- 2.1 To provide the **Designer/Builder** with the background information regarding the preparation and submittal of the proposal;
- 2.2 To provide the **Designer/Builder** with the background information regarding the proposed project which should be handled in the shortest possible time, at the lowest possible cost and at an acceptable quality and performance;

3. ROLE OF THE DESIGNER/BUILDER

3.1 The **Designer/Builder**, for which this **PERFORMANCE SPECIFICATIONS AND PARAMETERS** applies, shall provide technical services in the preparation of the detailed Architectural and Engineering design for the proposed **CONSTRUCTION OF ROADWAY AND PARKING AREA** building within the viable cost range and established design level. The design services shall be carried out in accordance with the **DSWD FO-X** and approved *Design Guidelines, Criteria and Facilities Standards*.

In this regard, the **Designer/Builder** or the key personnel to be assigned to the project must have adequate professional experience compatible with the undertaking.

- 3.2 The **Designer/Builder** shall also implement the construction activities to complete the project in accordance with the approved construction drawings and specifications and the scope of work as specified in the contract. **The Designer/Builder** shall carry out the construction activities under the supervision of the assigned **DSWD FO-X Technical Inspectors** qualified technical staff.
- 3.3 The **Designer/Builder** shall complete the services or “**Work**” within ONE HUNDRED TWENTY DAYS (120) calendar days scheduled as follows:

3.3.1 Detailed Design Phase including review by **DSWD FO-X Technical Inspectors** technical staff should be completed within fifteen (15) calendar days.

3.3.2 Construction Phase should be completed within ONE HUNDRED TWENTY (120) calendar days.

4. EXTENT OF THE PROJECT

The work covers the design and construction consisting of: (1) detailed Architecture and Engineering designs of roadway and parking plans, and sections in structural/civil, The Department of Social Welfare and Development ALAE COMPLEX the entrance to the complex is through a main gate from the access road. This service road is expected to cater to the needs of the DSWD clients since it is envisioned to provide easy access of motor vehicles for deliveries as well as an alternate but quick emergency service route for emergency vehicles. The proposed Construction of Roadway and Parking Area is composed of the following work items; Site evaluation and surveying activities for the proposed roadway; Conduct of a slope stability analysis to identify critical areas along the proposed roadway; Construction of a pavement capable of sustaining vehicular traffic and to serve as the service roadway; This project shall be designed on the basis of safety, functionality, feasibility and aesthetics.

The proposed project shall have two main phases: the design phase and the construction phase, and shall put emphasis on the most feasible and functional development scheme for the path leading to the DSWD COMPLEX. The design phase shall include conducting an appropriate ground survey of the proposed pathway and conducting a slope stability evaluation, which will form the basis of the proposed roadway and slope protection system. The completed structure shall be a pavement which will serve as the main entryway for service and emergency vehicles leading to the COMPLEX. This pavement shall be constructed on a downgraded slope which is protected by the appropriate slope protection system from the base (service gate level) to the arrival point at the ground area of the DSWD premises. The proposed road network system must provide ground support to the expected vehicular traffic loads. In a similar manner, adequate provisions for drainage of surface run-off from the buildings and also be considered in the overall design. The proposed roadway shall have a minimum width of 7.00 m and a length of 106.00 lm. The total construction surface area of the proposed slope protection system as well as the average slope angle and height shall depend on the location of the critical areas, as identified in the slope stability analysis.

The design and specifications shall conform to, but not limited to the following standards set by the: a. National Structural Code of the Philippines (NSCP) 2010 edition; b. The DPWH Standard Specifications for Roads (DPWH Blue Book); and c. Applicable Local Regulations and Ordinances. With respect to the actual construction, applicable rules and regulations prescribed by the following agencies and/or embodied in the following shall be observed: a. Department of Public Works and Highways; b. Department of Environment and Natural Resources. Review the basic design parameters and detailed scope of works. The contractor shall ensure that it has firsthand information on the campus site development plan, construction data of existing buildings, soil survey report, topographic maps and other documents that are readily available from the Owner.

Such will be used to define project design criteria and serve as basis for any changed conditions and establish project cost estimates. Should any of these data and other pertinent data be unavailable, the Contractor shall carry out the needed testing/investigation to complete the needed design data.

II – PROJECT REQUIREMENTS

1. GENERAL

The following are the conditions/design criteria under which the proposed project shall be designed and constructed:

5.1 Project Objectives

5.1.1 Construction of quality **CONSTRUCTION OF ROADWAY AND PARKING AREA** in such a way that it provides the best combination of “quality, functionality, comfort, appearance, environmental sustainability, safety, accessibility for occupants and equipment

5.2 Space Requirements

Space requirements shall be referred from rehabilitation plan.

5.3 Project Process

To implement and complete the design development and construction of the proposed project at a **Guaranteed Maximum Price** as per scope of work described in **Section 4** herein, and as approved by **DSWD FO-X Technical Inspectors.**, the project **Owner** in conjunction with the direct End-Users.

The **Designer/Builder** shall provide for its account all materials, labor, equipment, tools, instruments and appliances needed or necessary to complete the “**Work**”. *Basic and fundamental requirements and/or components required in the TOR but not explicitly shown or whether inadvertently or intentionally missed out in the approved plans and drawings or details shall be provided/installed at no additional costs as if it were incorporated in the approved plans and drawings.*

5.3.1 Development of Theme Concept and Preliminary Scheme, Design of Site Development and its Aesthetic Features which will be finalized for approval together with the detailed Architectural and Engineering Design for review by Engr. Dept. and End-Users.

5.3.2 Detailed Architectural and Engineering Design of the approved Building Plan.

5.3.3 Construction of the proposed Site Development and Building Works and its required Infrastructures and Appurtenances as enumerated in Section 4 of this TOR.

5.3.4 The required design development and construction works shall be completed within a project timeframe of **ONE HUNDRED TWENTY (120)** calendar

days for the scope of works enumerated in **Section 4** of this Performance Specifications and Parameters (TOR).

II. Implementing Phase

The project shall be organized into implementing phases as per location and scope of discipline, namely as:

Phase 1 Design Phase – Architectural and Engineering Design of the storage Building to produce but not limited to the following normal A & E services:

- Architectural Plans
- Civil Works Plans
- Structural Plans
- Electrical Plans
- Sanitary and Plumbing Plans
- Site Development Plans
- Design calculations, analyses and computations as required by the different engineering disciplines to produce the plans and working drawings.
- Construction Specifications
- Detailed Cost Estimates and BOQ

Phase 2 Construction Phase – Construction Implementation

For the design of the said building, the **Designer/Builder** should have a design team of professionals consisting of the design consultants engaged to develop the design of the facility. The following professionals should be included in the Design and Build Team but this does not mean to preclude the inclusion of other professionals should the design of the building warrants the need of their expertise:

Design Phase Key Personnel

Regular consultations with Engineering Dept. shall be done throughout the design phase.

- Principal Architect , Certified practicing Professional with 5 years minimum experience
- Structural Design Engineer with 5 years minimum experience
- Professional Electrical Engineer with 5 years minimum experience
- Senior Sanitary/Environmental Engineer with 5 years minimum experience
- Mechanical Engineer (if appropriate) with 5 years minimum experience
- Landscape Architect (if appropriate) with 5 years minimum experience
- Acoustics Consultant (if appropriate) with 5 years minimum experience
- Certified Network Engineer (if appropriate) with 5 years minimum experience

Construction Phase Key Personnel

The assigned Construction Phase Key Personnel must be at the construction site to oversee and supervise the works in progress as demanded by the construction activities that require their respective expertise and specialties.

- Project Manager with 5 years minimum experience
- Project Engineer with 5 years minimum experience
- Professional Architect with 3years minimum experience
- Materials Engineer, (DPWH Accredited) with 3 years minimum experience
- Professional Mechanical Engineer with 5 years minimum experience
- Professional Electrical Engineer with 5 years minimum experience
- DOLE Accredited Safety Officer with 5 years minimum experience
- Sanitary Engineer/Master Plumber with 3 years minimum experience
- Experienced Construction Foreman with years minimum experience
- CAD Operator/Draftsman with 2 years minimum experience

The **Designer/Builder** should appoint a professional Project Manager. The Project Manager would be responsible for managing the activities of the professional design team, and ultimately for the construction of the project. This person would report directly to the Technical Coordinating Panel and would attend to meetings of the project control group, providing the link between the professional design team and the project control group (the **DSWD FO-X Technical Inspectors**).

In the absence of the Project Manager, the Senior Architect shall assume the role of coordinating all the other professionals involved. Where this is the case, the requirement to report to the **DSWD FO-X Technical Inspectors** should still be maintained.

For the Phase 1 process, the **Designer/Builder** should produce the Detailed Architectural and Engineering Design, Working Drawings, Detailed Project Cost Estimates and Construction Specifications for the building project.

Construction Stage Equipment Required (Minimum)

EQUIPMENT	MINIMUM NUMBER
Utility vehicle, MUV	1
Mini-dump truck	1
Concrete vibrator	2
Concrete mixer, 1-bagger	1
Trowelling machine, 36"	1
Welding machine at least 300 Amps.	6
Pneumatic paint sprayer	4

Air blower	2
Air compressor	2
Jack hammer	2
Power drill	4
Cut-off disc machine	4
Bar bending machine	2
Pipe threader capable up to 6" pipes	1
Pipe bender capable up to 3" pipes	1
Portable disc grinder	6

Specifically, the detailed Architectural and Engineering Design of the building project should address the following design and planning issues involved, such as, but not limited to the following:

1. General design characteristics including integration with other community facilities and adjoining land uses. Detail any public involvement to be incorporated in the design process.
2. A management plan detailing the intended management structure and the intended usage of the various components of the facility.
3. A concept diagram or at least a schedule of the required facility components (rooms /spaces). Indicate the function and required capacity for each component based on expected usage ranges / usage peaks. Where possible, provide floor areas and height limitations. Explain the inter-relationships between the various spaces. Bubble diagrams are a useful way to indicate relationships in terms of juxtaposition and strength.
4. Specific requirements in relation to utilities and services, maintenance of plant and equipment, maintenance access, and external works (e.g. power and water supplies; mechanical and electrical services; security; lighting; signage; landscaping).
5. Environmental issues which need to be addressed (e.g. access before and after construction, traffic; parking; noise; waste; slips, trips and fall protection; visual amenity; provisions to prevent rain drip into building interiors; rain water harvesting; safety and fire protection; natural ventilation; day lighting; prevention of sun glare and unwanted direct sunlight into rooms).

6. The standards of quality and finishes required shall be of high quality and A-1 quality workmanship.
7. Details of any existing facilities to be demolished or upgraded or retrofitted. Indicate any planned /possible future developments.
8. The work to be done in the Design Phase shall consist of the design and plans complete in all details {working drawings, detailed cost estimates and unit prices derivation, design analysis and calculations (i.e. structural, mechanical, hydraulic, sanitary, electrical, other relevant calculations), construction specifications }, of the works at the subject premises, and all work and materials incidental to the Work unless expressly stated to be done by others. *Owner approved working drawings, detailed estimates/BOQ with unit prices, design analyses and calculations (structural, mechanical, hydraulic, sanitary, electrical and other relevant calculations) and construction specifications for materials and workmanship form part of the required submittals for the contractor's application of first billing.*
9. All work shall be done in accordance with the governing Codes and Regulations and with these Specifications, except where same shall conflict with existing Codes, etc., in which the latter shall then govern. The design and specifications of the project shall conform to, but not be limited to the minimum standards set by the following:
 - National Building Code of the Philippines (NBCP)
 - Fire Code of the Philippines
 - Accessibility Law (BP 344)
 - Electrical Code of the Philippines
 - Mechanical Code of the Philippines
 - Sanitary/Plumbing Code of the Philippines
 - Department of Public Works and Highways (DPWH)
 - Applicable Local regulations and Ordinances
 - Applicable International Design and Construction Code Specifications for specialty equipment and products required in the construction plans
10. The requirements in regard to materials and workmanship specify the required standards for the furnishing of all labor, materials, tools, appliances and equipment necessary for the complete installation of the work specified herein and indicated on the drawings. These specifications are intended to provide a broad outline of the required construction/installation, but not intended to include all details of design and construction. *During construction as TCP Inspectors demand it for verification and checking, when details in the contract drawings are insufficient or lacking, shop drawings shall be provided by the Designer/Builder and shall be approved by TCP before execution.* It is mandatory that in the Construction Phase, the **Designer/Builder** shall maintain a CAD operator on site throughout the project duration.
11. The **Designer/Builder** shall adopt his proprietary technique to guarantee the safety and performance of the system in accordance with the concepts and criteria set by these **PERFORMANCE SPECIFICATIONS AND PARAMETERS** otherwise

known as the **TOR**. The **Designer/Builder** must be experienced in the works involved.

12. No consideration will be granted for any alleged misunderstanding on the quality of materials to be furnished or work to be done, it being understood that the submission of a proposal is an Agreement to all items and conditions referred to herein. If specified materials are not locally available, the **Designer/Builder** must immediately place an order as soon as the project is awarded to him. Any exceptions, omissions or substitutions shall be presented in writing with the **Designer/Builder's** proposal. *Where these omissions and errors in the design and construction are discovered earlier or later in the implementation phase, even if they are not shown in the original approved plans but are deemed necessary and basic elements in rendering faithful compliance of the TOR of this Design and Build Contract, they should be provided, corrected and/or rectified at no additional cost to the Owner, as they are deemed obvious and necessary to meet the requirements for serviceability, safety and for weather protection which are of prime intent of this TOR.*
13. The **Designer/Builder**, before commencing work, shall examine the proposed location of the project and all adjoining areas on which this work is in any way dependent for perfect workmanship according to the intent of these specifications and shall report to the **Owner's** representative any conditions which will prevent the **Designer/Builder** from performing the work according to requirements. No waiver of responsibility for defective work will be considered unless notice has been filed at the time the Designer-Builder firm submitted its proposal.
14. **It is the intention of these PERFORMANCE SPECIFICATIONS AND PARAMETERS to call for furnished work tested and ready for operation. Whenever the word "provide" is used, it shall mean "furnish and install, complete and ready for use".** Minor details not usually shown or specified, but necessary for the proper and efficient installation shall be included in the work, the same as if herein specified or shown.
15. **The activities of the Designer/Builder for the detailed design phase would include but not limited to the following:**
 - 15.1 Review the information compiled by DSWD FO X on the preliminary studies, basic design parameters and conceptual layouts.
 - 15.2 Carry out necessary field surveys of the sites for the proposed project. It is envisaged that the survey would include staking, establishing horizontal control points and benchmarks and all necessary cross-sections and topographic surveys of the proposed gates and parking area and/or existing structures. The accuracy of surveys and requirements for closure of horizontal and leveling traverses will be as directed.
 - 15.3 Borings and detailed soil investigations of the proposed sites shall be provided by **DSWD FO-X Technical Inspectors**

- 15.4 Perform Architectural/Structural evaluation and design criteria for the **FACILITIES**. Plans and designs of the building and other facilities should be in accordance with the provisions of the National Building Code, Code of Professional Practice, and other related pertinent codes and laws of the Philippines, or as may be prescribed by **DSWD FO-X Technical Inspectors**.
- 15.5 Carry out Hydrological and Hydraulic studies for all drainage structures either existing or proposed with careful analysis of all available data, including rainfall and flood records, supplemented with details and flood inspection. Catchments areas will be determined from available maps and field investigations. Studies will be made on the existing road side and drainage for adequacy of cross-over culverts and side and run-off ditches. Road and pavement elevations, drainage, channel, side ditches, should be designed adequately to prevent flooding and erosion of the finished roads and ramps. Minimum size of storm drainage to be used shall be 12” regardless of hydraulic calculations yielding smaller size drainage pipe.
- 15.5 Submission of a set of detailed and complete construction plans for the **FACILITIES**.
- 15.5.1 Drawings for submittal shall be one copy (CAD Drawings for the plans, MS Office Documents for the Construction Specifications, Detailed Cost Estimates, and Construction Schedules/Bar Chart with S-Curve) original copy and nine (2) sets of blue prints Design Engineers and Architects.
- 15.5.1 The drawings and the specifications although prepared by the Architect/Engineer, are to become the property of **DSWD FO-X** for whom they were made and who pays for the engineering work involved. These drawings are strictly for use by **DSWD FO-X**. It cannot be used for any other purpose; and if **DSWD FO-X** wants to use it for another project, **DSWD FO-X** shall ask for a written permission from the author/s for a fee mutually agreed by both parties. The original tracing cloth paper of the Approved and Signed Plans and the tracing cloth paper of the Approved and Signed As-Built Plans shall be submitted to **DSWD FO-X**.
- 15.6 Compute all construction quantities for the project to an accuracy of +/- 10% and prepare Bill of Quantities (BOQ) in the manner and form specified by **DSWD FO-X**.
- 15.6 Prepare written detailed specifications for specific items of work or methods of construction, measurement and payment.
- 15.7 Prepare detailed analysis of all application of unit prices using cost indices, rental rates, etc. divided into local and foreign exchange components.

III – DETAILED SCOPE OF WORKS

1. Pre-Planning Phase

The prospective Designer/Builder, by submitting his Proposal, represents that:

- 1.1 He has thoroughly read/examined carefully and understands fully all the proposal documents and his proposal will be in accordance therewith.
- 1.2 His Proposal is based upon the conditions and requirements of the proposal documents and this TOR without exception.
- 1.3 He has visited and inspected the Site of Works and its surroundings and has determined for and satisfied himself as to all matters pertaining to the project, including the location and the nature of the work; constraints and limitations for access and temporary construction facilities; climatic conditions; the nature and condition of the terrain: geological conditions at the site; transportation and communication facilities; the requirement and the availability of materials, labor, water, electric power, the locations and extent of aggregate sources, and other factors that may affect the cost, duration and execution of the work, and that he has determined the general characteristics of the project and the conditions indicated above.
- 1.4 He has acquainted and familiarized himself with all conditions, local or otherwise, affecting the carrying out of the contract work and has arrived at an estimate of the facilities available and the facilities needed for the project.
- 1.5 He has familiarized himself with all laws, decrees, regulations of the Philippines, local regulations and ordinances including green building design concept and construction requirements, which may affect or apply to the operations and activities of the contractor.

2. Survey and Studies

2.1 Survey of Existing Utilities

- i. The prospective **Designer/Builder** is expected to conduct an actual site survey of the project area to identify/verify preliminarily, the metes and bounds of the proposed project including easements and property lines. In the process, he shall be able to familiarize himself with the site and nearby occupancy.
- ii. It is also expected that the prospective **Designer/Builder** shall familiarize himself with existing relevant materials and literature of the project, to enable him to come up with an intelligent proposal.
- iii. Determine existing and proposed infrastructure, facilities, utilities, etc., which may have a bearing on the planning and design exercise. **DSWD FO-X**, through the

DSWD FO-X Technical Inspectors shall identify/locate the existing utilities at the site, namely:

- a. Electrical Power Supply System (underground and/or overhead)
- b. Water Supply System
- c. Sewer and Storm Drainage System
- d. Telephone Lines (underground and/or overhead)

3. Planning/Design Phase

3.1 Architectural/Engineering Design Requirements/Considerations:

- a. The detailed design shall conform to the general standards adopted by the National Building Code of the Philippines, Electrical Code of the Philippines, Mechanical Code of the Philippines, Plumbing/Sanitary Code of the Philippines, Fire Code of the Philippines, Accessibility Law (BP 344), local regulations and ordinances, incorporating green building design concepts, as a minimum, provisions for protection of the building and occupants from the elements of the weather and environmental effects.
- b. All design considerations/assumptions shall be based on the actual site condition, soil boring data, and topographic survey, prevailing wind direction and solar orientation. The technical drawings and specifications shall clearly indicate all the details required to ascertain the care and thoroughness devoted in the preparation, accuracy and technical soundness, and their usefulness as a guide to project implementation. When details shown in the working drawings are inadequate for implementation, shop drawings must be furnished from time to time as needed to guide in the construction and/or installation. All shop drawings and drawings marked by designer for implementation shall bear the approval of TCP before implementation.

3.2 Site Grading and Clearing

- c. Site clearing and relocation of existing structures (if any) shall be taken into consideration.
- d. All existing and design elevation shall be indicated in the plans complete with established horizontal and vertical survey references.
- e. Preservation of existing site vegetation and other endangered plant and trees present at site shall be considered in the design of the site development plan.

3.3 Drainage and Sewerage System

- a. The drainage layout shall show all the required information such as direction of flow, catch basins, manhole to manhole distances and sizes of lines, invert elevation of manholes/canals, location of outfalls, etc. Minimum size of storm lines shall be 12" irrespective of the results of hydraulic calculations yielding smaller values.

3.4 Water Supply System

- a. The Designer/Builder shall carry out a detailed design for the water supply of the project. The design should be on the basis of the source and volume of water supply, water consumption (domestic and fire protection system), piping network, and conveyance in accordance with the applicable laws, rules and regulations governing health, safety and sanitation.
- b. Water supply shall be sourced from the existing water concessionaire at the area.
- c. The Designer/Builder shall carry out detailed design for Rain Water Collection System to be utilized as secondary water supply for flushing of toilets and gardening to reduce at least 60 % potable water consumption. The Rain Water Collection System shall be cascade type wherein the rain tank on the topmost floor should be sized for optimize collection of rain water to be feed to lower floors through gravity. Excess rain shall be routed to the ground cistern of optimized volume commensurate to the amount of water harvested from roof decks to resupply the rain tank during dry weather. Two cisterns shall be constructed. One for the rain water collection and the other for the local waterworks water supply.

3.5 Power Supply and Distribution

- a. The contractor shall assist **DSWD FO-X Technical Inspectors** in coordinating with the local electrical company to ensure that the project shall have an ample electrical power supply.

4. Material Specifications

5. Architectural and Engineering Designs

5.1 Architectural Design

- a. The building should be designed for mechanical, natural or combined ventilation.
- b. The roofing shall be long span and pre-painted sheet for general roofing requirements, at least 4mm thick with imbedded insulated P.E. coating impact resistant translucent double sided UV stabilized solid flat polycarbonate sheet roofing light penetration and day lighting.
- c. The prospective bidder shall prepare the Preliminary Architectural Plans incorporating sustainability and green building design concepts, in compliance and in accordance with the requirements of the National Building Code of the Philippines, Accessibility Law (BP 344) including all other applicable laws and local ordinances.
- d. *The Preliminary Architectural and Engineering Plans to be submitted in the bid opening should be sufficient and adequate enough such that it can serve for the following purposes:*
 1. Basis for the **DSWD FO-X Technical Inspectors** for determining the acceptability of the bid based on this PERFORMANCE SPECIFICATIONS AND PARAMETERS and ITB. The Architectural and Engineering Plans in the bid submittals are not necessarily detailed and complete but should show the general layout, circulation, framing layouts, materials and finishes to be applied, locations and classifications of utilities and the building electrical and mechanical services, etc. These submitted plans are for bid purposes only and should be sufficient

enough such that the bidder can intelligently make his BOQ to arrive his bid cost. The final detailed Architectural and Engineering Plans are to be submitted later when the contract is awarded to the winning responsive bid. When this final detailed Architectural and Engineering Plans are approved by the Owner, it become the basis for the execution of the Construction Phase of this Design & Build Contract

2. Enable the Designer/Builder to intelligently quote for the schedule of bid prices, considering due allowances for cost calculations as enumerated in Clause 9.0 of this PERFORMANCE SPECIFICATIONS AND PARAMETERS. The Designer/Builder's total Bid Price quoted shall be taken as the Designer/Builder's Guaranteed Maximum Price (GMP) for the Project.

SUBMITTALS (at suitable scale on A3 whiteprint paper minimum size):

1. Site Development Plan
 - a. Vicinity Map
2. Perspective
3. Floor Plans and furniture layout
4. Elevation Plans
 - a. Front Elevation
 - b. Rear Elevation
 - c. Right Elevation
 - d. Left Elevation
5. Section Plan
 - a. Longitudinal Section
 - b. Cross Section
6. Doors & Window Schedule
7. Doors & Window Schedule
8. Architectural detail of stairs and ramp for the handicapped
9. Reflected Ceiling Plans
10. Schedule of Finishes for floors, walls and ceiling

5.2 Structural Design

- a. The **Designer/Builder** shall prepare the necessary structural analysis/calculation and design of the structural members of the building component in accordance with the National Building Code of the Philippines with its referral codes such as the National Structural Code of the Philippines, etc. The design for the structure shall take into account, among other things, the seismic requirements of the area to determine the optimum safety of the whole structure and to minimize possible earthquake damage.
- b. On the basis of the data obtained from the detailed site investigations, topographical/soil and survey, geotechnical engineering, foundation investigation, material testing, survey of existing site conditions, the seismic requirements of the area, the load requirements of the building and other investigation required to obtain

the data necessary to ensure the safety of the structure, the proponent shall prepare the preliminary structural design plans of the structure.

SUBMITTALS (at suitable scale on A3 whiteprint paper minimum size)

1. Structural Design Criteria and Design Notes
2. Foundation Plan
3. Floor and roof deck framing plans
4. Schedule of slab, beams and girders
5. Schedule of columns
6. Schedule of footings
7. Structural details of stairs
8. Roof framing plan
9. Schedule and details of trusses

5.3 Sanitary/Plumbing Design

- A. General
 - a. The detailed design shall conform to the general standards adopted by the Sanitary & Plumbing Code of the Philippines and other pertinent laws and ordinances.
 - b. All design considerations/assumptions shall be based on the results of the technical studies, detailed analyses, and design computations.
 - c. The technical drawings and specifications shall clearly indicate all the details required to ascertain the care and thoroughness devoted in the preparation of the drawings.
- B. Drainage and Sewerage
 - a. Drainage and sewerage shall be underground.
 - b. The drainage layout shall show all the required information such as direction of flow, manhole-to-manhole distances, and sizes of lines, manholes/canals, location of outfalls, etc.
 - c. Design of sewerage system shall be based on the total requirement of the building.

SUBMITTALS (at suitable scale on A3 whiteprint paper minimum size):

1. General Notes
2. Legend & Symbols
3. Sewer, vent and storm drainage layout
4. Enlarged toilet plan for common and handicapped toilets
5. Isometric Diagram
6. Miscellaneous details
7. Drainage System
8. Septic tank system plans and details
9. Water Supply and Distribution System

- c.1 The Proponent shall carry out a preliminary detailed design for the water supply of the project. The design should be on the basis of the source and volume of water supply, water consumption (domestic & fire protection system), piping network, and conveyance in accordance with the applicable laws, rules and regulations governing health, safety and sanitation.
- c.2 Water supply will be sourced from the existing water concessioner at the area.
- c.3 As sustainable feature of green building, the proponent shall also carry out a detailed design for RainWater Collection System as secondary water supply to be utilized for flushing of toilets and gardening to reduce at least 60 % of potable water usage. A first flush device must be provided to exclude the first 5 minutes of rainfall to enter into the rainwater cistern.

SUBMITTALS (at suitable scale on A3 whiteprint paper minimum size):

1. General Notes
2. Legend & Symbols
3. Water Line layout
4. Water Line Isometric Diagram

5.3 Electrical Design

- a. The prospective bidder shall prepare a preliminary design plans for the electrical and power supply system of the building in accordance with the Electrical Code of the Philippines, Fire Code of the Philippines, National Building Code of the Philippines and other relevant laws and ordinances
- b. The prospective bidder shall prepare a design for the electrical and power supply system and telephone system considering ease of maintenance and prevention of illegal connections.
- c. Electrical supply shall be sourced from the local electrical utility. Minimum wire sizes shall be as follows: 3.5mm² (#12) for lighting circuits and 5.5mm² (#10) for power and outlets circuits.

SUBMITTALS (at suitable scale on 20" x 30" whiteprint paper minimum size):

1. Power Riser Diagram
2. Power Layout System
3. Lighting Layout System
4. Fire Alarm System
5. Grounding System
6. Load Schedules
7. Others as applicable

Other Requirements

1. Technical Specifications
2. Structural Design Analysis and computation
3. Narrative description of all green features and strategies used in the design of the building to comply requirements of sustainability and green building design best practices. These green building features must be clearly shown and/or indicated in the submitted plans.

6. Final Design and Construction Plans

Upon award of contract, the contractor shall comply the following;

1. Within fifteen (15) days upon the official start of the project, the Designers shall meet with **DSWD FO-X Technical Inspectors** and the End-Users for an Inception Meeting to discuss the design issues and concerns to be address in the making of the final plans and designs.
2. Prepare final draft of Architectural and Engineering Design Plans incorporating all design refinements and revisions based on project requirements and the issues and concerns raised in the Inception Meeting or as may be required by **DSWD FO-X** within the scope of design parameters/requirements/considerations set forth in the PERFORMANCE SPECIFICATIONS (TOR) at no additional cost to **DSWD FO-X**.
3. The final draft of design plans and specification shall be submitted to the **DSWD FO-X Technical Inspectors** for assessment/evaluation and review as to compliance with the requirements of the PERFORMANCE SPECIFICATIONS and Standards Facilities. Such findings/recommendation of the Technical Coordinating Panel shall be incorporated in the final plans at no additional cost to **DSWD FO-X**.
4. Submit to the **DSWD FO-X** the Final Architectural and Engineering Design Plans and Specifications duly signed and sealed by the concerned Professional Architect and Engineers incorporating all the necessary revisions and refinements within 30 calendar days after the effectivity of the Design & Build contract for approval. The Final Architectural and Engineering Plans and Specifications are mandatory requirements for the first billing. No release of first billing payment if the Final Architectural and Engineering Plans are not complete.

7. Quantity Calculation

The Designer/Builder shall submit the quantities of the different types of works to be carried out. In particular, the quantities of each work item shall be calculated and a bill of quantities shall be prepared to be supported with detailed cost estimates based on the scope of work as defined under **SCC Clause 1.30** of this Bid Documents which shall include:

Upon award of contract, the contractor shall comply the following;

1. Architectural & Engineering Design Services.

1.1 Direct Costs

- a. General Requirements such as Temporary Facilities, Site protection requirements (i.e. temporary services, temporary fencing, temporary access, etc.);
- b. Construction Safety, Health and Safety Requirements;
- c. Cost of materials (cost of sources, transport, handling, storage, miscellaneous expenses and allowances for wastage);
- d. Cost of construction plant and equipment, including depreciation or rental rates, wages of operators, fuel, oil lubricants and maintenance;
- e. Cost of labor, including salaries, wages, cost of living allowance and all fringe benefits;
- f. All other incidental expenses necessary for the construction of the project.

1.2 Indirect Cost (For Item 2 above only)

- a. Overheads;
- b. Contingencies ;
- c. Miscellaneous ;
- d. Profit;
- e. Insurances and Bonds Premiums
- f. All applicable Taxes

8. Construction Documentation Phase

8.1 The winning Designer/Builder, hereinafter referred to as the Contractor shall, upon receipt of the Notice to Proceed (NTP);

- a. Post a contract performance security.
- b. Secure a Contractor's All Risk Insurance (CARI) covering 100% of the infrastructure cost, from the GSIS General Insurance Fund or any private bonding corporation acceptable to **DSWD FO-X** and maintains such insurance coverage up to the date of the Final Acceptance Of the project. Such insurance shall be submitted to **DSWD FO-X** together with the Official Receipt of Payment of premium evidencing enforceability.
- c. Construction Schedule (PERT/CPM, Gantt Chart and S-Curve) including Architectural and Engineering Design Plans submission which shall not exceed 15 calendar days.
- d. Other requirements that may be required by **DSWD FO-X**.

8.2 The Contractor, upon compliance with the foregoing, shall execute the Design and Build Contract with the REGIONAL DIRECTOR of **DSWD FO-X**, which is the Head of the Procuring Entity.

9. Construction Phase

9.1 The Designer-Builder shall carry out and complete all items of work within the scope of works in accordance with the approved plans and specifications.

9.2 The Designer/Builder shall prepare approved major modifications/changes in design, if any, during the construction implementation.

9.3 The Designer/Builder shall prepare daily activity reports, weekly and monthly accomplishment reports supported with progress photographs and S-Curves to monitor actual progress status report and to be used as basis for progress billing.

9.4 **Permits and Clearances.** The Contractor shall, upon authorization of L **DSWD FO-X**, make representations with the government agencies concerned to expedite the processing of the necessary permits and certificates such as the following:

- a. Building/Electrical/Sanitary Permits
- b. Occupancy permit
- c. All other permits/clearances as may be required for the construction.

Even though it is exempted from the Building Permit Fees as a government institution, the Designer/Builder shall anticipate some other permits and documents that may be required by the Building Official of such as the Fire Department Fee, etc. **DSWD FO-X** will assist the Contractor to facilitate the processing of the building permit application. Final billing of the Contractor will not be released unless the approved original copy of the Certificate of Occupancy is submitted to **DSWD FO-X**.

9.5 **Temporary Structures & Facilities.** The Contractor shall provide and maintain the following:

- a. Temporary office and/or quarters for the Contractor's project team personnel with water, light, telephone and toilet facilities.
- b. Temporary bunkhouse/quarters for the contractor's workforce complete with toilet and bath facilities. The Contractor shall submit to water meter and electric meter for proper recording and accounting of the water and power consumption of the Contractor during the project contract period.

9.6 **Mobilization.** The Contractor shall mobilize all the required project team personnel, equipment, tools, and manpower with the required skills and in sufficient number as may be necessary for his efficient undertaking of the project.

9.7 **Construction Stage.** As a rule, contract implementation guidelines for procurement of infrastructure projects shall comply with Annex "E" of IRR, RA 9184. The following provisions shall supplement these procedures:

- a. No works shall commence unless the contractor has submitted the prescribed documentary requirements and **DSWD FO-X** has given written approval. Work execution shall be in accordance with reviewed and approved documents.
- b. The contractor shall be responsible for obtaining all necessary information as to risks, contingencies and other circumstances which may affect the works and

shall prepare and submit all necessary documents specified by **DSWD FO-X** to meet all regulatory approvals as specified in the contract documents.

- c. The contractor shall submit a *Detailed Program of Works* and *Inception Report* within fifteen (15) calendar days after the issuance of the Notice to Proceed for approval by the procuring entity that shall include, among others:
 1. The order in which it intends to carry out the work including anticipated timing for each stage or design/detailed engineering and construction;
 2. Periods for review of specific outputs and any other submissions and approvals;
 3. Sequence of timing for inspection and tests;
 4. General description of the design and construction methods to be adopted;
 5. Number of personnel to be assigned for each stage of the work;
 6. List of equipment required on site for each stage of the work; and
 7. Description of the quality control system to be utilized for the project.
- d. *As a Design and Build project, errors and omissions in the designs are the responsibility of the Design-and-Build Contractor. Wherefore any errors, omissions, inconsistencies, inadequacies, non-functionality or failures submitted by the Contractor that do not comply with the requirements and objectives of the TOR shall be rectified, corrected, resubmitted and reviewed at the Contractor's cost. If the Contractor wishes to modify any design or document which has been previously submitted, reviewed and approved, the Contractor shall notify **DSWD FO-X** within a reasonable period of time and shall shoulder the cost of such changes*
- e. As a rule, changes in design and construction requirements shall be limited only to those that have not been anticipated in the contract signing and approval. The following guidelines shall govern approval for change or variation order:
 1. Change Orders resulting from design errors, omissions, inconsistencies, non-functionality or non-conformance with the performance specifications and parameters and the contract documents by the Contractor shall be implemented by the Contractor at no additional cost to **DSWD FO-X**.
 2. The contract documents shall include the manner and schedule of payment specifying the estimated contract amount and installments in which the contract will be paid.
 3. **DSWD FO-X** shall define the quality control procedures for the design and construction in accordance with the Government Guidelines and shall issue the proper certificates of acceptance for sections of the works or whole of the works as provided for in the contract documents.
 4. The Contractor shall provide all necessary equipment, personnel, instruments, documents and others to carry out specified tests.

5. This design and build project shall have minimum Defects Liability period of one (1) year contract completion or as provided for in the contract documents. This is without prejudice to the liabilities imposed upon the engineer/architect who draw up the plans and specification for a building sanctioned under Section 1723 of the New Civil Code of the Philippines.
6. The Contractor shall be held liable for design and structural defects and/or failure of the completed project within the warranty period of 15 years. If the building is damaged or collapsed because of these design and structural defects, the Contractor shall repair and/or retrofit the building at no additional cost to the Owner provided that the failure or collapse occurred within the warranty period.

9.8 The Contractor shall commence work within (7) calendar days from the date of receipt of Notice-to-Proceed. The design and construction of the project shall be completed within ONE HUNDRED TWENTY (120) calendar days from the date of effectivity of the Agreement.

9.9 As-built Plans.

The contractor shall cause the preparation and submission of As-built Plans duly signed and sealed by all concerned parties involved in the construction in the same sheet size and scale as the original drawings in four (4) sets of whiteprint copy and one (1) electronic/reproducible copy. These As-built Plans must be a faithful reproduction/layout of what were actually provided and/or installed in the actual construction of the project. These four (4) whiteprint copy is for **DSWD FO-X** only. Additional whiteprint copies of the As-built plans may be required by the Building Official for obtaining Certificate of Occupancy and it is the responsibility of the Contractor to provide the Building Official the needed documents.

10. Reports to be Submitted

10.1 The Designer/Builder shall submit five (5) hard copies and one (1) CD copy of the following reports and document, all in English, with a general format and content properly bound with title cover acceptable to **DSWD FO-X**. These reports shall be submitted in accordance with the schedule included in the technical proposal approved by **DSWD FO-X**:

10.1.1 Consultant's Comments. Covering the **DSWD FO-X** preliminary studies and basic design criteria (Inception Report) to be submitted within fifteen (15) days after the issuance of Notice to Proceed.

10.1.2 Survey Data Report. Complete data for site, topographic, geotechnical, and geological surveys, coordinates and elevation references, power supply and other requirements as may be deemed necessary.

10.1.3 Geo-Technical Report. Summarizing the results, analysis and evaluation of the soils investigation reports prepared by other party for the building and other facilities.

10.1.4 Hydrology Report. Summarizing the hydrological studies, their locations, conclusions drawn from studies, and design data for culverts, drainage channels, and slope protection works.

10.1.5 Quantity Calculations. Complete calculations for every item of construction work specified in the Bill of Quantities.

10.1.6 Design Report. Summarizing the basis for the design presented and including all design calculations properly indexed.

10.1.7 Unit Price Analysis. Showing sources of data and all calculations made in determining the unit price of each item of work, including profit factor, overhead, contractor's tax, etc.

10.1.8 Drawings Submittal. Submittal shall include topographic and hydrological surveys and design drawings such as site development, architectural, civil, structural, electrical, sanitary, and plumbing plans.

10.2 The Contractor shall be obliged to the submission and deliberation of the following reports:

10.2.1 Inception Report – to be submitted within fifteen (15) days after the official start of the project in five (5) bounded copies and one (1) CD copy.

10.2.2 Interim Progress/Status Report – to be submitted during request for progress billing.

10.2.3 Draft Final Report – to be submitted on the seventh week in six (6) bounded copies and one (1) CD copy.

10.2.4 Final Report – to be submitted one (1) week after the return of the draft final report with comments, recommendations and conclusions, as well as compilation of reports previously submitted, in six (6) bounded copies and one (1) CD copy.

11. Data and Local Services to be provided by DSWD FO-X

11.1 **DSWD FO-X** will provide the Design/Build Proponent with:

- 11.1.1 Basic design guidelines and criteria/standards;
- 11.1.2 **DSWD FO-X** Facilities Standards;
- 11.1.3 Initial Schematic Plans;

12. Bid Evaluation and Selection Process

The Design/Build Proposal shall be evaluated using a Two-Step Procedure:

12.1 First-Step Procedure: The first step of the evaluation shall involve the review of the preliminary conceptual designs and track record submitted by the contractor as indicated in the bid documents using a non-discretionary “pass/fail” criteria that involve compliance with the following requirements:

- 12.1.1 Adherence of preliminary design plans to the required performance specifications and parameters and degree of details.
- 12.1.2 Concept of approach and methodology for detailed engineering, design and construction with emphasis on the clarity, feasibility, innovativeness and comprehensiveness of the plan of approach, and the quality of interpretation of project problems, risks, and suggested solutions; and
- 12.1.3 Quality of personnel to be assigned to the project which covers suitability of key staff to perform the duties of the particular assignments and general qualifications and competence including education and training of the key staff.

12.2 Second-Step Procedure: Only those bids that passed the above criteria shall be subjected to the second step of evaluation.

- 12.2.1 The **DSWD FO-X** BAC shall open the financial proposal of each “passed” bidder and shall obtain the correct calculated prices. The financial bids as so calculated shall be ranked, in ascending order, from lowest to highest. The responsive bid with the lowest price shall be identified as the Lowest Calculated Bid (LCB).

13. Deferred Items

Some items are deferred due to fund limitation but they are to be included and part of the final submittals of the final plans and drawings including the specifications, but place in a separate BOQ under the heading “Deferred Cost Items for Future Construction”.

14. Schedule of Deliverables

In order to clarify the sequence of activities and deliverables under this Terms of Reference (TOR), reference must be made to the chart below after the contract is awarded.

Section VII. Drawings

|

DSWD-FOX

LOT 1: PROPOSED ECUMINICAL CHAPEL (DESIGN AND BUILD)(RRCY COMPLEX)

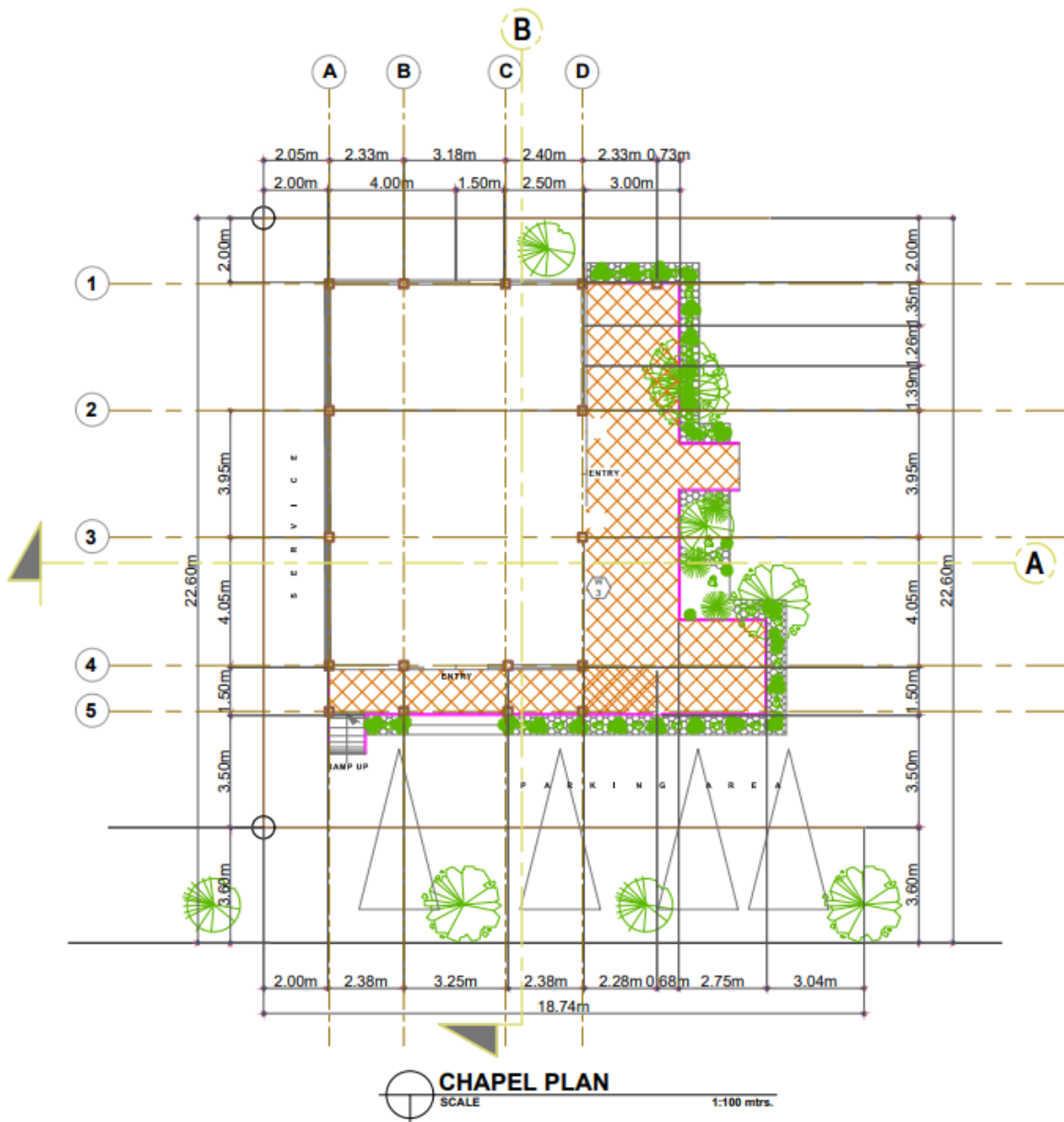

**LOT 2: MAJOR REPAIR OF THE HOMELIFE BUILDING ROOF (DESIGN & BUILD)
(RRCY COMPLEX)**



SITE DEVELOPMENT PLAN

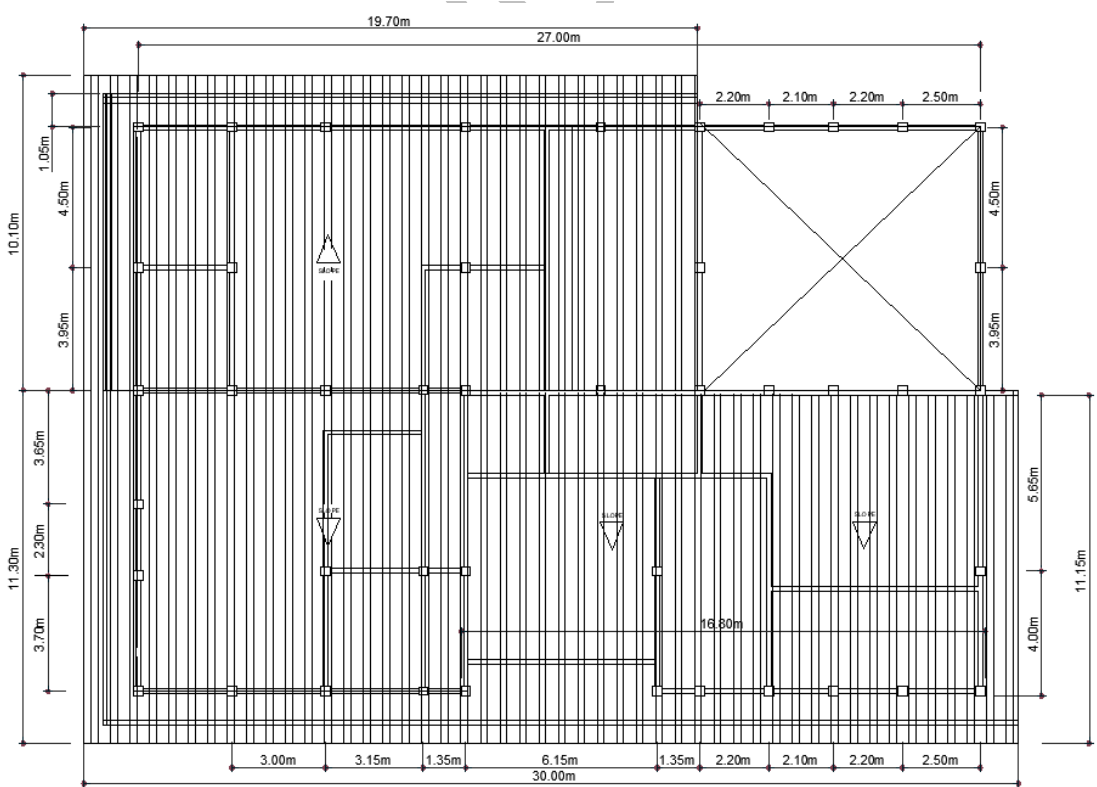

ROOF PLAN

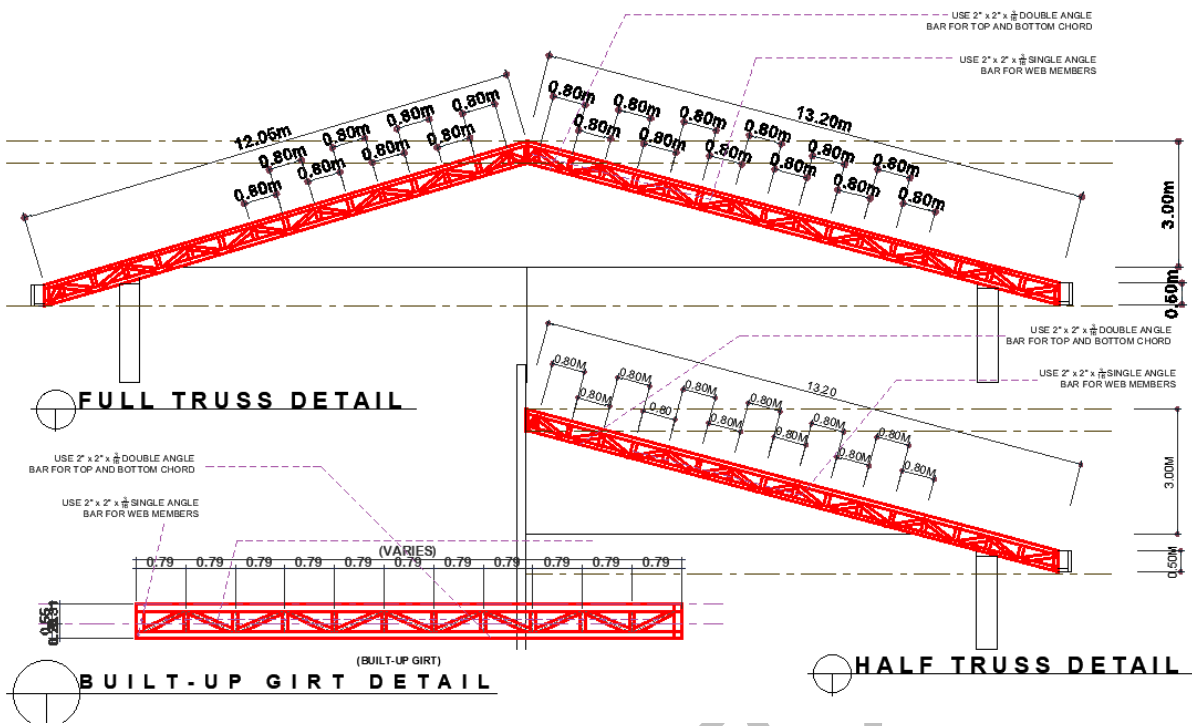

DSWD-FC

LOT 3: REHABILITATION OF BAHAY SILUNGAN BUILDING AND INSTALLATION OF FIRE ALARM AND DETECTION SYSTEM WITH FDAS (DESIGN & BUILD)

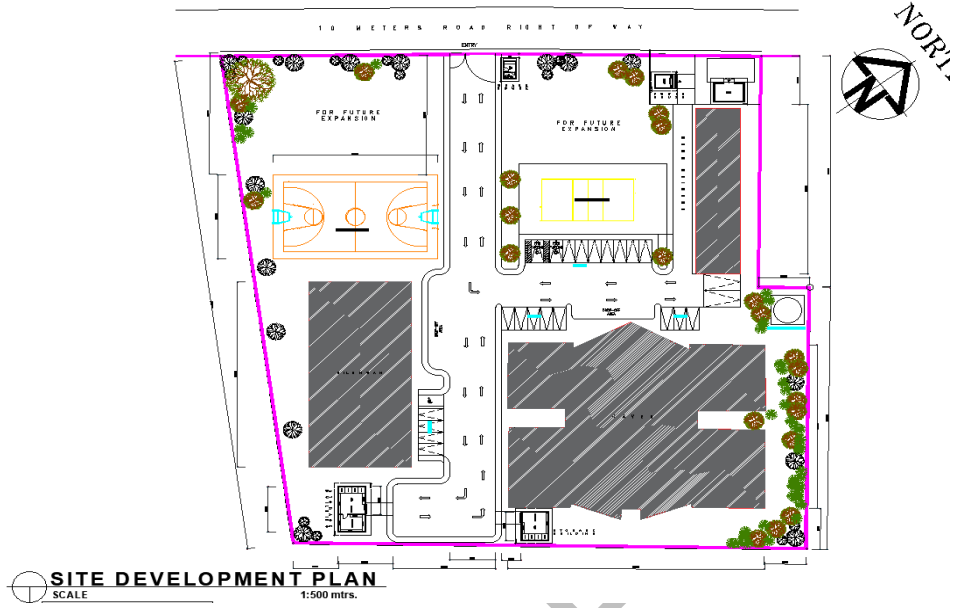

SITE DEVELOPMENT PLAN
SCALE 1:500 mtrs.

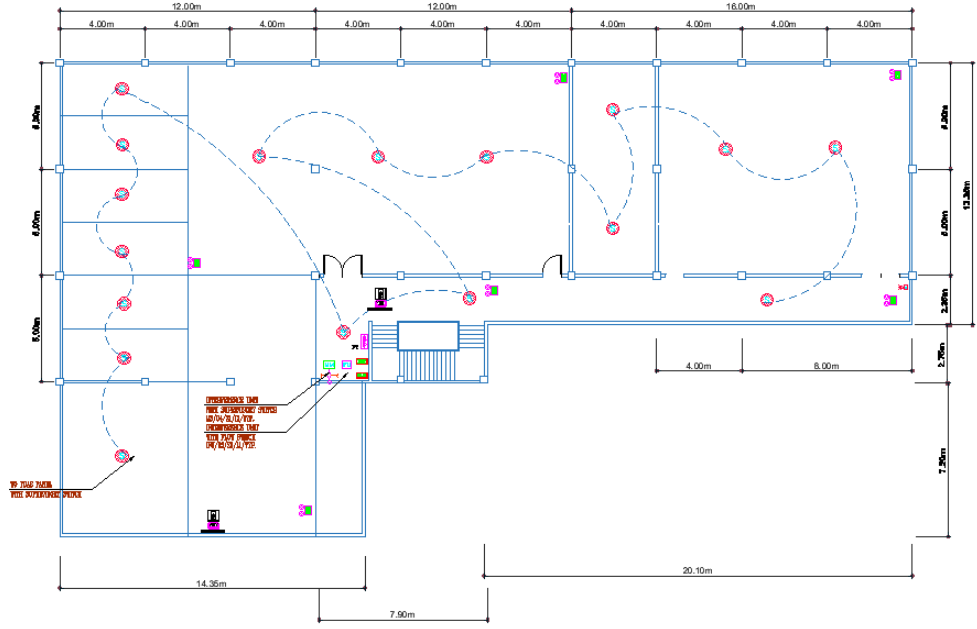

GROUND FLOOR FDAS LAYOUT PLAN
SCALE 1:500 mtrs.

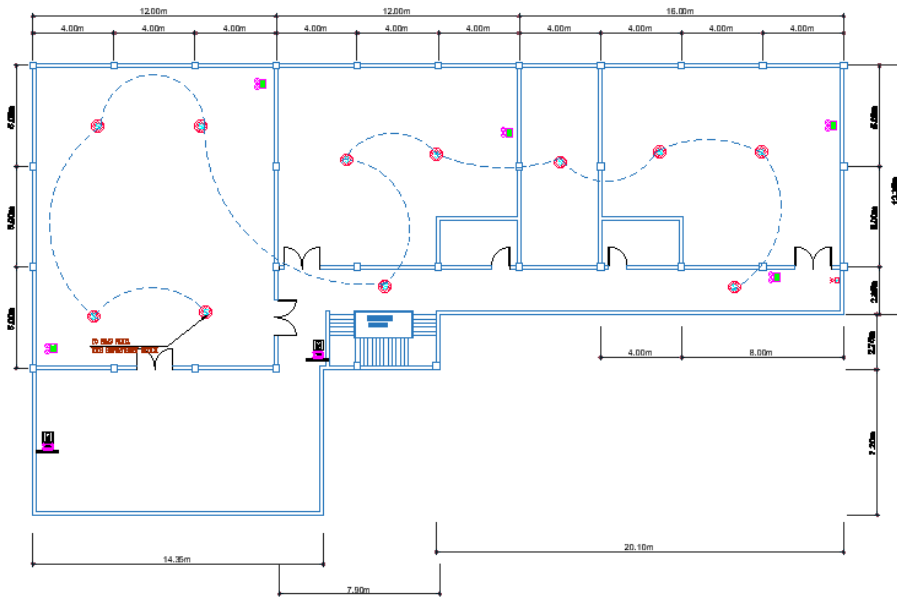

SECOND FLOOR FDAS LAYOUT PLAN
 SCALE 1:500 mtrs.

DSWD-1

**LOT 4: CONSTRUCTION OF STORAGE WAREHOUSE FOR BAHAY SILUNGAN
(DESIGN & BUILD)**

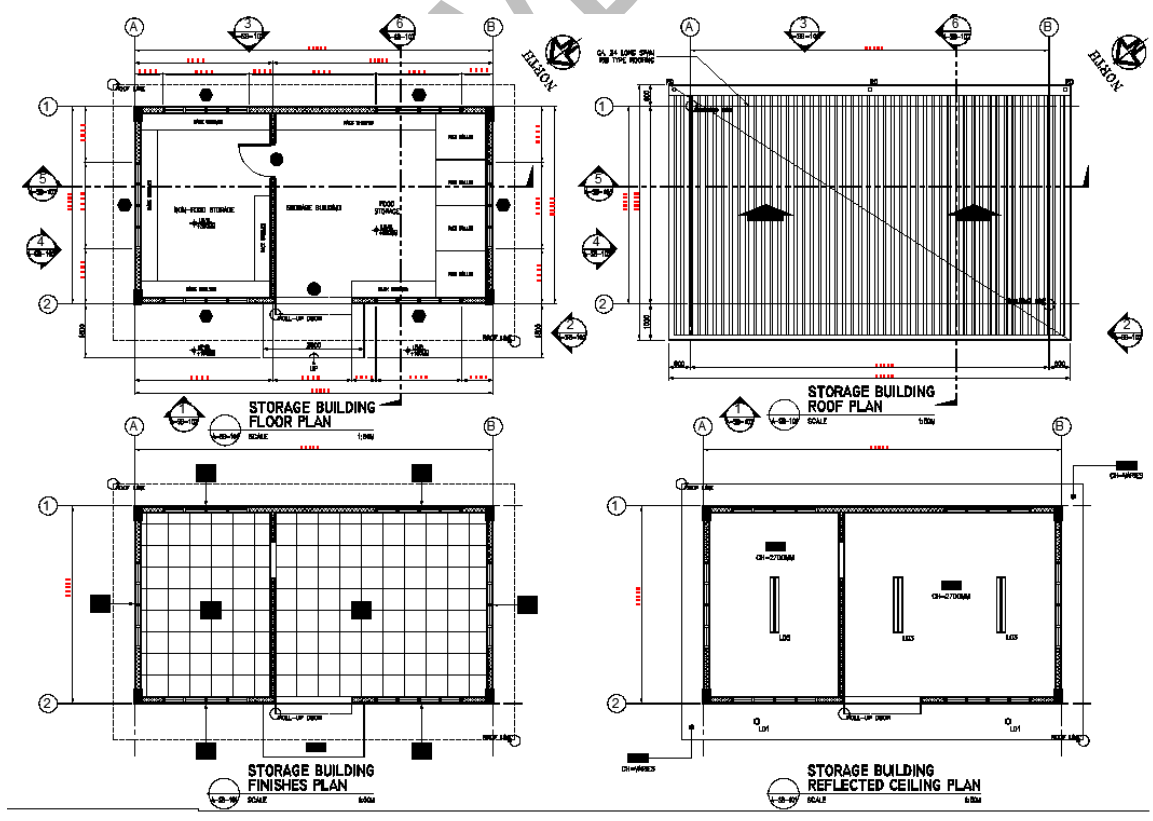
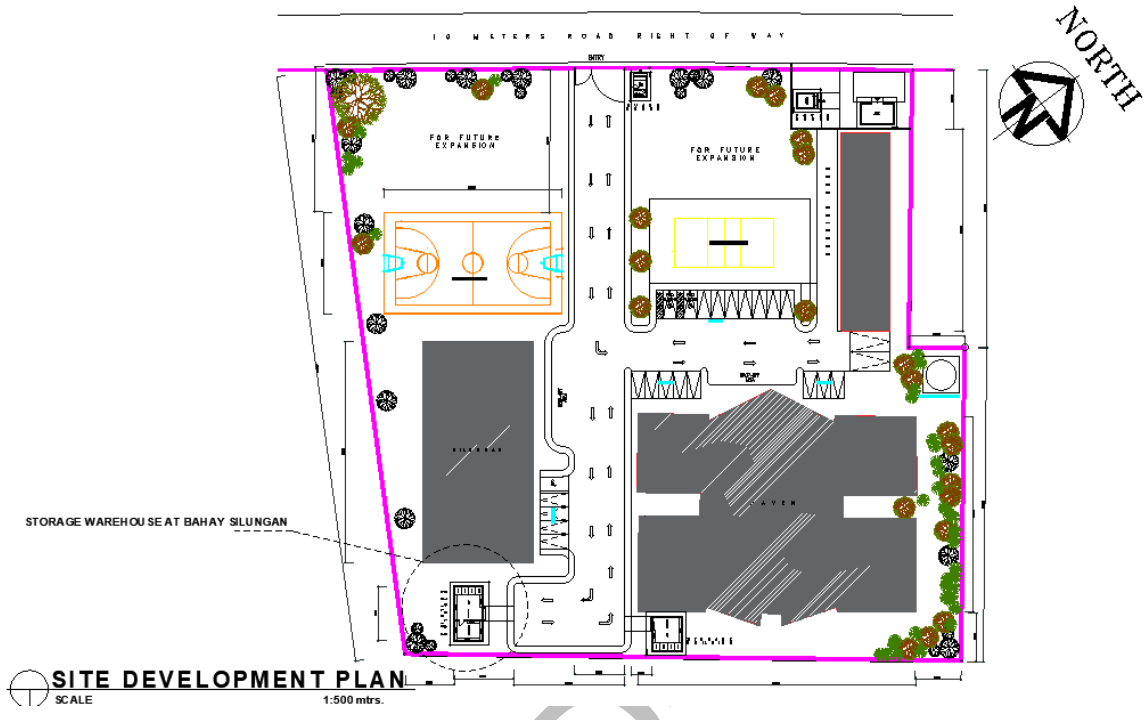

LOT 5: CONSTRUCTION OF PUMPHOUSE WITH EQUIPMENT (DESIGN AND BUILD)

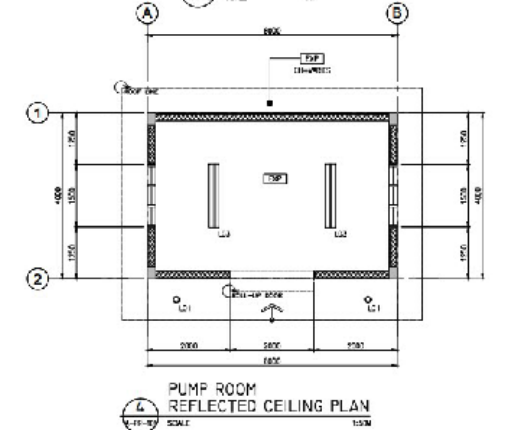
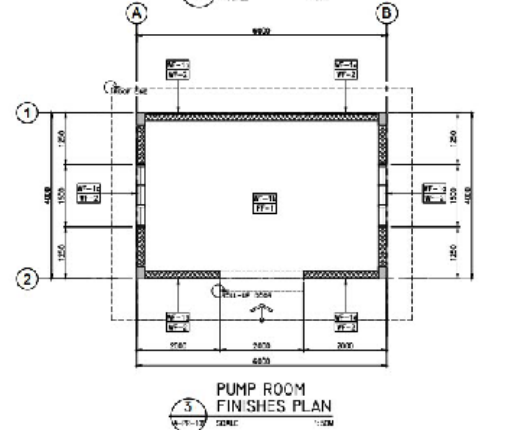
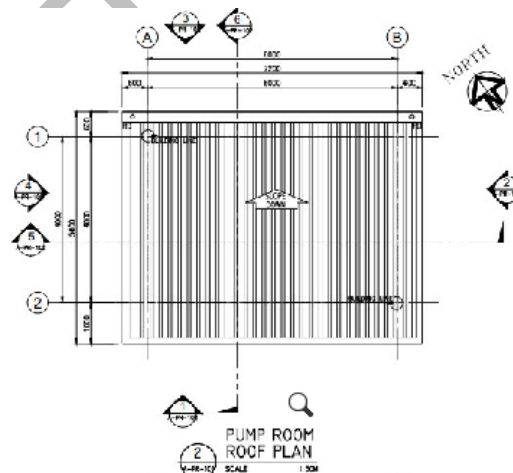
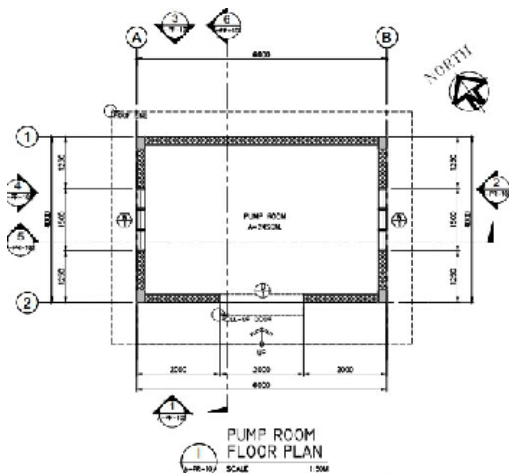
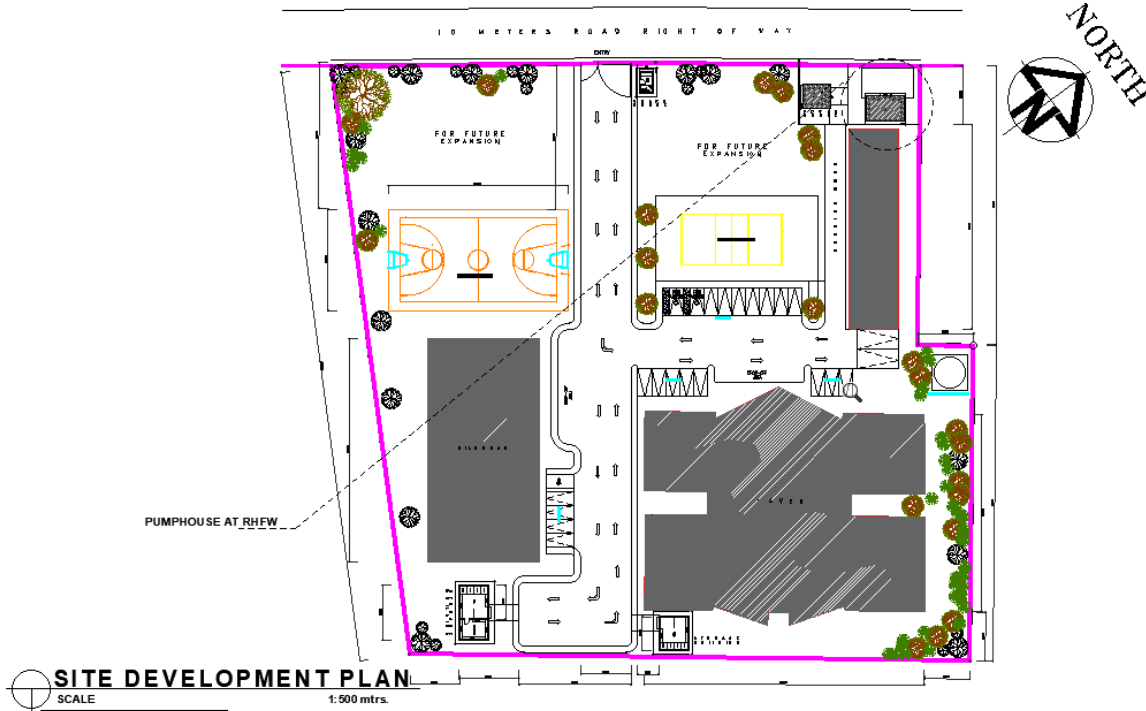

LOT 6: CONSTRUCTION OF POWERHOUSE WITH EQUIPMENT (DESIGN AND BUILD)

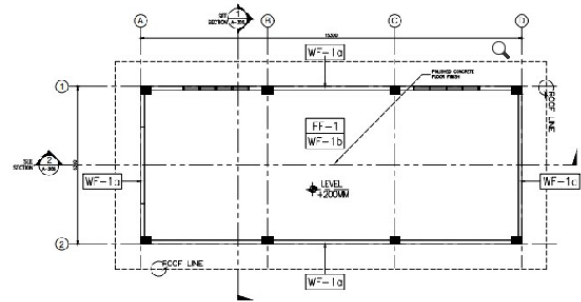
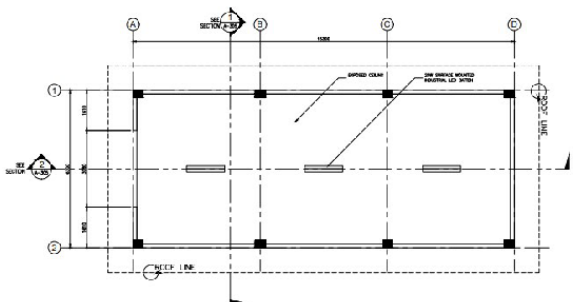
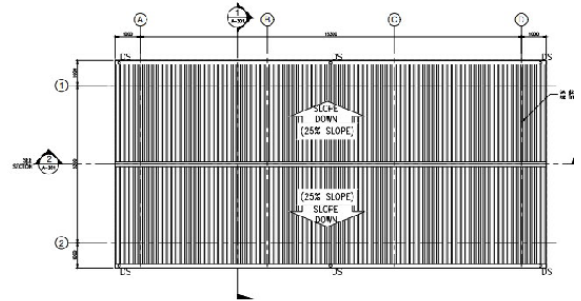
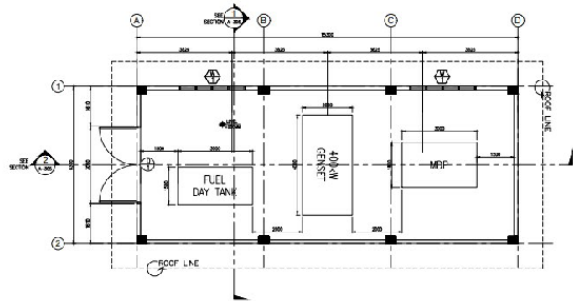
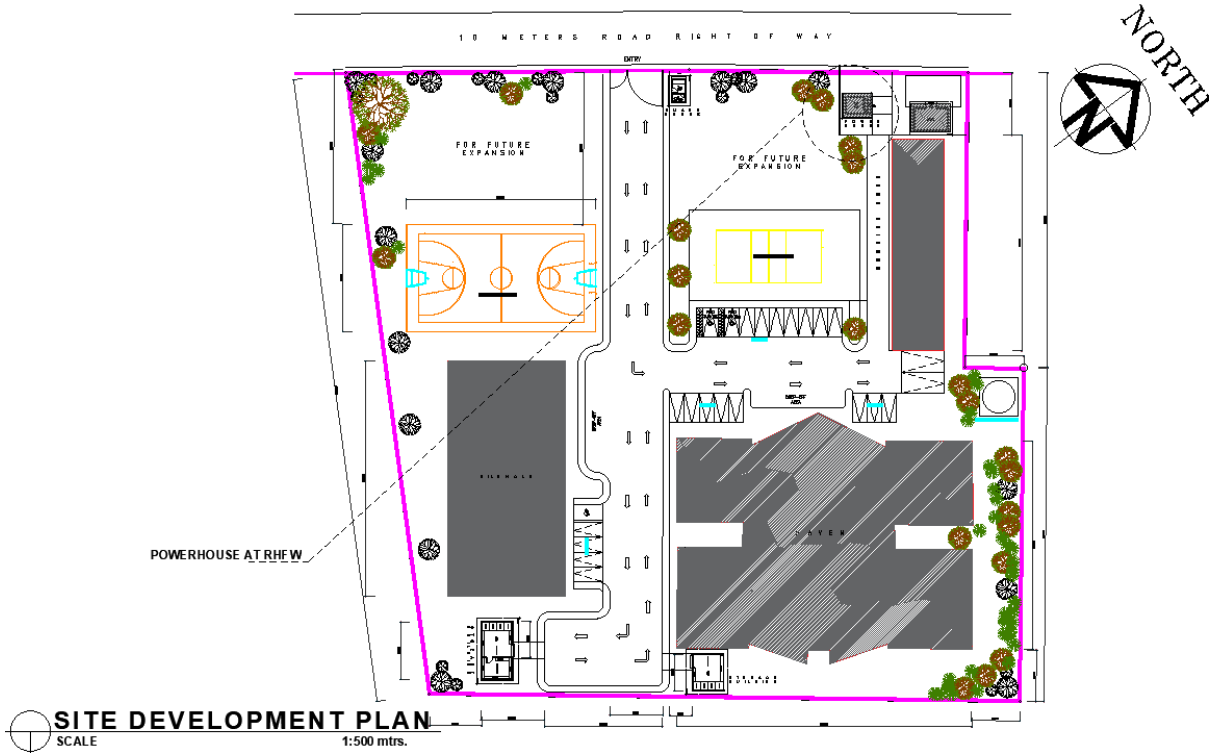

**LOT 7: CONSTRUCTION OF STORAGE WAREHOUSE FOR REGIONAL HAVEN
FOR WOMEN (DESIGN & BUILD)**

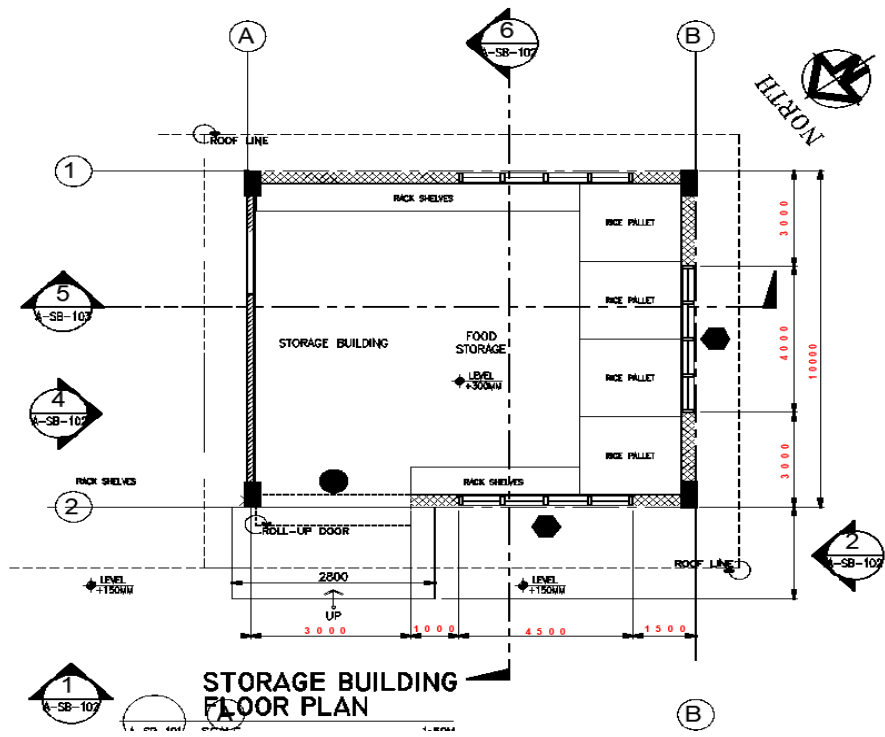
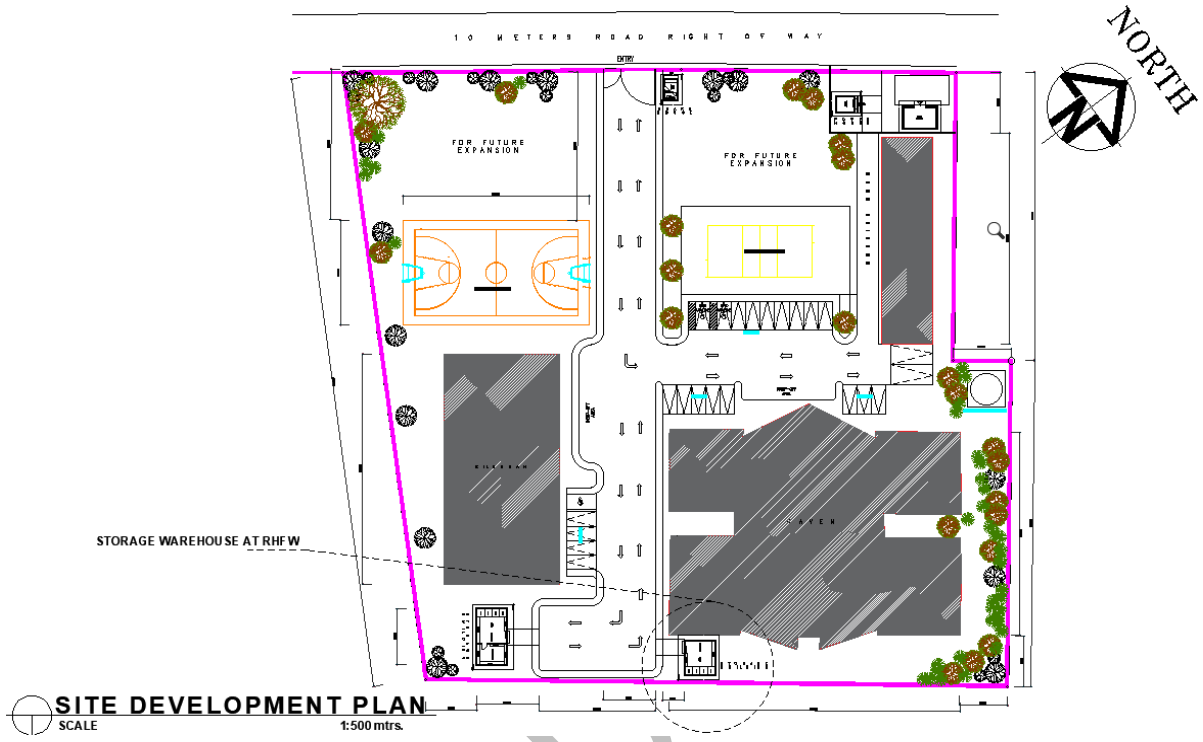

LOT 8: CONSTRUCTION OF ROADWAY AND PARKING AREA (DESIGN & BUILD)

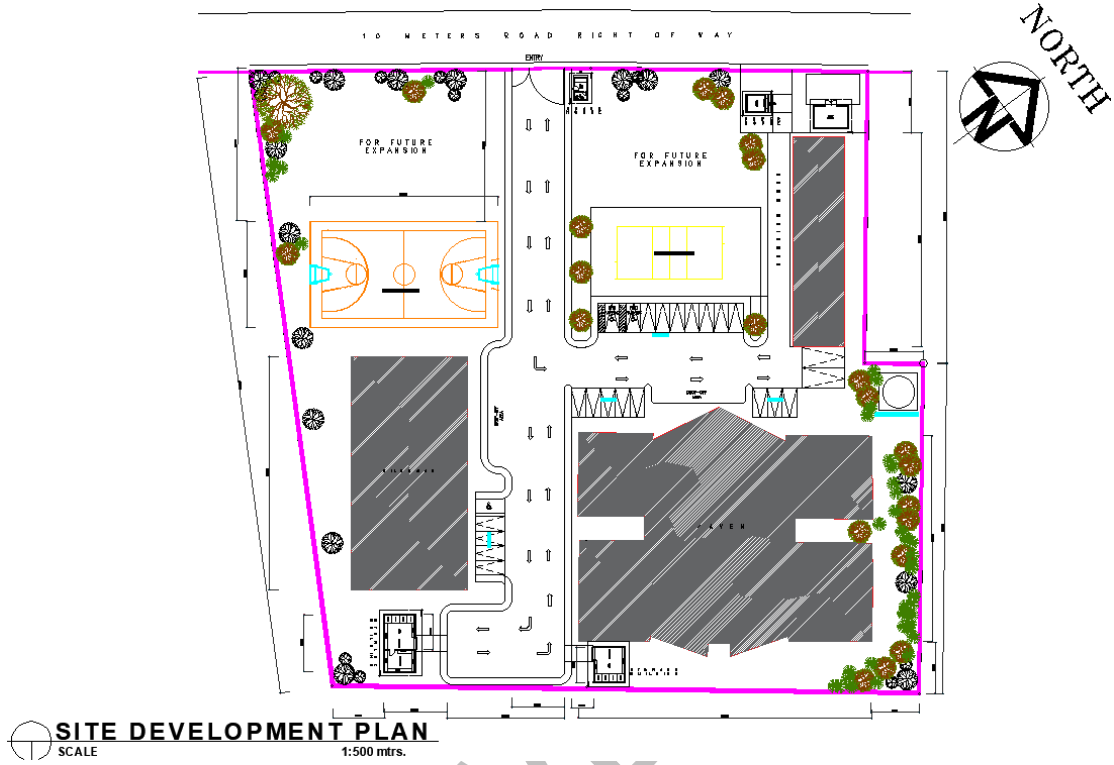

NOMENCLATURE:
 STA - STATION
 PC - POINT OF CURVATURE
 PT - POINT OF TANGENCY

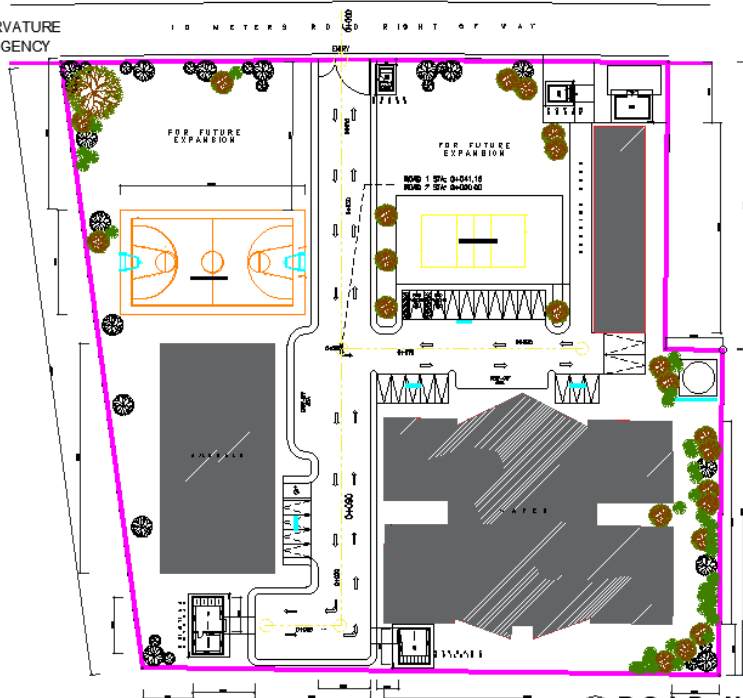

ROAD NETWORK PLAN
 SCALE 1:500 mtrs.

DSWD-F

Section VIII. Bill of Quantities

DSWD-FOX

Section IX. Checklist of Technical and Financial Documents

Notes on the Checklist of Technical and Financial Documents

The prescribed documents in the checklist are mandatory to be submitted in the Bid, but shall be subject to the following:

- a. GPPB Resolution No. 09-2020 on the efficient procurement measures during a State of Calamity or other similar issuances that shall allow the use of alternate documents in lieu of the mandated requirements; or
- b. any subsequent GPPB issuances adjusting the documentary requirements after the effectivity of the adoption of the PBDs.

The BAC shall be checking the submitted documents of each Bidder against this checklist to ascertain if they are all present, using a non-discretionary “pass/fail” criterion pursuant to Section 30 of the 2016 revised IRR of RA No. 9184.

Checklist of Technical and Financial Documents

I. TECHNICAL COMPONENT ENVELOPE

Class "A" Documents

Legal Documents

- (a) Valid PhilGEPS Registration Certificate (Platinum Membership) (all pages) in accordance with Section 8.5.2 of the IRR;

Technical Documents

- (b) Statement of the prospective bidder of all its ongoing government and private contracts, including contracts awarded but not yet started, if any, whether similar or not similar in nature and complexity to the contract to be bid; **and**
- (c) Statement of the bidder's Single Largest Completed Contract (SLCC) similar to the contract to be bid, except under conditions provided under the rules; **and**
- (d) Philippine Contractors Accreditation Board (PCAB) License; **or**
Special PCAB License in case of Joint Ventures **and** registration for the type and cost of the contract to be bid; **and**
- (e) Original copy of Bid Security. If in the form of a Surety Bond, submit also a certification issued by the Insurance Commission **or** Original copy of Notarized Bid Securing Declaration; **and**
- (f) Project Requirements, which shall include the following:
 - a. Organizational chart for the contract to be bid;
 - b. List of contractor's key personnel (*e.g.*, Project Manager, Project Engineers, Materials Engineers, and Foremen), to be assigned to the contract to be bid, with their complete qualification and experience data;
 - c. Construction Schedule and S-Curve;
 - d. Manpower Schedule;
 - e. Construction Methods;
 - f. Equipment Utilization Schedule;
 - g. Construction Safety and Health Program approved by the Department of Labor and Employment – to be submitted 5 calendar days after receipt of NOA;
 - h. PERT/CPM;
 - i. Contractor's All Risk Insurance – to be submitted 5 working days after receipt of NOA
 - j. List of contractor's major equipment units, which are owned, leased, and/or under purchase agreements, supported by proof of ownership or certification of availability of equipment from the equipment lessor/vendor for the duration of the project, as the case may be; **and**

- (g) Original duly signed Omnibus Sworn Statement (OSS) **and** if applicable, Original Notarized Secretary's Certificate in case of a corporation, partnership, or cooperative; or Original Special Power of Attorney of all members of the joint venture giving full power and authority to its officer to sign the OSS and do acts to represent the Bidder.

Financial Documents

- (h) The prospective bidder's audited financial statements, showing, among others, the prospective bidder's total and current assets and liabilities, stamped "received" by the BIR or its duly accredited and authorized institutions, for the preceding calendar year which should not be earlier than two (2) years from the date of bid submission; **and**
- (i) The prospective bidder's computation of Net Financial Contracting Capacity (NFCC).

Class "B" Documents

- (j) If applicable, duly signed joint venture agreement (JVA) in accordance with RA No. 4566 and its IRR in case the joint venture is already in existence **or**

duly notarized statements from all the potential joint venture partners stating that they will enter into and abide by the provisions of the JVA in the instance that the bid is successful.

II. FINANCIAL COMPONENT ENVELOPE

- (k) Original of duly signed and accomplished Financial Bid Form; **and**

Other documentary requirements under RA No. 9184

- (l) Original of duly signed Bid Prices in the Bill of Quantities; **and**
- (m) Duly accomplished Detailed Estimates Form, including a summary sheet indicating the unit prices of construction materials, labor rates, and equipment rentals used in coming up with the Bid; **and**
- (n) Cash Flow by Quarter; **and**
- (o) Certificate of Site Visit

Section X. Bidding Forms

DSWD-FOX

Bid Form for the Procurement of Infrastructure Projects
[shall be submitted with the Bid]

BID FORM

Date: _____
Project Identification No. : _____

To: *[name and address of Procuring Entity]*

Having examined the Philippine Bidding Documents (PBDs) including the Supplemental or Bid Bulletin Numbers *[insert numbers]*, the receipt of which is hereby duly acknowledged, we, the undersigned, declare that:

- a. We have no reservation to the PBDs, including the Supplemental or Bid Bulletins, for the Procurement Project: *[insert name of contract]*;
- b. We offer to execute the Works for this Contract in accordance with the PBDs;
- c. The total price of our Bid in words and figures, excluding any discounts offered below is: *[insert information]*;
- d. The discounts offered and the methodology for their application are: *[insert information]*;
- e. The total bid price includes the cost of all taxes, such as, but not limited to: *[specify the applicable taxes, e.g. (i) value added tax (VAT), (ii) income tax, (iii) local taxes, and (iv) other fiscal levies and duties]*, which are itemized herein and reflected in the detailed estimates,
- f. Our Bid shall be valid within the a period stated in the PBDs, and it shall remain binding upon us at any time before the expiration of that period;
- g. If our Bid is accepted, we commit to obtain a Performance Security in the amount of *[insert percentage amount]* percent of the Contract Price for the due performance of the Contract, or a Performance Securing Declaration in lieu of the the allowable forms of Performance Security, subject to the terms and conditions of issued GPPB guidelines¹ for this purpose;
- h. We are not participating, as Bidders, in more than one Bid in this bidding process, other than alternative offers in accordance with the Bidding Documents;
- i. We understand that this Bid, together with your written acceptance thereof included in your notification of award, shall constitute a binding contract between us, until a formal Contract is prepared and executed; and
- j. We understand that you are not bound to accept the Lowest Calculated Bid or any other Bid that you may receive.

¹ currently based on GPPB Resolution No. 09-2020

- k. We likewise certify/confirm that the undersigned, is the duly authorized representative of the bidder, and granted full power and authority to do, execute and perform any and all acts necessary to participate, submit the bid, and to sign and execute the ensuing contract for the [Name of Project] of the [Name of the Procuring Entity].

- l. We acknowledge that failure to sign each and every page of this Bid Form, including the Bill of Quantities, shall be a ground for the rejection of our bid.

Name: _____

Legal Capacity: _____

Signature: _____

Duly authorized to sign the Bid for and behalf of: _____

Date: _____

DSWD-FOX

Statement of All On-Going Government and Private Contracts, Including Contracts Awarded but Not Yet Started, Whether Similar or Not Similar in Nature and Complexity to the Contract to be Bid

Business Name: _____

Business Address: _____

A. Government

Nature of Contract (Project Title)	a. Owner's Name	Project Cost	Bidder's Role		a. Date Awarded	% of Accomplishment		Value of Outstanding Works (Undelivered Portion)
	b. Address		Description	%	b. Date Started	Planned	Actual	
	c. Contact Nos.				c. Target Date of Completion			
1	a.				a.			
	b.				b.			
	c.				c.			
2	a.				a.			
	b.				b.			
	c.				c.			

B. Private

Nature of Contract (Project Title)	a. Owner's Name	Project Cost	Bidder's Role		a. Date Awarded	% of Accomplishment		Value of Outstanding Works (Undelivered Portion)
	b. Address		Description	%	b. Date Started	Planned	Actual	
	c. Contact Nos.				c. Target Date of Completion			
1	a.				a.			
	b.				b.			
	c.				c.			
2	a.				a.			
	b.				b.			
	c.				c.			

*Note: The following documents must be available upon request of the Bids and Award Committee (BAC) or designated Technical Working Group (TWG) during Post-Qualification to support this statement: (a) **Contract or Purchase Order**, (b) **Official Receipt(s) or Sales Invoice** or (c) **User's Certificate of Acceptance/Completion***

Name: _____

Legal Capacity: _____

Signature: _____

Duly authorized to sign the Bid for and behalf of: _____

Date: _____

Statement of Single Largest Completed Contract (SLCC) ² Similar to the Contract to be Bid

Business Name: _____

Business Address: _____

Nature of Contract (Project Title)	a. Owner's Name	Project Cost	Bidder's Role		a. Date Awarded
	b. Address		Description	%	b. Date Started
	c. Contact Nos.				c. Date Completed
	a.				a.
	b.				b.
	c.				c.

Note: *The following documents must be attached to support this statement: (a) Official Receipt(s) or Sales Invoice or (b) User's Certificate of Acceptance/Completion*

Name: _____

Legal Capacity: _____

Signature: _____

Duly authorized to sign the Bid for and behalf of: _____

Date: _____

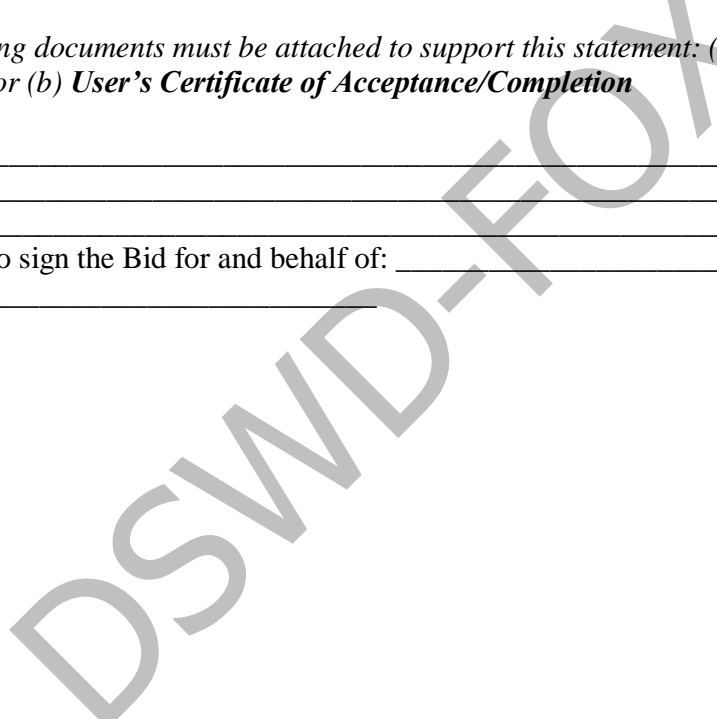

² The Bidder must have completed, within the period specified in the Invitation to Bid and ITB Clause 5.3 of Section III. Bid Data Sheet, a single contract that is similar to the project to be bid, equivalent to a percentage (%) of the ABC specified in ITB Clause 5.3(a) of Section II. Instruction to Bidders.

Bid Securing Declaration Form

[shall be submitted with the Bid if bidder opts to provide this form of bid security]

REPUBLIC OF THE PHILIPPINES)
CITY OF _____) S.S.

BID SECURING DECLARATION **Project Identification No.: *[Insert number]***

To: *[Insert name and address of the Procuring Entity]*

I/We, the undersigned, declare that:

1. I/We understand that, according to your conditions, bids must be supported by a Bid Security, which may be in the form of a Bid Securing Declaration.
2. I/We accept that: (a) I/we will be automatically disqualified from bidding for any procurement contract with any procuring entity for a period of two (2) years upon receipt of your Blacklisting Order; and, (b) I/we will pay the applicable fine provided under Section 6 of the Guidelines on the Use of Bid Securing Declaration, within fifteen (15) days from receipt of the written demand by the procuring entity for the commission of acts resulting to the enforcement of the bid securing declaration under Sections 23.1(b), 34.2, 40.1 and 69.1, except 69.1(f), of the IRR of RA No. 9184; without prejudice to other legal action the government may undertake.
3. I/We understand that this Bid Securing Declaration shall cease to be valid on the following circumstances:
 - a. Upon expiration of the bid validity period, or any extension thereof pursuant to your request;
 - b. I am/we are declared ineligible or post-disqualified upon receipt of your notice to such effect, and (i) I/we failed to timely file a request for reconsideration or (ii) I/we filed a waiver to avail of said right; and
 - c. I am/we are declared the bidder with the Lowest Calculated Responsive Bid, and I/we have furnished the performance security and signed the Contract.

IN WITNESS WHEREOF, I/We have hereunto set my/our hand/s this ____ day of *[month]* *[year]* at *[place of execution]*.

[Insert NAME OF BIDDER OR ITS AUTHORIZED REPRESENTATIVE]

[Insert signatory's legal capacity]

Affiant

[Jurat]

[Format shall be based on the latest Rules on Notarial Practice]

Omnibus Sworn Statement (Revised)

[shall be submitted with the Bid]

REPUBLIC OF THE PHILIPPINES)
CITY/MUNICIPALITY OF _____) S.S.

AFFIDAVIT

I, [Name of Affiant], of legal age, [Civil Status], [Nationality], and residing at [Address of Affiant], after having been duly sworn in accordance with law, do hereby depose and state that:

1. *[Select one, delete the other:]*

[If a sole proprietorship:] I am the sole proprietor or authorized representative of [Name of Bidder] with office address at [address of Bidder];

[If a partnership, corporation, cooperative, or joint venture:] I am the duly authorized and designated representative of [Name of Bidder] with office address at [address of Bidder];

2. *[Select one, delete the other:]*

[If a sole proprietorship:] As the owner and sole proprietor, or authorized representative of [Name of Bidder], I have full power and authority to do, execute and perform any and all acts necessary to participate, submit the bid, and to sign and execute the ensuing contract for [Name of the Project] of the [Name of the Procuring Entity], as shown in the attached duly notarized Special Power of Attorney;

[If a partnership, corporation, cooperative, or joint venture:] I am granted full power and authority to do, execute and perform any and all acts necessary to participate, submit the bid, and to sign and execute the ensuing contract for [Name of the Project] of the [Name of the Procuring Entity], as shown in the attached [state title of attached document showing proof of authorization (e.g., duly notarized Secretary's Certificate, Board/Partnership Resolution, or Special Power of Attorney, whichever is applicable);];

3. [Name of Bidder] is not "blacklisted" or barred from bidding by the Government of the Philippines or any of its agencies, offices, corporations, or Local Government Units, foreign government/foreign or international financing institution whose blacklisting rules have been recognized by the Government Procurement Policy Board, **by itself or by relation, membership, association, affiliation, or controlling interest with another blacklisted person or entity as defined and provided for in the Uniform Guidelines on Blacklisting;**

4. Each of the documents submitted in satisfaction of the bidding requirements is an authentic copy of the original, complete, and all statements and information provided therein are true and correct;

5. [Name of Bidder] is authorizing the Head of the Procuring Entity or its duly authorized representative(s) to verify all the documents submitted;

6. *[Select one, delete the rest:]*

[If a sole proprietorship:] The owner or sole proprietor is not related to the Head of the Procuring Entity, Procurement Agent if engaged, members of the Bids and Awards

Committee (BAC), the Technical Working Group, and the BAC Secretariat, the head of the Project Management Office or the end-user unit, and the project consultants by consanguinity or affinity up to the third civil degree;

[If a partnership or cooperative:] None of the officers and members of *[Name of Bidder]* is related to the Head of the Procuring Entity, Procurement Agent if engaged, members of the Bids and Awards Committee (BAC), the Technical Working Group, and the BAC Secretariat, the head of the Project Management Office or the end-user unit, and the project consultants by consanguinity or affinity up to the third civil degree;

[If a corporation or joint venture:] None of the officers, directors, and controlling stockholders of *[Name of Bidder]* is related to the Head of the Procuring Entity, Procurement Agent if engaged, members of the Bids and Awards Committee (BAC), the Technical Working Group, and the BAC Secretariat, the head of the Project Management Office or the end-user unit, and the project consultants by consanguinity or affinity up to the third civil degree;

7. *[Name of Bidder]* complies with existing labor laws and standards; and
8. *[Name of Bidder]* is aware of and has undertaken the responsibilities as a Bidder in compliance with the Philippine Bidding Documents, which includes:
 - a. Carefully examining all of the Bidding Documents;
 - b. Acknowledging all conditions, local or otherwise, affecting the implementation of the Contract;
 - c. Making an estimate of the facilities available and needed for the contract to be bid, if any; and
 - d. Inquiring or securing Supplemental/Bid Bulletin(s) issued for the *[Name of the Project]*.
9. *[Name of Bidder]* did not give or pay directly or indirectly, any commission, amount, fee, or any form of consideration, pecuniary or otherwise, to any person or official, personnel or representative of the government in relation to any procurement project or activity.
10. **In case advance payment was made or given, failure to perform or deliver any of the obligations and undertakings in the contract shall be sufficient grounds to constitute criminal liability for Swindling (Estafa) or the commission of fraud with unfaithfulness or abuse of confidence through misappropriating or converting any payment received by a person or entity under an obligation involving the duty to deliver certain goods or services, to the prejudice of the public and the government of the Philippines pursuant to Article 315 of Act No. 3815 s. 1930, as amended, or the Revised Penal Code.**

IN WITNESS WHEREOF, I have hereunto set my hand this __ day of __, 20__ at _____, Philippines.

[Insert NAME OF BIDDER OR ITS AUTHORIZED REPRESENTATIVE]

[Insert signatory's legal capacity]

Affiant

[Jurat]

[Format shall be based on the latest Rules on Notarial Practice]