

PHILIPPINE BIDDING DOCUMENTS

**Remodeling of a
Portion of DRMD
Warehouse to RRROS
and DRCC Offices
ITB NO. 2024-03-08**

Department of Social Welfare and
Development Field Office X
Government of the Republic of the Philippines

**Sixth Edition
March 31, 2024**

TABLE OF CONTENTS

<u>Glossary of Terms, Abbreviations, and Acronyms</u>	4
<u>Section I. Invitation to Bid</u>	7
<u>Section II. Instructions to Bidders</u>	11
<u>1. Scope of Bid</u>	12
<u>2. Funding Information</u>	12
<u>3. Bidding Requirements</u>	12
<u>4. Corrupt, Fraudulent, Collusive, Coercive, and Obstructive Practices</u>	12
<u>5. Eligible Bidders</u>	12
<u>6. Origin of Associated Goods</u>	13
<u>7. Subcontracts</u>	13
<u>8. Pre-Bid Conference</u>	13
<u>9. Clarification and Amendment of Bidding Documents</u>	13
<u>10. Documents Comprising the Bid: Eligibility and Technical Components</u>	13
<u>11. Documents Comprising the Bid: Financial Component</u>	14
<u>12. Alternative Bids</u>	14
<u>13. Bid Prices</u>	14
<u>14. Bid and Payment Currencies</u>	14
<u>15. Bid Security</u>	14
<u>16. Sealing and Marking of Bids</u>	15
<u>17. Deadline for Submission of Bids</u>	15
<u>18. Opening and Preliminary Examination of Bids</u>	15
<u>19. Detailed Evaluation and Comparison of Bids</u>	15
<u>20. Post Qualification</u>	16
<u>21. Signing of the Contract</u>	16
<u>Section III. Bid Data Sheet</u>	17
<u>Section IV. General Conditions of Contract</u>	20
<u>1. Scope of Contract</u>	21
<u>2. Sectional Completion of Works</u>	21
<u>3. Possession of Site</u>	21
<u>4. The Contractor's Obligations</u>	21
<u>5. Performance Security</u>	21
<u>6. Site Investigation Reports</u>	22
<u>7. Warranty</u>	22

<u>8.</u>	<u>Liability of the Contractor</u>	22
<u>9.</u>	<u>Termination for Other Causes</u>	22
<u>10.</u>	<u>Dayworks</u>	22
<u>11.</u>	<u>Program of Work</u>	23
<u>12.</u>	<u>Instructions, Inspections and Audits</u>	23
<u>13.</u>	<u>Advance Payment</u>	23
<u>14.</u>	<u>Progress Payments</u>	23
<u>15.</u>	<u>Operating and Maintenance Manuals</u>	23
	<u>Section V. Special Conditions of Contract</u>	24
	<u>Section VI. Specifications</u>	27
	<u>Section VII. Drawings</u>	28
	<u>Section VIII. Bill of Quantities</u>	96
	<u>Section IX. Checklist of Technical and Financial Documents</u>	100
	<u>Section X. Bidding Forms</u>	103

Glossary of Terms, Abbreviations, and Acronyms

ABC – Approved Budget for the Contract.

ARCC – Allowable Range of Contract Cost.

BAC – Bids and Awards Committee.

Bid – A signed offer or proposal to undertake a contract submitted by a bidder in response to and in consonance with the requirements of the bidding documents. Also referred to as *Proposal* and *Tender*. (2016 revised IRR, Section 5[c])

Bidder – Refers to a contractor, manufacturer, supplier, distributor and/or consultant who submits a bid in response to the requirements of the Bidding Documents. (2016 revised IRR, Section 5[d])

Bidding Documents – The documents issued by the Procuring Entity as the bases for bids, furnishing all information necessary for a prospective bidder to prepare a bid for the Goods, Infrastructure Projects, and/or Consulting Services required by the Procuring Entity. (2016 revised IRR, Section 5[e])

BIR – Bureau of Internal Revenue.

BSP – Bangko Sentral ng Pilipinas.

CDA – Cooperative Development Authority.

Consulting Services – Refer to services for Infrastructure Projects and other types of projects or activities of the GOP requiring adequate external technical and professional expertise that are beyond the capability and/or capacity of the GOP to undertake such as, but not limited to: (i) advisory and review services; (ii) pre-investment or feasibility studies; (iii) design; (iv) construction supervision; (v) management and related services; and (vi) other technical services or special studies. (2016 revised IRR, Section 5[i])

Contract – Refers to the agreement entered into between the Procuring Entity and the Supplier or Manufacturer or Distributor or Service Provider for procurement of Goods and Services; Contractor for Procurement of Infrastructure Projects; or Consultant or Consulting Firm for Procurement of Consulting Services; as the case may be, as recorded in the Contract Form signed by the parties, including all attachments and appendices thereto and all documents incorporated by reference therein.

Contractor – is a natural or juridical entity whose proposal was accepted by the Procuring Entity and to whom the Contract to execute the Work was awarded. Contractor as used in these Bidding Documents may likewise refer to a supplier, distributor, manufacturer, or consultant.

CPI – Consumer Price Index.

DOLE – Department of Labor and Employment.

DTI – Department of Trade and Industry.

Foreign-funded Procurement or Foreign-Assisted Project – Refers to procurement whose funding source is from a foreign government, foreign or international financing institution as specified in the Treaty or International or Executive Agreement. (2016 revised IRR, Section 5[b]).

GFI – Government Financial Institution.

GOCC – Government-owned and/or –controlled corporation.

Goods – Refer to all items, supplies, materials and general support services, except Consulting Services and Infrastructure Projects, which may be needed in the transaction of public businesses or in the pursuit of any government undertaking, project or activity, whether in the nature of equipment, furniture, stationery, materials for construction, or personal property of any kind, including non-personal or contractual services such as the repair and maintenance of equipment and furniture, as well as trucking, hauling, janitorial, security, and related or analogous services, as well as procurement of materials and supplies provided by the Procuring Entity for such services. The term “related” or “analogous services” shall include, but is not limited to, lease or purchase of office space, media advertisements, health maintenance services, and other services essential to the operation of the Procuring Entity. (2016 revised IRR, Section 5[r])

GOP – Government of the Philippines.

Infrastructure Projects – Include the construction, improvement, rehabilitation, demolition, repair, restoration or maintenance of roads and bridges, railways, airports, seaports, communication facilities, civil works components of information technology projects, irrigation, flood control and drainage, water supply, sanitation, sewerage and solid waste management systems, shore protection, energy/power and electrification facilities, national buildings, school buildings, hospital buildings, and other related construction projects of the government. Also referred to as *civil works or works*. (2016 revised IRR, Section 5[u])

LGUs – Local Government Units.

NFCC – Net Financial Contracting Capacity.

NGA – National Government Agency.

PCAB – Philippine Contractors Accreditation Board.

PhilGEPS - Philippine Government Electronic Procurement System.

Procurement Project – refers to a specific or identified procurement covering goods, infrastructure project or consulting services. A Procurement Project shall be described, detailed, and scheduled in the Project Procurement Management Plan prepared by the agency which shall be consolidated in the procuring entity's Annual Procurement Plan. (GPPB Circular No. 06-2019 dated 17 July 2019)

PSA – Philippine Statistics Authority.

SEC – Securities and Exchange Commission.

SLCC – Single Largest Completed Contract.

UN – United Nations.

Section I. Invitation to Bid

Invitation to Bid for the Remodeling of a Portion of DRMD Warehouse to RROS and DRCC Offices

1. The Department of Social Welfare and Development Field Office X through the General Appropriations Act FY 2024 intends to apply the sum of **One Million Two Hundred Fifty-Eight Thousand One Hundred Four Pesos and 50/100 (Php 1,258,104.50)** being the Approved Budget for the Contract (ABC) to payments under the contract for the Remodeling of a Portion of DRMD Warehouse to RROS and DRCC Offices under ITB NO.2024-03-08. Bids received in excess of the ABC shall be automatically rejected at bid opening.
2. The Department of Social Welfare and Development Field Office X now invites bids for the above Procurement Project. Completion of the Works is required should be based on what is stipulated in the Schedule of Requirements. Prospective Bidders must have completed a similar contract within the preceding two (2) years, a single contract equivalent to at least fifty (50%) percent of the Approved Budget Cost. The description of an eligible bidder is contained in the Bidding Documents, particularly, in Section II. Instructions to Bidders.
3. Bidding will be conducted through open competitive bidding procedures using non-discretionary “pass/fail” criterion as specified in the 2016 revised Implementing Rules and Regulations (IRR) of Republic Act (RA) No. 9184.
4. Interested bidders may obtain further information from DSWD FO X – BAC Secretariat and inspect the Bidding Documents at the address given below from **8:00 AM - 5:00 PM starting April 1, 2024**.
5. A complete set of Bidding Documents may be acquired by interested bidders on the given address and website/s below and upon payment of the applicable fee for the Bidding Documents, pursuant to the latest Guidelines issued by the GPPB, in the amount of Five Thousand Pesos (₱5,000.00). The Procuring Entity shall allow the bidder to present its proof of payment for the fees in person or through e-mail during the conduct of bid opening.
6. The DSWD FO X will hold Virtual Pre-Bid Conference through videoconferencing via google meet (<https://meet.google.com/psr-mwrs-mgi>) on **April 8, 2024 @ 1:00 PM onwards**, which shall be open to prospective bidders.
7. Bids must be duly received by the BAC Secretariat through manual submission at the office address as indicated below on or before **April 22, 2024 @ 12:00 PM**. Late bids shall not be accepted.
8. All bids must be accompanied by a bid security in any of the acceptable forms and in the amount stated in **ITB Clause 15**.
9. Virtual Bid opening through videoconferencing via Google meet shall be on **April 22, 2024 @ 1:00 PM onwards**. Bids will be opened in the presence of the bidders’ representatives who choose to attend the activity. The links will be provided upon submission of bid documents.
10. Each Bidder shall submit one (1) original and two (2) more duplicate copies of its Bid, which shall be properly sealed and marked, to wit:
 - **ORIGINAL BID (BLUE ENVELOPE)**

Enclose the Original eligibility and technical documents in one sealed envelope marked “ORIGINAL – TECHNICAL COMPONENT” and the Original financial component in another sealed envelope marked “ORIGINAL – FINANCIAL COMPONENT”. Seal both envelopes in an outer envelope marked “ORIGINAL BID”

➤ **COPY 1 (RED ENVELOPE)**

Enclose the certified true copies of eligibility and technical documents in one sealed envelope marked “COPY 1 – TECHNICAL COMPONENT” and the certified true copies of financial component in another sealed envelope marked “COPY 1 – FINANCIAL COMPONENT”. Seal both envelopes in an outer envelope marked “COPY 1”.

➤ **COPY 2 (YELLOW ENVELOPE)**

Enclose the certified true copies of eligibility and technical documents in one sealed envelope marked “COPY 2 – TECHNICAL COMPONENT” and the certified true copies of financial component in another sealed envelope marked “COPY 2 – FINANCIAL COMPONENT”. Seal both envelopes in an outer envelope marked “COPY 2”.

The Original Bid, Copy 1, and Copy 2 Envelopes, shall then be CONTAINED in ONE ENVELOPE (OVERALL BID COMPONENT ENVELOPE) duly marked and sealed.

ALL envelopes shall:

- Contain the ITB No. and the name of the contract to be bid in CAPITAL LETTERS;
- Bear the name and address of the bidder in CAPITAL LETTERS;
- Be addressed to:

THE CHAIRPERSON
BIDS AND AWARDS COMMITTEE

DEPARTMENT OF SOCIAL WELFARE AND DEVELOPMENT FO X

MASTERSON AVE., UPPER CARMEN, CAGAYAN DE ORO CITY

- Bear a warning “DO NOT OPEN BEFORE:” stating the date & time for opening of bids in accordance with the ITB

Prospective Bidder is requested to indicate a label or tab marking on each technical and financial documents required to be submitted.

11. To resolve cases where there is an occurrence of a tie among bidders, i.e., two or more of the bidders have been post-qualified as the Lowest Calculated Responsive Bid (LCRB), the DSWD FO X shall resort to a non-discretionary and non-discriminatory measure such that the same is based on sheer luck or chance as per GPPB Circular No. 06-2005 "Tie-Breaking Method".
12. The DSWD FO X reserves the right to reject any and all bids, declare a failure of bidding, or not award the contract at any time prior to contract award in accordance with Sections 35.6 and 41 of the 2016 revised Implementing Rules and Regulations

(IRR) of RA No. 9184, without thereby incurring any liability to the affected bidder or bidders.

13. For further information, please refer to:

ATTY. JUSTINE PHILLIP O. TADEO

Head, BAC Secretariat

DSWD Field Office X

Masterson Avenue, Upper Carmen, Cagayan de Oro City

Mobile No. +639754860960

bac.fo10@dswd.gov.ph

14. You may visit the following websites for downloading of Bidding Documents:
www.philgeps.gov.ph or **<https://fo10.dswd.gov.ph/>**

March 31, 2024

RONALD RYAN R. CUI

Chairperson, Bids and Awards Committee

Section II. Instructions to Bidders

1. **Scope of Bid**

The Procuring Entity, Department of Social Welfare and Development Field Office X invites Bids for the Remodeling of a Portion of DRMD Warehouse to RROS and DRCC Offices, with Project Identification Number 2024-03-08.

The Procurement Project (referred to herein as “Project”) is for the construction of Works, as described in Section VI (Specifications).

2. **Funding Information**

2.1. The GOP through the source of funding as indicated below for **General Appropriations Act FY 2024** in the amount of **One Million Two Hundred Fifty-Eight Thousand One Hundred Four Pesos and 50/100 (Php 1,258,104.50)**.

2.2. The source of funding is the National Expenditure Program.

3. **Bidding Requirements**

The Bidding for the Project shall be governed by all the provisions of RA No. 9184 and its 2016 revised IRR, including its Generic Procurement Manual and associated policies, rules and regulations as the primary source thereof, while the herein clauses shall serve as the secondary source thereof.

Any amendments made to the IRR and other GPPB issuances shall be applicable only to the ongoing posting, advertisement, or invitation to bid by the BAC through the issuance of a supplemental or bid bulletin.

The Bidder, by the act of submitting its Bid, shall be deemed to have inspected the site, determined the general characteristics of the contracted Works and the conditions for this Project, such as the location and the nature of the work; (b) climatic conditions; (c) transportation facilities; (c) nature and condition of the terrain, geological conditions at the site communication facilities, requirements, location and availability of construction aggregates and other materials, labor, water, electric power and access roads; and (d) other factors that may affect the cost, duration and execution or implementation of the contract, project, or work and examine all instructions, forms, terms, and project requirements in the Bidding Documents.

4. **Corrupt, Fraudulent, Collusive, Coercive, and Obstructive Practices**

The Procuring Entity, as well as the Bidders and Contractors, shall observe the highest standard of ethics during the procurement and execution of the contract. They or through an agent shall not engage in corrupt, fraudulent, collusive, coercive, and obstructive practices defined under Annex “I” of the 2016 revised IRR of RA No. 9184 or other integrity violations in competing for the Project.

5. **Eligible Bidders**

Only Bids of Bidders found to be legally, technically, and financially capable will be evaluated.

The Bidder must have an experience of having completed a Single Largest Completed Contract (SLCC) that is similar to this Project, equivalent to at least fifty percent (50%) of the ABC adjusted, if necessary, by the Bidder to current prices using the PSA’s CPI,

except under conditions provided for in Section 23.4.2.4 of the 2016 revised IRR of RA No. 9184.

A contract is considered to be “similar” to the contract to be bid if it has the major categories of work stated in the **BDS**.

For Foreign-funded Procurement, the Procuring Entity and the foreign government/foreign or international financing institution may agree on another track record requirement, as specified in the Bidding Document prepared for this purpose.

The Bidders shall comply with the eligibility criteria under Section 23.4.2 of the 2016 IRR of RA No. 9184.

6. Origin of Associated Goods

There is no restriction on the origin of Goods other than those prohibited by a decision of the UN Security Council taken under Chapter VII of the Charter of the UN.

7. Subcontracts

The Bidder may subcontract portions of the Project to the extent allowed by the Procuring Entity as stated herein, but in no case more than fifty percent (50%) of the Project.

The Procuring Entity has prescribed that Subcontracting is not allowed.

8. Pre-Bid Conference

The Procuring Entity will hold a pre-bid conference for this Project through videoconferencing via google meet (<https://meet.google.com/psr-mwrs-mgi>) on *April 8, 2024 @ 1:00 PM onwards.*

9. Clarification and Amendment of Bidding Documents

Prospective bidders may request for clarification on and/or interpretation of any part of the Bidding Documents. Such requests must be in writing and received by the Procuring Entity, either at its given address or through electronic mail indicated in the **IB**, at least ten (10) calendar days before the deadline set for the submission and receipt of Bids.

10. Documents Comprising the Bid: Eligibility and Technical Components

10.1. The first envelope shall contain the eligibility and technical documents of the Bid as specified in **Section IX. Checklist of Technical and Financial Documents**.

10.2. If the eligibility requirements or statements, the bids, and all other documents for submission to the BAC are in foreign language other than English, it must be accompanied by a translation in English, which shall be authenticated by the appropriate Philippine foreign service establishment, post, or the equivalent office having jurisdiction over the foreign bidder's affairs in the Philippines. For Contracting Parties to the Apostille Convention, only the translated documents shall be authenticated through an apostille pursuant to GPPB

Resolution No. 13-2019 dated 23 May 2019. The English translation shall govern, for purposes of interpretation of the bid.

- 10.3. A valid special PCAB License in case of Joint Ventures, and registration for the type and cost of the contract for this Project. Any additional type of Contractor license or permit shall be indicated in the **BDS**.
- 10.4. A List of Contractor's key personnel (e.g., Project Manager, Project Engineers, Materials Engineers, and Foremen) assigned to the contract to be bid, with their complete qualification and experience data shall be provided. These key personnel must meet the required minimum years of experience set in the **BDS**.
- 10.5. A List of Contractor's major equipment units, which are owned, leased, and/or under purchase agreements, supported by proof of ownership, certification of availability of equipment from the equipment lessor/vendor for the duration of the project, as the case may be, must meet the minimum requirements for the contract set in the **BDS**.

11. Documents Comprising the Bid: Financial Component

- 11.1. The second bid envelope shall contain the financial documents for the Bid as specified in **Section IX. Checklist of Technical and Financial Documents**.
- 11.2. Any bid exceeding the ABC indicated in paragraph 1 of the **IB** shall not be accepted.
- 11.3. For Foreign-funded procurement, a ceiling may be applied to bid prices provided the conditions are met under Section 31.2 of the 2016 revised IRR of RA No. 9184.

12. Alternative Bids

Bidders shall submit offers that comply with the requirements of the Bidding Documents, including the basic technical design as indicated in the drawings and specifications. Unless there is a value engineering clause in the **BDS**, alternative Bids shall not be accepted.

13. Bid Prices

All bid prices for the given scope of work in the Project as awarded shall be considered as fixed prices, and therefore not subject to price escalation during contract implementation, except under extraordinary circumstances as determined by the NEDA and approved by the GPPB pursuant to the revised Guidelines for Contract Price Escalation guidelines.

14. Bid and Payment Currencies

- 14.1. Bid prices may be quoted in the local currency or tradeable currency accepted by the BSP at the discretion of the Bidder. However, for purposes of bid evaluation, Bids denominated in foreign currencies shall be converted to Philippine currency based on the exchange rate as published in the BSP reference rate bulletin on the day of the bid opening.
- 14.2. Payment of the contract price shall be made in Philippine Pesos.

15. Bid Security

- 15.1. The Bidder shall submit a Bid Securing Declaration or any form of Bid Security in the amount indicated in the **BDS**, which shall be not less than the percentage of the ABC in accordance with the schedule in the **BDS**.
- 15.2. The Bid and bid security shall be valid until August 20, 2024. Any bid not accompanied by an acceptable bid security shall be rejected by the Procuring Entity as non-responsive.

16. Sealing and Marking of Bids

Each Bidder shall submit one copy of the first and second components of its Bid.

The Procuring Entity may request additional hard copies and/or electronic copies of the Bid. However, failure of the Bidders to comply with the said request shall not be a ground for disqualification.

If the Procuring Entity allows the submission of bids through online submission to the given website or any other electronic means, the Bidder shall submit an electronic copy of its Bid, which must be digitally signed. An electronic copy that cannot be opened or is corrupted shall be considered non-responsive and, thus, automatically disqualified.

17. Deadline for Submission of Bids

The Bidders shall submit on the specified date and time and either at its physical address or through online submission as indicated in paragraph 7 of the **IB**.

18. Opening and Preliminary Examination of Bids

- 18.1. The BAC shall open the Bids in public at the time, on the date, and at the place specified in paragraph 9 of the **IB**. The Bidders' representatives who are present shall sign a register evidencing their attendance. In case videoconferencing, webcasting or other similar technologies will be used, attendance of participants shall likewise be recorded by the BAC Secretariat.

In case the Bids cannot be opened as scheduled due to justifiable reasons, the rescheduling requirements under Section 29 of the 2016 revised IRR of RA No. 9184 shall prevail.

- 18.2. The preliminary examination of Bids shall be governed by Section 30 of the 2016 revised IRR of RA No. 9184.

19. Detailed Evaluation and Comparison of Bids

- 19.1. The Procuring Entity's BAC shall immediately conduct a detailed evaluation of all Bids rated "*passed*" using non-discretionary pass/fail criteria. The BAC shall consider the conditions in the evaluation of Bids under Section 32.2 of 2016 revised IRR of RA No. 9184.
- 19.2. If the Project allows partial bids, all Bids and combinations of Bids as indicated in the **BDS** shall be received by the same deadline and opened and evaluated simultaneously so as to determine the Bid or combination of Bids offering the lowest calculated cost to the Procuring Entity. Bid Security as required by **ITB** Clause 15 shall be submitted for each contract (lot) separately.

19.3. In all cases, the NFCC computation pursuant to Section 23.4.2.6 of the 2016 revised IRR of RA No. 9184 must be sufficient for the total of the ABCs for all the lots participated in by the prospective Bidder.

20. Post Qualification

Within a non-extendible period of five (5) calendar days from receipt by the Bidder of the notice from the BAC that it submitted the Lowest Calculated Bid, the Bidder shall submit its latest income and business tax returns filed and paid through the BIR Electronic Filing and Payment System (eFPS), and other appropriate licenses and permits required by law and stated in the **BDS**.

21. Signing of the Contract

The documents required in Section 37.2 of the 2016 revised IRR of RA No. 9184 shall form part of the Contract. Additional Contract documents are indicated in the **BDS**.

Section III. Bid Data Sheet

Bid Data Sheet

ITB Clause																			
5.2	<p>For this purpose, contracts similar to the Project refer to contracts which have the same major categories of work, which shall be:</p> <p>The Bidder must have completed, within the period specified in the Invitation to Bid, a single contract that is similar to this Project, equivalent to at least fifty percent (50%) of the ABC.</p>																		
7.1	No portion of the contract shall be subcontracted.																		
10.3	<p>a) Valid License Issued by Philippine Contractors Accreditation Board (PCAB) GB-1 Category D and Above</p> <p>b) Department of Trade and Industry (DTI) Certificate of Business Name Registration for Sole Proprietorship, SEC Registration Certificate for Corporations, CDA Registration Certificate for Cooperatives</p> <p>c) Valid and current Business/Mayor's Permit/ Municipal License from the bidder's principal place of Business</p> <p>d) Notarized statement that none of the officers / directors / controlling stockholders / members /owners of the firm are related by consanguinity or affinity up to the 1st civil degree to the employees of DSWD FO-X who <i>have</i> direct access to information that may substantially affect the result of the bidding, such as, but not limited to, the members of the Bids and Awards Committee (BAC), the members of the Technical Working Group (TWG), the Procurement Team (PT), and the designer/s of the Project.</p>																		
10.4	<p>The key personnel must meet the required minimum years of experience set below:</p> <ul style="list-style-type: none"> • One (1) Licensed Project/Civil Engineer with 3 years minimum experience • One (1) Licensed Architect with 3 years minimum experience • One (1) Master Electrician with 5 years minimum experience • One (1) General Foreman with 5 years minimum experience in construction industry 																		
10.5	<p>The minimum major equipment requirements are the following:</p> <table style="width: 100%; border-collapse: collapse;"> <thead> <tr> <th style="text-align: left;"><u>Equipment</u></th> <th style="text-align: left;"><u>Capacity</u></th> <th style="text-align: left;"><u>Number of Units</u></th> </tr> </thead> <tbody> <tr> <td>Hammer Chipping Gun</td> <td>>900W</td> <td>1 Unit</td> </tr> <tr> <td>Bagger Mixer</td> <td></td> <td>1 Unit</td> </tr> <tr> <td>Excavator</td> <td>>0.3cu.m.</td> <td>1 Unit</td> </tr> <tr> <td>Transit Mixer</td> <td>>5cu.m.</td> <td>1 Unit</td> </tr> <tr> <td>Dump Truck</td> <td>>2.5cu.m.</td> <td>1 Unit</td> </tr> </tbody> </table>	<u>Equipment</u>	<u>Capacity</u>	<u>Number of Units</u>	Hammer Chipping Gun	>900W	1 Unit	Bagger Mixer		1 Unit	Excavator	>0.3cu.m.	1 Unit	Transit Mixer	>5cu.m.	1 Unit	Dump Truck	>2.5cu.m.	1 Unit
<u>Equipment</u>	<u>Capacity</u>	<u>Number of Units</u>																	
Hammer Chipping Gun	>900W	1 Unit																	
Bagger Mixer		1 Unit																	
Excavator	>0.3cu.m.	1 Unit																	
Transit Mixer	>5cu.m.	1 Unit																	
Dump Truck	>2.5cu.m.	1 Unit																	
12	No Further Instruction																		
15.1	<p>The bid security shall be in the form of a Bid Securing Declaration or any of the following forms and amounts:</p> <p>a. The amount of not less than Twenty-Five Thousand One Hundred Sixty-Two Pesos and 09/100 (₱25,162.09), if bid security is in cash, cashier's/manager's check, bank draft/guarantee or irrevocable letter of credit;</p>																		

	b. The amount of not less Sixty-Two Thousand Nine Hundred Five Pesos and 23/100 (P62,905.23) if bid security is in Surety Bond.
19.2	Partial bid is not allowed. The Goods are grouped in a single lot and the lot shall not be divided into sub-lots for the purpose of bidding, evaluation, and contract award.
20	Failure to submit the Latest Income and Business Tax Returns shall result to disqualification and forfeiture of bid security.
21	List of additional contract documents relevant to the Project as required by existing laws and/or the Procuring Entity: <ul style="list-style-type: none"> i. Construction schedule and S-curve ii. Manpower Schedule iii. Construction Methods iv. Equipment Utilization Schedule v. Construction Safety and Health Program approved by the Department of Labor and Employment vi. PERT/CPM, and vii. Contractor's All Risk Insurance.

Section IV. General Conditions of Contract

1. Scope of Contract

This Contract shall include all such items, although not specifically mentioned, that can be reasonably inferred as being required for its completion as if such items were expressly mentioned herein. All the provisions of RA No. 9184 and its 2016 revised IRR, including the Generic Procurement Manual, and associated issuances, constitute the primary source for the terms and conditions of the Contract, and thus, applicable in contract implementation. Herein clauses shall serve as the secondary source for the terms and conditions of the Contract.

This is without prejudice to Sections 74.1 and 74.2 of the 2016 revised IRR of RA No. 9184 allowing the GPPB to amend the IRR, which shall be applied to all procurement activities, the advertisement, posting, or invitation of which were issued after the effectivity of the said amendment.

2. Sectional Completion of Works

If sectional completion is specified in the **Special Conditions of Contract (SCC)**, references in the Conditions of Contract to the Works, the Completion Date, and the Intended Completion Date shall apply to any Section of the Works (other than references to the Completion Date and Intended Completion Date for the whole of the Works).

3. Possession of Site

- 3.1 The Procuring Entity shall give possession of all or parts of the Site to the Contractor based on the schedule of delivery indicated in the **SCC**, which corresponds to the execution of the Works. If the Contractor suffers delay or incurs cost from failure on the part of the Procuring Entity to give possession in accordance with the terms of this clause, the Procuring Entity's Representative shall give the Contractor a Contract Time Extension and certify such sum as fair to cover the cost incurred, which sum shall be paid by Procuring Entity.
- 3.2 If possession of a portion is not given by the above date, the Procuring Entity will be deemed to have delayed the start of the relevant activities. The resulting adjustments in contract time to address such delay may be addressed through contract extension provided under Annex "E" of the 2016 revised IRR of RA No. 9184.

4. The Contractor's Obligations

The Contractor shall employ the key personnel named in the Schedule of Key Personnel indicating their designation, in accordance with **ITB** Clause 10.3 and specified in the **BDS**, to carry out the supervision of the Works.

The Procuring Entity will approve any proposed replacement of key personnel only if their relevant qualifications and abilities are equal to or better than those of the personnel listed in the Schedule.

5. Performance Security

- 5.1. Within ten (10) calendar days from receipt of the Notice of Award from the Procuring Entity but in no case later than the signing of the contract by both parties, the successful Bidder shall furnish the performance security in any of the forms prescribed in Section 39 of the 2016 revised IRR.
- 5.2. The Contractor, by entering into the Contract with the Procuring Entity, acknowledges the right of the Procuring Entity to institute action pursuant to RA No. 3688 against any subcontractor be they an individual, firm, partnership, corporation, or association supplying the Contractor with labor, materials and/or equipment for the performance of this Contract.

6. Site Investigation Reports

The Contractor, in preparing the Bid, shall rely on any Site Investigation Reports referred to in the **SCC** supplemented by any information obtained by the Contractor.

7. Warranty

- 7.1. In case the Contractor fails to undertake the repair works under Section 62.2.2 of the 2016 revised IRR, the Procuring Entity shall forfeit its performance security, subject its property(ies) to attachment or garnishment proceedings, and perpetually disqualify it from participating in any public bidding. All payables of the GOP in his favor shall be offset to recover the costs.
- 7.2. The warranty against Structural Defects/Failures, except that occasioned-on force majeure, shall cover the period from the date of issuance of the Certificate of Final Acceptance by the Procuring Entity. Specific duration of the warranty is found in the **SCC**.

8. Liability of the Contractor

Subject to additional provisions, if any, set forth in the **SCC**, the Contractor's liability under this Contract shall be as provided by the laws of the Republic of the Philippines.

If the Contractor is a joint venture, all partners to the joint venture shall be jointly and severally liable to the Procuring Entity.

9. Termination for Other Causes

Contract termination shall be initiated in case it is determined *prima facie* by the Procuring Entity that the Contractor has engaged, before, or during the implementation of the contract, in unlawful deeds and behaviors relative to contract acquisition and implementation, such as, but not limited to corrupt, fraudulent, collusive, coercive, and obstructive practices as stated in **ITB** Clause 4.

10. Dayworks

Subject to the guidelines on Variation Order in Annex "E" of the 2016 revised IRR of RA No. 9184, and if applicable as indicated in the **SCC**, the Dayworks rates in the Contractor's Bid shall be used for small additional amounts of work only when the Procuring Entity's Representative has given written instructions in advance for additional work to be paid for in that way.

11. Program of Work

- 11.1. The Contractor shall submit to the Procuring Entity's Representative for approval the said Program of Work showing the general methods, arrangements, order, and timing for all the activities in the Works. The submissions of the Program of Work are indicated in the **SCC**.
- 11.2. The Contractor shall submit to the Procuring Entity's Representative for approval an updated Program of Work at intervals no longer than the period stated in the **SCC**. If the Contractor does not submit an updated Program of Work within this period, the Procuring Entity's Representative may withhold the amount stated in the **SCC** from the next payment certificate and continue to withhold this amount until the next payment after the date on which the overdue Program of Work has been submitted.

12. Instructions, Inspections and Audits

The Contractor shall permit the GOP or the Procuring Entity to inspect the Contractor's accounts and records relating to the performance of the Contractor and to have them audited by auditors of the GOP or the Procuring Entity, as may be required.

13. Advance Payment

The Procuring Entity shall, upon a written request of the Contractor which shall be submitted as a Contract document, make an advance payment to the Contractor in an amount not exceeding fifteen percent (15%) of the total contract price, to be made in lump sum, or at the most two installments according to a schedule specified in the **SCC**, subject to the requirements in Annex "E" of the 2016 revised IRR of RA No. 9184.

14. Progress Payments

The Contractor may submit a request for payment for Work accomplished. Such requests for payment shall be verified and certified by the Procuring Entity's Representative/Project Engineer. Except as otherwise stipulated in the **SCC**, materials and equipment delivered on the site but not completely put in place shall not be included for payment.

15. Operating and Maintenance Manuals

- 15.1. If required, the Contractor will provide "as built" Drawings and/or operating and maintenance manuals as specified in the **SCC**.
- 15.2. If the Contractor does not provide the Drawings and/or manuals by the dates stated above, or they do not receive the Procuring Entity's Representative's approval, the Procuring Entity's Representative may withhold the amount stated in the **SCC** from payments due to the Contractor.

Section V. Special Conditions of Contract

Special Conditions of Contract

GCC Clause	
2	The Intended Completion Period is Ninety (90) Days <i>NOTE: The contract duration shall be reckoned from the start date and not from contract effectivity date.</i>
4.1	The Procuring Entity shall give possession of all parts of the Site to the Contractor beginning on the date of effectivity of contract until the date of its termination and/or project completion.
6	The site investigation reports are: Certificate of Site Inspection issued by the DSWD FO-X TWG.
7.2	<i>[In case of permanent structures, such as buildings of types 4 and 5 as classified under the National Building Code of the Philippines and other structures made of steel, iron, or concrete which comply with relevant structural codes (e.g., DPWH Standard Specifications), such as, but not limited to, steel/concrete bridges, flyovers, aircraft movement areas, ports, dams, tunnels, filtration and treatment plants, sewerage systems, power plants, transmission and communication towers, railway system, and other similar permanent structures:]</i> Fifteen (15) years.
10	Dayworks are applicable at the rate shown in the Contractor's original Bid.
11.1	The Contractor shall submit the Program of Work to the Procuring Entity's Representative within 90 days of delivery of the Notice of Award.
11.2	The amount to be withheld for late submission of an updated Program of Work is 1/50 of 1% of Contract Value.
13	The amount of the advance payment is 15% of the contract cost. Value can be availed of upon the submission and receipt of a request for the release of the advance payment after the issuance of the Notice to Proceed (NTP) and posting of an irrevocable letter of credit in favor of the Procuring Entity.
14	Progress payments shall be based on the "updated" Detailed Bill of Quantities based on the detailed cost estimates prepared and submitted by the Contractor during the design phase which is part of the submittals. Updating shall be limited only to minor items or sub-items not initially considered by the Contractor, but in no way shall "updating" changes the bid amount for each particular item. The Bill of Quantities as submitted by the Contractor during bidding process shall serve only for that purpose and shall not in any way become the basis for payment. Materials and equipment delivered on the site but not completely put in place shall not be included for payment.
15.1	The date by which operating and maintenance manuals are required is on/or before final billing (applicable to equipment installed). The date by which "as built" drawings are required is not later than 7 days after project completion or on/or before final billing.

15.2	No amount will be withheld for failing to submit “as built drawings” and/or operating and maintenance manuals and warranty certificate for all equipment within the date required. However, such documents will form part of the requirements in processing of final payment.
------	--

Section VI. Specifications

Specifications

Remodeling of a Portion of DRMD Warehouse to RROS and DRCC Offices

DIVISION 1.0 GENERAL CONDITIONS

PART 1.0 GENERAL

- 1.1 SCOPE OF WORK: The work covered under this Contract consists of the furnishing all materials, labor, equipment, transportation, incidentals, facilities, and superintendence necessary to complete the project in accordance with true intent these Specifications and Contract Drawings.
- 1.2. PLANS AND SPECIFICATIONS: The Contractor shall be responsible for carefully examining, comparing, and verifying the data furnished by the Plans and Specifications. In case of obscurity or discrepancy in the Plans and Specifications, the Contractor shall submit the matter to the Architect or his authorized representative for the proper explanation or necessary correction before any adjustment shall be made. Any adjustment by the Contractor without such determination shall be at his risk and expense.

Omitted or wrongly described details of work, which are manifestly necessary to carry out the true intent of the drawings and specifications, shall be performed as if fully and correctly set forth and described in the drawings and specifications.

The Owner may, from time to time, make changes in the specifications and construction drawings. However, if the cost to the Contractor shall be materially increased by such change, the Owner shall pay the Contractor for the reasonable cost in accordance with the changes. Changes stated herein shall be referred under Part 5 of General Conditions.

- 1.3 LAWS TO BE OBSERVED: The contractor shall comply with all the laws, City or Municipal Ordinances and all government Specifications and regulations in so far as they are binding upon or affecting the portion of the work hereto. The Contractor or those engaged thereon shall obtain all necessary licenses and permits and pay all taxes or fees, which may be due to the local and/or National Government in connection with the prosecution of the work. He shall also be responsible for all damages to persons or property that may occur.

PART 2.0 MATERIALS

- 2.1 MATERIALS: Unless otherwise specified, all materials shall be new and free from defects and imperfections. The quality of materials shall be of the best grade of their respective kinds for the purpose. The work shall be performed in the best and most acceptable manner in strict accordance with the requirements of the Plans and Specifications. Preference will be given to articles or materials that are locally manufactured, conditions of quality and price being equal.

2.2 SAMPLES AND INFORMATION ON MATERIALS: When required by the Specifications, or when called for by the Architect, the Contractor shall furnish, for approval, full Information, and satisfactory evidence as to the kind and quality of materials or articles he will Incorporate in the work. The Contractor shall furnish, for Architect's and Owner's approval, all samples when so directed. The work shall be in accordance with approved samples. Materials and articles installed or used without such approval shall be at the risk of subsequent rejection.

Any failure on the part of the Contractor to conform or use materials that are not specified herein shall be under subsequent rejection. Any alteration or revision of material usage without approval from the Architect shall make the Contractor responsible and liable in terms of guarantee, workmanship, and defects.

PART 3.0 WORKMANSHIP

3.1 WORKMANSHIP: Workmanship shall be in accordance with the best standard practices and all operations required under all parts of the Specifications shall be undertaken in a neat, sophisticated manner. Only skilled personnel with sufficient experience in similar operations shall be allowed to undertake the same.

Any alteration or revision on the execution of Drawings without approval from the Architect shall be under subsequent rejection and shall make the Contractor responsible and liable for any workmanship and execution defects.

Defective workmanship shall be remedied by the Contractor, at his expense. He shall not be entitled to any payment hereunder until defective workmanship has been remedied.

3.2 TEMPORARY FACILITIES: The Contractor shall provide and maintain adequate weather-tight temporary facilities with water, light, and toilet facilities. He shall keep such places clean and free from flies. He shall remove all connections and appliances connected there with prior to the completion of the Contract and leave the premises perfectly clean.

The Contractor shall furnish all temporary lights and power and shall pay all expenses in connection therewith. Furthermore, the Contractor shall provide and pay for all water expenses for building purposes that are required by all trades.

3.3 PROTECTION OF WORK AND OWNER'S PROPERTY: The Contractor shall put up safety measures and continuously maintain adequate protection of all his work from damage and shall protect the Owners property, as well as all materials furnished and delivered to him by the Owner. He shall make good any such damage, injury, or loss, except such as may be caused by agents or employees of the Owner, or due to causes considered as an Act of God.

3.4 DEMOLITION OF EXISTING STRUCTURES: The contractor shall ensure that proper ventilation and noise comfort is provided for workers during demolition works.

PART 4.0 SUPERVISION AND INSPECTION

- 4.1 **AUTHORIZED REPRESENTATIVE:** Whenever the Contractor is not at the site, orders may be given by the Owner to his authorized representative and shall be accepted and complied to by the superintendent or foreman of the Contractor.
- 4.2 **INSPECTION OF WORK:** The Architect, Engineer, or Owner shall, at all times, have access to the work whenever it is in preparation or progress and the Contractor shall provide facilities for such access for inspection. The manner of work and all materials and equipment used therein shall be subject to inspection, tests, and approval of the Owner.
- 4.3 **CONSTANT SUPERVISION.** The Contractor shall ensure that the project will have constant supervision by a competent superintendent, who shall be present where construction is being always carried on during the working hours.
- 4.4 **DISPUTES:** The Architect shall, within a reasonable time, make decision on all claims of the Owner or Contractor and on all matters relating to the execution and progress of the work or the interpretation of the Contract Documents.

Except as otherwise specifically provided in this Contract, all disputes concerning questions of fact arising under this contract shall be decided by the Architect, whose decisions shall be final and conclusive upon the parties as to questions of fact.

- 4.5 **CLEAN UP:** The Contractor, prior to the turnover of the work to the Owner, shall remove any excess materials, waste, debris, rubbish, and all construction and installation equipment and tools from the premises.

PART 5.0 VARIATION ORDERS

Legal Basis: 2016 IRR Annex "E" provides the rules in relation to Variation Orders.

- 5.1 **VARIATION ORDER:** Increase or decrease in quantities within the general scope of the project as bid and awarded by introduction of new work that are not originally included in the contract; or reclassification of work items that are either due to change of plans, design, or alignment to suit actual field conditions resulting in disparity between the pre-construction plans used for the purposes of the bidding and the "as staked plans" or construction drawings prepared after joint survey by the Contractor and the Owner after the award of the contract, or during actual construction.

Any changes in materials required by the Owner, or addition of works for the project, shall be in any cases should not exceed the amount as indicated with the Contract amount and pre-construction plans, except only when the said changes are necessary for the completion of the Project as a whole.

The addition/deletion of works should be within the general scope of the project as bid and awarded, and the deletion of the work should not affect the integrity and usefulness of the structure.

- 5.2 ISSUANCE: Variation order may be issued by the Procuring Entity concerned at any time during contract implementation. However, the adjustment provided for in these orders must be necessary to fully meet the requirements of the project. The issuance of a Variation Order must imply that there will not be any shortchanges in the original design; that it will not affect the structural integrity and usefulness of the structure; and that it will be covered by a Certificate of Availability of Funds (CAF).

Under no circumstances can a contractor proceed to commence work under any Change Order or Extra Work Order unless the Head of Procuring Entity (HoPE) or his/her duly authorized representative has approved the order. The Procuring Entity's representative/ Engineer / Architect may, subject to the availability of funds and within the limits of his delegated authority, authorize the immediate start of work under any Change Order or Extra Work Order, subject to any event of any emergency where the prosecution of the work is urgent to avoid any detriment to public service, or damage to life and/or property; and/or when time is of the essence.

- 5.3 AMOUNT: The net cumulative amount of the Variation Order should not exceed positive Ten Percent (+10%) of the original contract cost. The scope of work, however, shall not be reduced as to accommodate a positive Variation Order.

For additional/extra works duly covered by Change Orders involving work items which are the same or similar to those in the original contract, the applicable unit prices of work items in the original contract shall be used.

For additional/extra works duly covered by Extra Work Orders involving new work items that are not in the original contract, the unit prices of the new work items shall be based on the direct unit costs used in the original contract (*e.g.*, unit cost of cement, rebars, form lumber, labor rate, equipment rental, etc.). All new components of the new work item shall be fixed prices, provided the same is acceptable to both the government and the contractor. The direct unit costs of new components must also be based on the contractor's estimate as validated by the Procuring Entity via documented canvass in accordance with existing rules and regulations. The direct cost of the new work item must then be combined with the mark-up factor (*i.e.* taxes and profit) used by the contractor in his bid to determine the unit price of the new work item.

The request for payment by the contractor for any extra work must be accompanied by a statement, with the approved supporting forms, giving a detailed accounting and record of amount for which he claims payment. This request for payment must be included in the contractor's statement for progress payment.

-----END OF SECTION-----

DIVISION 2.0 SITEWORK

SECTION 2.01 EARTHWORK

PART 1.0 GENERAL

- 1.1 **WORK INCLUDED:** Work in this section includes the complete clearing of site, general site grading, excavating, filling and backfilling.

PART 2.0 DEGREE OF COMPACTION

Required compaction is expressed as a percentage of the maximum density obtained by test procedure of ASTM D1557.

- 2.1 **EXCAVATION:** The contractor shall perform excavation of every type of material encountered within the limits of the project to the lines, grades, and elevations indicated and as specified herein. Grading shall be in conformity with the typical sections shown and shall be finished within a tolerance of 25/100 foot of the grades indicated. Satisfactory excavated materials shall be transported to and placed in fill areas within work limits. Unsatisfactory materials encountered below the established sub-grade shown under building or paved areas shall be excavated 300 mm or 31 cm below grade and replaced with satisfactory materials as directed. In the event that it is required to remove unsatisfactory material to a greater depth than specified, an adjustment in the contract price will be made in accordance with the contract. Surplus satisfactory excavated material not required for fill or embankment shall be disposed of to the designated waste or spoil areas. Unsatisfactory excavated material shall be disposed of in designated wastes or spoil areas. Excavation and filling shall be performed in manner and sequence that will always provide proper drainage.
- 2.2 **CUTTING, FILLING AND GRADING:** Cutting, filling and grading will be done to bring all areas of the respective surfacing as fixed by the finished grade.
- 2.3 **COMPACTION:** Compaction shall be by rolling with approved tamping rollers, vibratory rollers, pneumatic-tired rollers, three-wheel power rollers, or other approved equipment well suited to the particular soil being compacted. Material shall be moistened or aerated as necessary to provide the moisture content that will facilitate obtaining the specified compaction with the equipment utilized. 0

PART 3.0 SUB-GRADE PREPARATION

- 3.1 **CONSTRUCTION:** Sub-grade shall be shaped to line, grade, and cross-section, and compacted as specified. This shall be done by plowing, disking, and moistening or aerating. Low areas resulting from removal of unsatisfactory material or excavation of rock shall be brought up to required grade with satisfactory materials, and entire sub-grade shaped. Elevation of finish sub-grade shall conform to elevations shown.
- 3.2 **PROTECTION:** During construction, any excavation shall be kept shaped and drained. Ditches and drains shall be maintained in such manner as to drain effectively at all times. Graded areas shall be protected against action of the elements prior to acceptance of the work. Settlement or washing that may have occurred shall be repaired

and grades shall be re-established to the required elevations and slopes immediately prior to installation of paving.

PART 4.0 EXCAVATION, FILLING, AND BACKFILLING FOR BUILDING

- 4.1 GENERAL: Excavations shall conform to dimensions and elevations indicated for the building structure and shall extend a sufficient distance from walls and footings to services, except where the concrete for walls and footings is authorized to be deposited directly against excavation surfaces. Bottoms of all footings shall be on level planes.
- 4.2 EXCESS EXCAVATION: Excavations carried below indicated depths will not be permitted except to remove unsatisfactory material. Unsatisfactory materials encountered below grades shown shall be removed and replaced as directed with satisfactory materials. Unauthorized material removed below depths indicated shall be replaced, at no additional cost to the owners, to the indicated excavation grade with satisfactory materials placed and compacted to 100% maximum density except under concrete footings.
- 4.3 DRAINAGE AND PUMPING: Excavate in such a manner that site and area immediately surrounding will be continually drained. Water shall not be permitted to accumulate in excavations. Do all necessary pumping required to keep excavations dry.
- 4.4 SHORING: During excavation shall be furnished and installed as necessary to protect workers, banks, adjacent paving, structures, and utilities. Shoring, bracing, and sheeting shall be removed, as excavations are backfilled in such a manner as to prevent injurious caving.
- 4.5 EXCAVATED MATERIALS: Satisfactory excavated materials required for fill or backfill shall be separately stockpiled as directed. Unsatisfactory and surplus excavated materials not required for fill and backfill shall be disposed of in designated waste area. Stockpiles and wasted materials shall be graded and sloped for proper drainage.
- 4.6 BACKFILLING: Backfilling shall not begin until construction below finish grade has been approved, underground utilities systems have been inspected, tested, and approved, formed removed, and the excavation cleaned of trash and debris. Backfill shall be brought to indicated finish sub-grade. Backfill materials shall be satisfactory materials, free from roots and other organic matter, trash, debris. Place backfill in 23-cm maximum layers loose depth. Compaction shall be as in Paragraph 2A.5. Fill shall be compacted by power-driven hand tampers suitable for the material being compacted. Backfill shall not be placed against foundation walls prior to 7 days after placement of concrete or masonry. As far as practicable, backfill shall be brought up evenly on each side of the wall and sloped to drain away from the wall. Brace inside of the wall before earthfill is placed on the outside of basement.
- 4.7 PROTECTION: Settlement that occurs in backfill areas prior to acceptance of the work shall be repaired and grades re-established to the required elevation and slope.

-----END OF SECTION-----

DIVISION 3.0 CONCRETE

SECTION 3.01 CAST-IN-PLACE CONCRETE

PART 1.0 GENERAL

1.1 SCOPE. This section covers cast-in-place concrete, complete.

1.2 DELIVERY AND STORAGE

A. CEMENT: Cement shall be stored immediately upon receipt at the site of the work in a suitable weatherproof and airtight structure and elevated above the ground to prevent the absorption of moisture. Bags shall be stacked close together to reduce circulation of air but shall not be stacked against outside walls. The manner of storage shall permit easy access for inspection and identification of each shipment. Bulk cement shall be transferred to elevated airtight and weatherproof bins. At the time of use, all cement must be free flowing, and free of lumps. Cement that has been in storage for longer than 6 months will be tested by standard mortar tests or other tests as deemed necessary by the Construction Architect or Engineer to determine its suitability for use.

B. AGGREGATES: Aggregates shall be stored in areas covered with tightly laid wood planks, sheet metal or other hard and clean surface, and in a manner that will preclude the inclusion of foreign materials. Aggregates of different sizes shall be stored in separate piles.

C. REINFORCEMENT: Reinforcement shall be stored in such a manner that will prevent excessive rusting or coating with grease, oil, dirt, and other objectionable materials. Storage shall be in separate piles or racks to avoid confusion and loss of identification after bundles have been broken.

PART 2.0 MATERIALS

2.1 CEMENT: Portland cement shall conform to PNS 07, type 1. Cement for exposed concrete surfaces shall be from the same mill.

2.2 REINFORCEMENT: All reinforcing steel bars, except No. 2, shall be deformed. The manufacturer shall submit certification of compliance to this specification prior to the delivery of these materials.

2.3 FINE AGGREGATES: Fine aggregates shall be clean, hard, natural sand or manufactured sand, or a combination of both.

2.4 COARSE AGGREGATES: Coarse aggregates shall be hard, durable, uncoated gravel, crushed gravel, or a combination thereof.

2.5 WATER: Mixing water for concrete shall be fresh, clean, and potable.

- 2.6 CURING MATERIALS: Materials shall conform to one of the following unless otherwise designated:
- a. Polyethylene sheeting for curing, 6 mils minimum thickness, clear.
 - b. Waterproof paper or polyethylene-coated waterproof paper for concrete curing shall be of commercial quality.
 - c. Burlap, plain or polyethylene-coated burlap shall be of commercial quality.
- 2.7 EXPANSION JOINT'S FILLER: shall be elastomeric pre-molded type.
- 2.8 SEALING MATERIALS: for expansion joints shall be single component urethane or acrylic type sealant.
- 2.9 FORMS COATING: shall be non-staining type mineral oil.
- 2.10 VAPOR BARRIER: shall be a polyethylene sheet, 6 mils minimum thickness, clear, conforming to commercial standard CS-238.
- 2.11 WATER – STOP: (if applicable) shall be rubber, neoprene or PVC.

PART 3.0 FORMS

- 3.1 GENERAL REQUIREMENTS: Forms shall be provided for all concrete. Forms shall be set true to line and grade and maintained as to ensure completed work within the allowable tolerance specified and shall be mortar tight. The contractor shall be responsible for the adequacy of forms and form support. Wire ties shall not be used where the concrete surface will be exposed to weathering and where discoloration will be exposed. All formworks shall be provided with adequate clean-out openings to permit inspection and easy cleaning after all reinforcement has been placed. Where forms for continuous surfaces are placed in successive units, these shall be fitted over the completed surface to obtain accurate alignment of the surface and to prevent leakage of mortar. Panel forms shall be constructed to provide tight joints between panels. All forms shall be constructed so that they can be removed without damaging the concrete. All exposed joints, edges and external corners shall be chamfered a minimum of 20 mm unless specified otherwise hereinafter.
- 3.2 MATERIALS FOR FORMS: Forms shall be of wood, plywood, steel, or other suitable materials. Wood forms for surfaces exposed to view in the finished structure and requiring a standard finish, shall be plywood. For unexposed surface, undressed square-edged lumber may be used. Forms for surfaces requiring special finishes shall be plywood or hard-pressed fiberboard not less than 12 mm thick. Surfaces of steel forms shall be free from irregularities, dents, and sags.
- 3.3 COATING: Before placing the concrete, the contact surfaces of forms shall be coated with non-staining mineral oil or suitable non-staining form coating compound, or shall be given two coats of nitrocellulose lacquer, except as specified otherwise. Mineral oil shall be used on forms for surfaces, which are to be painted. For surfaces not exposed to view in the finished structure and when temperature is above 40 °F, sheeting may be wetted thoroughly with clean water. All excess coating shall be removed by wiping with cloths. Re-used forms shall have the contact surfaces cleaned thoroughly; those, which have been coated, shall be given an additional application of the coating. Plaster

waste molds shall be sized with two coats of thin shellac or lacquer and coated with soft or thinned non-staining grease.

- 3.4 TOLERANCE AND VARIATIONS: The contractor shall set and maintain concrete forms to ensure that after removal of the forms and prior to patching and finishing, no portion of the concrete work will exceed any of the tolerances specified. Variation in floor levels shall be measured before removal of supporting shore. The contractor shall be responsible for variations due to deflection. The specified variation for one element of the structure will not be applicable when it will permit another element of the structure to exceed its allowable variations. Except as otherwise specified hereinafter, tolerances.

Type of Structure	Tolerance ± (in mm)
Footings	32
Columns	25
Slab	25
Lintel Beams	40
Stiffener Columns	40
Anchorage/ Bolts	3

PART 4.0 CLASSES OF CONCRETE

- 4.1 STRENGTH REQUIREMENTS. Concrete of the various classes, if not indicated in the drawings and as specified under other sections, shall be proportioned and mixed for the following strengths:

CLASS A	SPECIFIED COMPRESSIVE STRENGTH, 28 Days, (Psi)
AA	4,000
A	3,000
B	2,500
C	2,000
P	600

Concrete made with high-early-strength cement shall have a 7-day strength equal to the specified 28-day strength for concrete of the class specified made with type I or II Portland cement.

- 4.2 USAGE. Concrete of the various classes shall be used as follows:
- a. Class AA concrete - For water storage tanks, septic tanks and other work as indicated.
 - b. Class A concrete - For pre-cast concrete items, slabs, beams, and walls above grade, columns, stairs, lintels, and for all reinforced work not otherwise indicated or specified.
 - c. Class B concrete - For slabs and grade, grade and tie beams, footings, and for such concrete work as indicated or specified.
 - d. Class C concrete - For all concrete not reinforced except as otherwise indicated or specified.
 - e. Class P concrete - For slabs on grade subject to vehicular load and as indicated or specified.

PART 5.0 PROPORTIONING, MEASUREMENT AND MIXING

5.1 CONCRETE DESIGNS MIX: Concrete mixes except otherwise indicated shall be designed by the contractor. The proportions shall be changed whenever necessary to maintain the workability, strength, and standard of quality core the concrete covered by these specifications, and to meet the varying conditions encountered during construction. Test for slump and unit weight shall be performed under the supervision of the Construction Architect/Engineer.

5.2 SLUMP: shall be determined in conformance with ASTM C 143, and shall be within the following limits, provided the required strength is obtained:

STRUCTURAL ELEMENT	SLUMP FOR VIBRATED CONCRETE	
	Minimum	Maximum
Walls, columns, and grade beams, 250 mm. Maximum thickness	75mm	100mm
Other construction	50mm	75mm

5.3 PROPORTIONING OF MATERIALS: shall be accomplished by weighing, except as otherwise provided herein. In urgent situation, volumetric proportioning may be used temporarily, if permitted by the Construction Architect/Engineer, who will stipulate the length of the period during which volumetric proportioning may be used. The contractor shall furnish the necessary equipment and shall establish accurate procedures for determining the quantities of free moisture in the aggregates, the true volume of the fine aggregate if volumetric proportioning is used, and the air content of the freshly mixed concrete if air-entrained concrete is used. Such procedures are subject to the approval of the Construction Architect/Engineer. Moisture, volumetric and air determinations shall be made at intervals as directed by the Construction Architect/Engineer and as specified hereinafter under field testing requirements. Allowable tolerances for measuring cement and water shall be one (1%) percent; for aggregates, two (2%) percent; and three (3%) percent for mixtures.

5.4 WEIGHT MEASUREMENT: The fine aggregate and each size of coarse aggregate shall be weighed separately. Cement in standard packages (bags) need not be weighed, but bulk cement or fractional packages shall be weighed on a scale separate from that used for weighing other materials.

5.5 VOLUMETRIC MEASUREMENT: The weight proportions shall be transposed into equivalent volumetric proportions by weighing representative samples of the aggregates in the conditions in which they will be measured and in accordance with ASTM C29. In determining the true volume of the fine aggregate, allowance shall be made for the bulking effect from the moisture contained therein. Suitable allowances shall also be made for variations in the moisture conditions of the aggregates.

- 5.6 MIXING: All concrete shall be machine mixed. In cases of emergency or small batches, the mixing may be done by hand if was authorized by the Construction Architect/ Engineer. Mixing shall begin within 30 minutes after the cement has been added to the aggregates. The time of mixing after all cement and aggregates are in the mixer drum shall be not less than one minute for mixers having a capacity of one cubic yard or less; for mixers of larger capacities, the minimum time shall be increased 15 second for each additional cubic yard. A reduction in the mixing time shall be permitted if mixer performance tests made at the contractor's option and at his expense, indicate adequate mixing with the reduced time. All mixing water shall be introduced in the drum before one-fourth of the mixing time has elapsed. The entire content of the mixer drum shall be discharged before recharging. The time elapsing between the introduction of the mixing water to the cement and aggregates or the cement to the aggregates and placing of the concrete in final position in the forms shall not exceed 60 minutes, if the air temperature is less than 85 degrees Fahrenheit. If the air temperature is equal or greater than 85 degrees Fahrenheit, time elapsed shall not exceed 45 minutes. The re-tampering of concrete, i.e., re-mixing with or without additional cement, aggregate or water, will not be permitted.
- 5.7 READY-MIXED CONCRETE. Ready-mixed concrete is defined in this specification as concrete produced regularly by a commercial establishment and delivered to the purchaser in the plastic state. Subject to the approval of the Construction Architect/Engineer, ready-mixed concrete may be used provided that (a) the plant has sufficient capacity and transportation equipment to deliver the concrete at the rate desired, and (b) the plant meets the requirements specified for equipment, measurement of materials, and mixing. The cement, aggregates, water and admixtures shall conform to all applicable requirements of this specification. Ready-mixed concrete not specified otherwise hereinafter shall be mixed and delivered by means of the following methods:
- a. TRUCK MIXING: Concrete shall be mixed and delivered in a truck mixer. Mixers shall be charged with a ribbon-fed mixture of aggregates and cement, or in the absence of facilities for ribbon feeding, the aggregates shall be charged before the cement. When mixing has begun during or immediately after charging, a portion of the mixing water not in excess of that required to produce the minimum acceptable slump shall be added ahead of or with the other ingredients. Total mixing shall not be less than 50, but not more than 100 revolutions of the drum at the manufacturer's rated mixing speed after all ingredients, including water, are in the drum. After 30 to 75 revolutions of the drum, the slump shall be tested and additional water shall be added if necessary to produce the required slump; if additional water is necessary, mixing shall be continued for at least 20 revolutions of the drum after the water is added. Mixing speed shall not be less than rpm for revolving drum mixers, and not less that 4 rpm nor more than 16 rpm for open-top mixers. Any turning of the drum during transportation shall be at the speed designated by the manufacturer of the equipment, as agitating speed. Each batch of concrete delivered at the job site shall be accompanied by a time slip issued at the batching plant, bearing the time of departure therefrom and the signature of the inspector. Discharge of concrete from the drum shall be completed within 1 hour or before the drum completes 250 revolutions after the introduction of water to the cement and aggregates.
 - b. COMBINATION CENTRAL PLANT AND TRUCK MIXING: (Shrink Mixing). Concrete shall be partially mixed in a central plant mixer and the mixing completed in a truck mixer. The mixing time in a central plant mixer shall be the minimum required to intermingle the ingredients and shall not exceed 30

- seconds. The mixing shall be completed in a truck mixer as specified herein before under truck mixing.
- c. CENTRAL PLANT MIXING: Concrete shall be mixed completely in a stationary mixer at a plant and transported to the site of the work in a truck agitator or a truck mixer operating at a speed of rotation designated by the manufacturer as agitating speed. Mixing shall begin within 30 minutes after cement has been added to aggregates. When authorized in writing by the Construction Architect/Engineer non-agitation equipment approved by him may be used for transporting concrete. The time lapse between the introduction of the mixing water to the cement and aggregates and the placing of concrete in final position in the forms shall not exceed: (a) for agitating equipment - 60 minutes, if air temperature is less than 80 degrees F. or 45 minutes, if air temperature is equal or greater than 85 degrees F., (b) for non-agitating equipment - 30 minutes.
 - d. CONSISTENCY OF CONCRETE: Except as specified otherwise, the slump shall be from 50 mm to 100 mm.

PART 6.0 PLACING REINFORCEMENTS AND MISCELLANEOUS MATERIALS

- 6.1 GENERAL REQUIREMENTS: All reinforcement bars, stirrups, hanger bars, wire fabric, spiral, and other reinforcing materials shall be provided as indicated on the drawing or required by this specification, together with all necessary wire ties, chairs, spaces, supports and other devices necessary to install and secure the reinforcement properly. All reinforcement, when placed, shall be free from rust, scales, oil, grease, clay, and other coatings, and foreign substances that would reduce or destroy the bond. Rusting of reinforcement shall not be a basis of rejection, provided that the rusting has not reduced the effective cross-sectional area of the reinforcement to the extent that the strength is reduced beyond specified value. Heavy, thick rust or loose, flaky rust shall be removed by rubbing with burlap or other approved method, prior to placing. Reinforcement, which has bends not shown on the project drawings, approved shop drawings, or is reduced in section by rusting such that its weight is not within permissible ASTM tolerances, shall not be used. All reinforcement shall be supported and wired together to prevent displacement by construction loads or by the placing of concrete. Unless directed otherwise by the Construction Architect/Engineer, reinforcement shall not be bent after being partially embedded in hardened concrete. Where cover over reinforcing steel is not specified it shall be in accordance with ACI 318.
- 6.2 PLACING: Reinforcement shall be placed accurately and secured. It shall be supported by suitable chairs or spacers or by metal hangers. On the ground, and where otherwise subject to corrosion, concrete or other suitable non-corroding material shall be used for supporting reinforcement. Where the concrete surface will be exposed to the weather in the finished structure or where rust would impair the appearance or finish of the structure, all reinforcement supports, within specified concrete cover, shall be galvanized or made of a suitable non-corroding material.
- 6.2 SPLICING OF REINFORCEMENT: Splicing of reinforcement shall be in accordance with ACI 318, except as indicated otherwise or modified herein. Where splices in addition to those indicated on the drawings are necessary, they shall be approved by the Construction Architect/Engineer prior to their use. Splices shall not be used in grade beams and slabs at points of maximum stress. Except as indicated or specified otherwise

herein, in lieu of lapping, but splicing of reinforcement may be permitted provided the splicing material, equal or greater in cross sectional area to the spliced steel, shall possess a minimum of 125 percent of the yield strength or 90 percent of the ultimate strength of the reinforcing steel, whichever is the greater. But splicing shall preferably use over lapping for bar sizes No. 11 and above.

- 6.3 MOVING REINFORCING STEEL: All placement or movement of reinforcing steel after placement to positions other than that indicated or specified shall be subject to the approval of the Construction Architect/Engineer,
- 6.4 SETTING MISCELLANEOUS MATERIAL: Anchors and bolts, including, but not limited to those for machine and equipment bases, frames or edgings, hangers and inserts, door bucks, pipe supports, pipe sleeves, metal ties, conduits, drains and all other materials in connection with concrete construction, shall, where practicable, be placed and secured in position when the concrete is placed. Anchor bolts for machines shall be set to templates, plumbed carefully and checked for location and elevation with an instrument, and shall be held in position rigidly to prevent displacement while concrete is being placed.

PART 7.0 CONVEYING AND PLACING CONCRETE

- 7.1 CONVEYING: Concrete shall be conveyed from the mixer to the forms as rapidly as practicable by proper methods, avoiding segregation or loss of ingredients. It shall be deposited as nearly as practicable in its final positions in the forms. At any point in the conveying, the free vertical drop of the concrete shall not exceed 91 cm. Chuting will be permitted only where the concrete is deposited into a hopper before it is placed in the forms. Conveying equipment shall be cleaned thoroughly before each run. All concrete shall be deposited as soon as practicable after the forms and reinforcements have been inspected and approved by the Construction Architect/Engineer. Concrete, which has been segregated in conveying, shall be removed, and disposed of as directed by the Construction Architect/Engineer.
- 7.2 PLACING CONCRETE: No concrete shall be placed after there is evidence of initial set. All concrete placing equipment and methods shall be subject to approval of the Construction Architect/Engineer. Concrete placement will not be permitted when weather conditions prevent proper placement and consolidation. Before placing concrete on porous sub-grades, they shall be dampened as directed by the Construction Architect/ Engineer. Forms shall be clean and free from dirt, construction debris and water. Concrete shall be deposited in horizontal layers approximately 31 to 51 cm deep in a manner to preclude the formation of cold joints between successive layers. The method of depositing concrete shall be such as to avoid displacing the reinforcement and segregating the aggregate. Concrete shall be worked about the reinforcement and embedded fixtures and avoid overworking which may result in segregation. On the bottom of slabs, the girders where the congestion of steel near the forms makes placing difficult, a layer of mortar equal to the approved slump shall be deposited to cover the surface to a depth of approximately 25 mm before placing the concrete. Water, which accumulates on the surface of the concrete during placing, shall be removed by absorption with porous materials in a manner that prevents removal of cement. Pumping of concrete through aluminum pipe shall not be permitted.

- 7.3 VIBRATION: All concrete, except for concrete slabs 100 mm or less in depth, shall be compacted using high frequency, internal, mechanical vibrating equipment supplemented by hand spading and tamping. Concrete slabs 100 mm or less in depth shall be consolidated by wood tamper and spading and settling with a heavy leveling straight edge. Vibrator shall be designated to operate with vibratory element submerged in the concrete and shall have a frequency of not less than 6,000 impulses per minute when submerged. The vibrating equipment shall be always adequate in number units' power of each unit to consolidate the concrete properly. Vibration of forms and reinforcement shall not be employed except when authorized specifically the Construction Architect/Engineer. Vibrators shall not be used to transport the concrete in the forms. Vibration shall be discontinued when the concrete has been compacted thoroughly and ceased to decrease in volume.
- 7.4 CONSTRUCTION JOINTS: Joints not shown on the drawings shall be made and located so as to least impair the strength of the structure and shall be subject to approval of the Construction Architect/Engineer. In general, they shall be located near the middle of the spans of slabs, grade beams. Horizontal joints in walls shall be at the underside of floor, slabs, grade beams, or girders and at the top of footings or grade slabs. Grade beams, brackets, and drop panels shall be placed at the same time as slabs. Joints shall be perpendicular to the main reinforcement. All construction joints in contact with the grade or earth shall be provided with an approved type of rubber or PVC water-stop to minimize water leakage. Water-stop shall be installed so as to form a continuous watertight diaphragm. Joints and splices shall be vulcanized or heat-sealed and as recommended by the manufacturer as approved.
- a. Reinforcement in construction joints. All reinforcing steel shall be continued across joints. Keys and inclined dowels shall be provided as directed by the Construction Architect/Engineer. Longitudinal keys at least 38 mm deep shall be provided in all joints in walls and between walls and slabs or footings.

7.5 EXPANSION JOINTS AND CLEAVAGE JOINTS.

- a. Expansion joints and cleavage joints shall not be less than 12 mm wide except as indicated otherwise. Expansion joints not exposed to weather shall be filled completely with pre-formed joint materials. Expansion joints exposed to weather and cleavage joints between vertical masonry surfaces and floor slabs lay on earth shall be filled to a depth of 25 mm from the surface or face of the concrete with pre-formed joints' material. The 25-mm deep space above the performed material shall be cleaned after the concrete has been cured, and when dry, filled with flush with joint-sealing material. Reinforcement or the embedded metal items bonded to the concrete shall not be permitted to extend continuously through any expansion joints.
- b. Sealing materials for expansion joints shall be single component urethane sealant or equal.
- c. Other embedded items. All sleeves, inserts, anchors, and embedded items required for adjoining work or for its support shall be placed prior to concreting. All subcontractors whose work is related to the concrete supported by it shall be given ample notice and opportunity to introduce or furnish embedded item before the concrete is placed. All ferrous metal sleeves, inserts, anchors and other embedded ferrous items exposed to the weather or where rust would impair the appearance of finish, or the structure shall be galvanized.

- 7.6 PLACING EMBEDDED ITEMS: Expansion joint material and embedded items shall be positioned accurately and supported against displacement. Voids in sleeves, inserts and anchors' slab shall be filled temporarily with readily removable material to prevent the entry of concrete into the voids.
- 7.7 PLACING CONCRETE IN HOT WEATHER: Placing concrete in hot weather shall be in accordance with ACI305 except as modified herein. In hot weather, extra care shall be taken to reduce the temperature of the concrete being placed, and to prevent rapid drying of newly placed concrete. When the outdoor ambient temperature is more than 90 degrees F., the fresh concrete shall be shaded as soon as possible after the placing and curing shall be started as soon as the surface of the fresh concrete is sufficiently hard to permit it without damage.

PART 8.0 SLABS ON GRADE.

- 8.1 VAPOR BARRIER: Immediately prior to placing concrete, the capillary water barrier or sub-grades under slabs within the building shall be covered with vapor barrier. Puncture and tear shall be patched. Edges shall be lapped not less than 100 mm and end joints shall be lapped not less than 150 mm. Edges and lapped joints shall be sealed with a pressure-sensitive tape, not less than 50 mm wide, compatible with the membrane.

PART 9.0 SURFACE FINISH (EXCEPT FLOOR FINISH)

- 9.1 GENERAL REQUIREMENTS: All formed surfaces shall be repaired by patching with cement mortar. Cement mortar for patching shall be the same composition as that used in the concrete, except that for exposed surfaces' part of the cement shall be white Portland cement to provide a finish color matching the surrounding concrete. Patching shall be done as soon as the forms are removed area to surfaces which are to be cured with a curing compound shall be covered during the application of the compound. All areas to be patched shall be cleaned thoroughly. Minor honeycomb or otherwise defective areas shall be cut out to solid concrete but to a depth of not less than 25 mm. The edges of the cut shall be perpendicular to the surface of the concrete. The area to be patched and at least 150 mm adjacent hereto shall be saturated with water before placing the mortar. The mortar shall be mixed approximately one hour before placing and shall be re-mixed occasionally during this period with a trowel without the addition of water. A grout of cement and water mixed to a consistency of paint shall then be brushed on to the surfaces to which the mortar is to be bonded. The mortar shall be compacted into place and screeded slightly higher than the surrounding surface. Patches on exposed surface shall be finished to match the adjoining surfaces, after they have set for an hour or more. Patches shall be cured as specified for the concrete. Holes extending through the concrete shall be filled by means of a plunger type gun or other suitable device from the unexposed face. The excess mortar shall be wiped off the exposed face with a cloth. Finished surfaces shall be protected from stains and abrasions. Standard finish against steel, plywood and wood forms shall be equal in workmanship, texture, and general appearance to that of approved sample panels. Concrete with excessive honeycombing, which exposes the reinforcing steel or other defects affecting the structural strength of the member will be rejected and the

defects shall be corrected as directed by the Construction Architect/Engineer, and at the expense of the contractor.

- 9.2 RUBBED-FINISH: Rubbed finish shall be provided for all exposed concrete beams and ceiling. The surface of the concrete shall not vary more than 16 mm when measured from a five-foot template. Exposed surfaces shall be rubbed with carborundum or other abrasives to a smooth even finish or uniform appearance. Upon completion of the rubbing, the surface shall be washed thoroughly with clean water.
- 9.3 BROOM-FINISH: Broom-finish shall be given to exterior parking area or as approved. The concrete shall be screeded and floated to the required finish level with no coarse aggregate visible. After the surface moisture has disappeared and laitance has been removed, surface shall be steel trowelled to an even, smooth finish. The trowelled surfaces shall be broomed with a fiber-bristle brush in a direction traversing to that of the main traffic.

PART 10.0 FLOOR FINISHES

- 10.1 GENERAL REQUIRMENTS: The finishes included herein shall be surface finishes and treatments for floor slab. Concrete toppings except where indicated shall not be allowed for all floor slabs having steel-trowel finish. For roof deck floors in which drains occur, special care shall be exercised to slope the floors uniformly to the drains. Deck roof floors shall receive single steel trowelling prior to the application of waterproofing.
- 10.2 PLACING AND SCREEDING NORMAL CONCRETE SLAB OR BASE SLAB: Concrete of slump within the limits specified herein before shall be placed, consolidated, and immediately struck off to bring the top surface of the slab to proper contour, grade elevation. This operation may be followed immediately by a “darbying: or bull floating of the surface with wooden tools to correct any unevenness. Striking off and darbying shall be completed before bleed water appears on the surface of the freshly placed concrete. No further work shall then be performed until the concrete has attained a set sufficient for floating and sufficient to support the weight of the finisher and/or equipment. If the bleed water has not disappeared by the time floating of the surface is to start, the excess water shall be first dragged off on the surface by using a rubber hose. At no time shall dry cement will be used to absorb bleed water.
- a. ROUGH-FINISH: shall be provided for all floors to receive future floor finish, which will be provided by tenants. Allow 50 mm below finish floor line.
 - b. NON-SLIP FINISH: shall be provided for ramps allocated for disabled persons. Type of finish shall be as approved.
- 10.3 CLEANING: Upon completion of the work, all concrete floors shall be cleaned as follows: after sweeping with an ordinary broom to remove the loose dirt, the finish surface shall be wetted with soap suds and rubbed with a scrubbing machine fitted with a wire brush or fine steel wool. The suds shall be mopped up, and the surface shall be flushed with clean warm water, after which a final scrubbing by hand instead of the machine scrubbing will be permitted when authorized specifically.

PART 11.0 CURING

- 11.1 GENERAL REQUIREMENTS: Curing for all concrete shall be accomplished by preventing loss of moisture, rapid temperature change, mechanical injury, or injury from rain or flowing water for a period of Seven (7) days when normal Portland cement has been used. Curing shall be started as soon after placing and finishing as free water has disappeared from the surface of the concrete. Curing may be accomplished by any of the following methods or combination thereof, as approved.
- 11.2 MOIST CURING: Unformed surfaces shall be covered with burlap or other approved fabric-type mats and shall be kept continually wet. Forms shall be kept continually wet. If forms are removed before the end of the curing period, curing shall be continued on unformed surfaces that will be unexposed in the finished work.
- 11.3 IMPERVIOUS SHEET CURING. Surfaces shall be covered with waterproof paper, polyethylene coated waterproof paper or burlap, or polyethylene sheets, lapped 100 mm at edges and ends, and sealed with an adhesive tape suitable for the type of covering used. The covering shall be weighed to prevent displacement and kept in place and in repair during the curing period.
- 11.4 CURING PERIODS: When 7-day compression test cylinders, representative of parts of a structure already placed, indicate that the 28-day strengths may be less than 90% of the design strengths, those parts of the structure shall be given additional curing, as directed by the Construction Architect/Engineer. Curing shall be as follows:

TIME (Minimum)	CONCRETE ELEMENT
7 Days	All concrete not specified otherwise
10 Days	Pavement not undercover

- 11.5 REMOVAL OF FORMS AND PROTECTION: Forms shall be removed in a manner, which will prevent damage to the concrete. Forms shall not be removed without approval of the Construction Architect/Engineer.

PART 12.0 SAMPLING

- 12.1 CONCRETE: The strengths specified and the design mix shall be verified during the progress of the work at intervals by testing standard cylinders of samples taken at the job site.

Three test cylinders shall be taken for each 60 cubic meter or fraction thereof of each class of concrete placed, but at least test cylinders shall be taken each day for each class of concrete placed that day, or as directed by the Construction Architect/Engineer. No more than 3 cylinders shall be taken from any one batch. The contractor shall furnish the work and labor, materials, and facilities for taking the samples, handling, storing the cylinders at the site of the work, and shipping the cylinders for testing to the authorized and designated testing laboratory at his expense.

- 12.2 SAMPLE IDENTIFICATION: Each sample shall be contained in a clean container, which shall be securely fastened to prevent loss of material. It shall be tagged for

identification. The tag shall contain the following information: (1) Contract No., (2) Sample No., (3) Quantity, (4) Date Sample was taken, (5) Sampler, and (6) Intended Use.

12.3 CONCRETE TESTING:

- a. Testing consistency of concrete slump shall be determined in accordance with ASTM C143. Samples for a slump determination will be taken from the concrete during placing in the forms. Tests shall be made.
- b. Tests shall likewise be made at the beginning of a concrete placement operation and at subsequent intervals to ensure that the specification requirements are met.
- c. Concrete testing shall also be done whenever test cylinders are made.
- d. Testing of specimens for compressive strength shall be in accordance with ASTM C39. Test will be made at 7 and 28 days from time of molding. When a satisfactory relationship between 7- and 28-day strengths has been established, the 7-day tests' results may be used as an indicator of the 28-day strength. Each test shall be the average of the strengths of the three test specimens of a set except that if one specimen in a set of three shows evidence, other than low strength, or improper sampling, molding, handling, or curing, the remaining two specimens shall be considered the test result. No more than 10 percent of the cylinders tested shall have compressive strengths less than that specified.

- 12.4 CONTRACTOR-FURNISHED MIX DESIGN: If test results of any concrete to be used in the project show that the concrete strength is below the specified limits and does not meet other requirements of this specification, the contractor shall make all necessary adjustments, as directed by the Construction Architect/Engineer at the Contractor's expense. Concrete, which, at the end of 28 days, does not meet the specified strength, shall be removed or otherwise corrected at the Contractor's expense, with corrective methods subject to the approval of the Construction Architect/Engineer.

-----END OF SECTION-----

DIVISION 4.0 METAL

SECTION 4.01 GENERAL CONDITIONS

PART 1.0 GENERAL

- 1.1 **DESCRIPTION:** The contents of this section apply to all sections of this division unless otherwise specified or modified.
- 1.2 **REFERENCE STANDARDS:** Comply with the latest edition of the following of the following as applicable unless otherwise specified or modified:
- A. **AMERICAN INSTITUTE OF STEEL CONSTRUCTION (AISC), 1978:** Specification for the Design, Fabrication and Erection of Structural Steel for Building; Code of Standard Practice for Steel Buildings and Bridges: Specification for Architecturally Exposed Structural Steel.
 - B. **AMERICAN IRON AND STEEL INSTITUTE (AISI):** "Specifications for the Design of Cold Formed Steel Structural Members, 1974.'
 - C. **AMERICAN WELDING SOCIETY (AWS):** Standard Welding Symbols A2.0-68; Standard Welding Code DI.1-1973 (Rev. 1-73 & 2-74). (To govern if in conflict with AISC).
 - D. **RESEARCH COUNCIL ON RIVETED AND BOLTED JOINTS OF THE ENGINEERING FOUNDATION (RCRBJ):** Specification for Structural Joists using ASTM A-325-76a Bolts.
 - E. **STEEL JOIST INSTITUTE-AMERICAN INSTITUTE OF STEEL CONSTRUCTION (SJI-AISC):** 'Standard Specifications for Open Web Steel Joists,' and 'Standard Specifications for Long span Steel Joists,' 1978 Editions.
 - F. **STRUCTURAL STEEL PAINTING COUNCIL (SSPC):** Painting Manual, Volume 1; Good Painting Practice, Painting Manual, Volume 2; Systems and Specifications.
- 1.3 **SOURCE QUALITY CONTROL:** The Contractor shall be responsible for the fabrication, correct fitting and alignment of the various metal items or component members. However, the Fabricator shall permit the Architect or an independent inspection agency, if engaged by the Owner, to inspect work in progress in his shop. Such Inspection shall not relieve the Contractor of his responsibility to furnish materials and workmanship in accordance with the Contract Documents.
- 1.4 **PRODUCT DELIVERY, HANDLING AND STORAGE:** All materials shall be handled and stored in such manner as to prevent damage or disfigurement. Finished items or components shall be stored above ground on platforms, pallets, or other supports and protected from harmful elements.
- 1.5 **PROTECTION:** The installer shall protect any existing work subject to damage during the installation of specified work and shall adequately protect specified work during installation. The installer shall protect finished work that is readily subject to damage by subsequent work or environmental conditions immediately following the installation thereof.
- 1.6 **FIELD MEASUREMENTS:** Fabricator shall take actual measurements in field to verify or supplement dimensions indicated. He shall be responsible for accurate fit of specified work.

- 1.7 FIELD QUALITY CONTROL: Facilities shall be provided by the Contractor, as needed, for the proper inspection of the specified work, including temporary platforms, hoists, protective devices, electric current, etc. Improper workmanship, as determined by the Architect, shall be corrected, and replaced, at no additional cost to the Owner,
- 1.8 CONDITIONS OF WORK-IN-PLACE: Work-in-place, on which specified work is in any way dependent, must be examined. Any defect that may influence satisfactory completion and performance of specified work must be reported, in writing, to the Contractor and the Architect. The absence of such notification shall be construed as acceptance of work-in-place.
- 1.9 CORROSION PROTECTION: Separate dissimilar metals, and metals from soil and other corrosive surfaces, with a 30-mil coating of Bituminous compound, SSPC Paint 12, unless permanent separation is provided.

-----END OF SECTION-----

SECTION 4.02 METAL MATERIALS AND METHODS

PART 1.0 GENERAL

- 1.1 WORK INCLUDED: The contents of this section are Inclusive of all metals used for this project with their corresponding methods of fabrication and Installation.
- 1.2 REFERENCE STANDARD: Refer to Section 3.01- Metals: General Conditions.

PART 2.0 PRODUCTS

- 2.1 MATERIALS:
- A. CAST IRON: Lowest grade acceptable for cast Iron shall be that of BS 321) Grade C. The casting shall be sharp and of exact form and required shape to fit the parts truly and to hold full dimensions. The product must be free from air holes, scratches, core nails, flaws and defects of any kind.
 - B. WROUGHT IRON: Shall be kept free from any crack, blister, flaw and any defect and comply with BS 51, Grade A.
 - C. COPPER: Shall conform to BS 743 and shall not be used in contact with aluminum.
 - D. BRONZE: Shall consist of 56.5% copper, 41.25% zinc) 2.25% lead and shall have a natural polished finish.
 - E. BRASS: Shall conform to any of the three main groups:
 - Alpha brass 0-39 % zinc
 - Alpha plus beta brass 39-46%
 - Beta brass 46-50%
 - F. STAINLESS STEEL SHEET: Shall be of high chromium, high nickel steel. It shall comply generally with the requirements of BS 970 EN and be the type established for welding (58B).

- G. ALUMINUM SECTIONS OF FITTINGS: Shall be anodized of a minimum thickness 0.02mm of natural color or of analok finish as specified. All screws shall be stainless steel or approved alloy, countersunk flush whenever possible.
- H. STEEL: Shall be cold rolled of high tensile strength with good surface finish. Provide tubular steel rafters for all structures. Refer to Structural Plans.
- J. METAL DOOR JAMBS: Shall be of pressed bend prefabricated type, gauge 16, shop painted with metal primer upon delivery to site. Refer to schedule for locations.
- K. GALVANIZED STEEL: Shall be entirely and evenly coated with zinc and free from stains, bare spots and other defects, such as blisters, pits, un-plated areas, cloudy patches, cracks and stains.

PART 3.0 EXECUTION

3.1 INSTALLATION OF FITTINGS AND FIXTURES

- A. Floor gratings shall be provided for trench drains where needed or as indicated in the Plans. Stainless steel shall be used for trench drains located at lab and kitchen areas. Steel floor gratings shall be used for car parks, workshop / automotive areas and where Indicated in the plans. A 25mm recessed space shall be provided at each side of trench drain. Refer to Plans for the length of trench drains.
- B. Material dividers shall be provided at juncture of differences in flooring material, unless otherwise specified. Brass dividers, stainless steel strips, aluminum reducers shall be used, or as indicated In Interior Plans.

-----END OF SECTION-----

SECTION 4.03 STRUCTURAL STEEL WORK

PART 1.0 GENERAL

- 1.1 SCOPE: This section includes structural steel work, complete.
- 1.2 HANDLING, SHIPPING AND STORING OF MATERIALS. All materials shall be handled, shipped, and stored in a manner that will prevent distortion or other damage. Materials shall be stored in a clean location and keep properly drained. All damaged materials shall be replaced or repaired by and at the expense of the contractor.

PART 2.0 MATERIALS

- 2.1 STRUCTURAL CARBON STEEL FOR BOLTED OR WELDED WORK: shall conform to ASTM A36.
- 2.2 STRUCTURAL TUBING FOR BOLTED OR WELDED WORK: shall conform to ASTM A500 or A501.

- 2.3 BOLTS AND NUTS: shall conform to the requirements for regular hexagon bolts and nuts of ANSI 818.2.1 and 818.2.2. Materials shall conform to ASTM 307.
- 2.4 WASHERS: Circular washers shall be flat and smooth and shall conform to requirements for Type A washers in ANSI B 27.2. Beveled washers to American Standard Beams and channel shall be square or rectangular, shall conform tapered in thickness, and shall be smoothed. Washer for use- with high strength bolts shall be hardened.
- 2.5 WELDING ELECTRODES AND RODS
- A. SUBMERGED ARC WELDING. Bare electrodes and flux for submerged arc welding shall conform to the requirements of AWS D1.0, and the following grades:

STEEL	GRADE
A36	SAW-1 or SAW-2

PART 3.0 FABRICATION

- 3.1 GENERAL: Except as modified herein, fabrication shall be in accordance with the applicable specifications and standards of the American Institute of Steel Construction. Workmanship shall be equal to standard commercial practice in modern structural shops. Portions of the work exposed to view shall be finished neatly. Structural materials, either plain or fabricated, shall be stored above the ground on platforms, skits, or other supports. Material shall be kept from dirt, grease, and other foreign matter, and shall be protected as far as practicable from corrosion. All materials shall be clean and straight. If straightening or flattening is necessary, it shall be done by a process and in a manner that will not damage the material. Shearing, flame- cutting and chipping shall be done carefully and accurately. The radii of a re-entrant gas-cut fillet shall be not less than 25 mm and as large as practicable. The top and bottom surfaces of base plates, cap plates of columns and sole plates shall be planed, or the plates shall be hot straightened and parts of members in contact with them shall be faces.
- 3.2 BOLTED CONSTRUCTION: Holes for bolted construction shall be 1.59 mm larger than the nominal diameter of the bolt. Holes shall be clean cut without torn or ragged edges. Outside burrs resulting from reaming or drilling shall be removed. For punched holes the diameter of the die shall not exceed the diameter of the punch by more than 1.59 mm. The dies for sub-punched holes shall be at least 1.59 mm smaller than the nominal diameter of the bolt. If any hole must be enlarged to admit the bolts, they shall be reamed. Reamed holes shall be cylindrical and perpendicular to the member. Where practicable, reamers shall be directed by mechanical means. After assembly of the member and before reaming, holes punched full size and holes sub-punched shall admit a cylindrical pin 3 mm less in diameter than the nominal size of the holes perpendicular to the face of the member without drifting in not less than 75 percent of any group of continuous holes in the same plane. When holes are reamed or drilled, 85 percent of the holes in any contiguous group, after reaming or drilling, shall show no offset greater than 79 mm between adjacent thickness of metal. Bolts' holes shall be at right angle to the member. The slope of bolted parts in contact with the bolt head shall not exceed 1:20 with respect to a plane normal to the bolt axis. Where the surface of a bolted path

has slope of more than 1:20, beveled washer shall be used to compensate for the lack of parallelism.

- 3.3 STRUCTURE'S SUBJECT TO STATIC LOADING: Holes for bolts shall be drilled or sub-punched and reamed, except that where the thickness of the material is not greater than the nominal diameter of the bolt plus 3 mm, the holes may be punched full size.
- 3.4 COMMON BOLTS: Bolts transmitting shear shall be threaded to such a length that not more than one thread would be within the grip of the metal. The bolts shall be of such length that they will extend entirely through the nuts with the beveled end outside the nut. Bolt heads and nuts shall be drawn tight against the work with a suitable wrench not less than 38-cm long. Bolt heads shall be tapped with a hammer while the nut is being tightened.
- 3.5 SHOP PAINTING: All structural steel work, except zinc coated surfaces and steelwork to be embedded in concrete or mortar, shall be shop painted. Surfaces to be welded shall not be coated within 75 mm of the weld, prior to welding. Surfaces shall be thoroughly dry and clean when the paint is applied. No painting shall be done in wet weather except under cover; the temperature shall be above 45 degrees F. but not over 90 degrees F. Paint shall be applied thoroughly. Surfaces that will be concealed or inaccessible after assembly shall be painted prior to assembly.

PART 4.0 PREPARATIONS PRIOR TO ERECTION

- 4.1 CLEANING: Except as modified herein, surfaces shall be cleaned to bare metal by a suitable blasting process. Surfaces that may be damaged by blasting shall be cleaned to bare metal by powered wire brushing or other mechanical means. Surface that will be enclosed from the weather and subject to exposure no more corrosive than an indoor atmosphere controlled for human comfort, may be cleaned by wire brushing or other manual or mechanical means for removal of loose mill scale, rust, dirt, and other deleterious substances. Cleaned surfaces, which become contaminated with rust, dirt, oil, grease, or other contaminants, shall be washed with solvents until thoroughly clean. Steel to be embedded in concrete shall be free from dirt and grease. Bearing surfaces, including contact surfaces within friction-type joints, shall not be painted nor galvanized but shall be coated with rust preventive coating, applied in the shop. The coating shall be removed just prior to field erection using a remover approved by the rust preventive manufacturer. The surfaces, when assembled, shall be free from rust, greases. Dirt and other foreign matter.
- 4.2 PRE-TREATMENT: Except as modified herein, immediately after cleaning, surfaces shall be coated with a coat of pre-treatment coating applied to a dry film thickness of 0.3 to 0.5 mil or be given a crystalline phosphate base coating. The phosphate base coating shall be applied only to blast-cleaned bare metal surfaces.
- 4.3 PRIMING: Treated surfaces shall be primed as soon as practicable after the pre-treatment coating has dried. Except as modified herein, the primer shall be two coats of epoxy type or as specified in Section: Field Painting applied to a minimum dry film thickness of 3 mils. Surfaces that will be concealed after construction and will require no over-painting may be primed. Damage to primed surfaces shall be repaired with primer.

- 4.4 MATCH MARKING: Members and component part of structures shall be assembled, and match marked prior to erection to ensure accurate assembly and adjustment of position on final erection. Painted assembly markings shall be removed from any surface to be welded or riveted. Scratch or notch marks shall be located in a manner that will not affect the strength of the member or cause concentrations of stress.

PART 5.0 ERECTION

- 5.1 GENERAL: Except as modified herein, erection shall be in accordance with the applicable specifications and standards of the AISC "Manual of Steel Construction". Erecting equipment shall be suitable for the work and shall be in first class condition. Where parts cannot be assembled or fitted properly because of errors in fabrication or of deformation due to handling or transportation, such condition shall be reported immediately to the Construction Architect/Engineer and his approval of the method correction obtained. The correction shall be made in his presence. Bent or damaged parts shall be rejected. Steelwork shall be drained properly. Pockets in structures exposed to the weather shall be filled with waterproof material. Safety belts and lines shall be used by workers on high structures, unless safe working platforms or safety nets are provided.
- 5.2 ASSEMBLY: The frame of steel structures shall be carried up true as shown and all match markings shall be followed. Temporary bracing shall be used wherever necessary to support all loads to which the structure may be subjected, including equipment and operation thereof and piles of materials. Such bracing shall be left in a place as long as may be required for safety. The various members forming parts of a completed frame after being assembled shall be aligned and adjusted accurately before being fastened. Fastening of splices of compression members shall be done after the abutting surfaces have been brought completely into contact. No riveting, welding, or bolting shall be done until much of the structure will be stiffened and by has been aligned properly. Bearing surfaces and surfaces which will be in permanent contact shall be cleaned before the members are assembled. As erection progresses, the work shall be bolted or welded sufficiently to take care of all dead load, wind, and erection stresses. Splices will be permitted only where indicated. Erection bolts used in welded construction may be tightened securely and left in place; if removed, the holes shall be filled with plug welds.
- 5.3 FIELD BOLTING: shall be in accordance with the requirements specified for shop fabrication. Unfair holes shall be corrected by reaming.
- 5.4 FIELD WELDING: shall be as specified for shop fabrication of welded construction. Any shop paint on surfaces adjacent to joints to be field-welded shall be wire-brushed to reduce the paint film to a minimum.
- 5.5 FIELD PAINTING: All exposed surface of steelwork shall be shop painted. Surfaces where the shop coat of paint has been damaged shall be retouched using the same system as the original shop painting. Surfaces which will be in contact after erection, except when in contact with bolted or welded connections, shall be given one finish coat before erection. The cleaning, pre-treatment and priming of welds and the areas

adjacent thereto shall be done promptly after the acceptance of the weld and shall be as specified under the shop painting.

PART 6.0 INSPECTION

- 6.1 GENERAL: Contractor's inspection shall be made promptly to permit immediate correction of defects. The inspector shall stamp each piece, which is accepted, with the mark assigned to him. The contractor shall be fully responsible for the accuracy and character of the work in all details, errors or faults which are discovered after delivery or during erection shall be corrected by the contractor in accordance with the requirements of the contract and without increase in the contract price. The contractor shall provide competent supervision and visual inspection of all fabrication through shop inspectors whose primary duty is inspection.

-----END OF SECTION-----

DIVISION 5.0 FINISHES

SECTION 5.01 CONCRETE FINISH

PART 1.0 GENERAL

- 1.1 **WORK INCLUDED:** This section includes the materials and procedures required to achieve finishes on concrete surfaces as stated in the schedule.

PART 2.0 PRODUCTS

2.1 SUBSTRATE MATERIAL

- A. **COMPRESSIVE STRENGTH:** Concrete floor slabs subject to live loads shall have a concrete screed with a maximum thickness of 2" (50mm) and a minimum compressive strength of 1500psi (10MPa).

2.2 FORMS

- A. **PLYWOOD:** For Form Finish.
B. **PHENOLIC FILM FACED PLYWOOD:** 9-18mm thick, laminated-faced ply. Use this on areas designated as having Fair-Faced Concrete Finish.

2.3 SCHEDULE OF FINISHES

- A. **FORM FINISH:** Use plywood form for ceilings designated as unpainted.
B. **FAIR-FACED CONCRETE FINISH:** Use phenolic film-faced plywood for ceiling designated as unpainted. Plywood may be used up to 40 times.
C. **STEEL TROWELLED FINISH:** For floors intended as walking surfaces where indicated in Schedule or for reception of floor coverings.
D. **SMOOTH FINISH CEMENT PLASTER:** For smooth trowelled finish ceiling to receive painted ceiling finishes, provide a thin cement paste after plastering to achieve a smooth finish. Also to receive cement-sand screeding of tiles, marbles, wood flooring and the like.
E. **PLAIN CEMENT FINISH:** Plain cement finish shall be floated to a compact and smooth surface. The top surfaces shall then be steel trowelled to an even, hard surface, free from low and high spots.
F. **HARDENED CONCRETE FLOORS:** Use non-metallic aggregate anti-dust floor hardeners.

2.4 FINISH TOLERANCES: See individual finish specifications for applicable type class.

- A. Class A tolerances shall be true planes within 1/8-inch in 10ft as determined by a 10-foot straightedge placed anywhere on the slab in any direction.
B. Class B tolerances shall be true planes within 1/4-inch in 10ft as determined by a 10-foot straightedge placed anywhere on the slab in any direction.
C. Class C tolerances shall be true planes within 1/4-inch in 2ft as determined by a 2-foot straightedge placed anywhere on the slab in any direction.

PART 3.0 EXECUTION

- 3.1 **AS-CAST PLYWOOD FINISH (Form Finish and Fair-Faced Concrete Finish)**
Concrete shall be cast against forms constructed of plywood not less than 16mm (5/8")

thick or of boards lined with tempered hardboard not less than 5mm (3/16") thick. The arrangement of plywood sheets or liner sheets shall be orderly and symmetrical, and sheets shall be in as large sizes as are practicable. Sheets showing torn grain, worn edges, patches or holes from previous use or other defects which will impair the texture of concrete surfaces shall not be used. All fins on the surface shall be completely removed.

- 3.2 FLOATED FINISH FOR FLATWORK: After the concrete has been placed, struck off, consolidated, and leveled, the concrete shall not be worked further until ready for floating. Floating shall begin when the water sheen has disappeared, and/or when the mix has stiffened sufficiently to permit the proper operation of a power-driven float. The surface shall then be consolidated with power driven floats. Hand floating with wood or cork-faced floats shall be used in locations inaccessible to the power-driven machine. Trueness of surface shall be checked at this stage with a 10-foot straightedge applied at not less than two (2) different angles. All high spots shall be cut down and all low spots filled during this procedure to a Class B tolerance. The slabs shall then be refloated immediately to a uniform, smooth, granular texture.
- 3.3 TROWELED FINISH FOR FLATWORK
- A. Where a troweled finish is specified, the surface shall be finished first with power floats, as specified above where applicable, then with power trowels, and finally with hand trowels.
 - B. The first troweling after power floating shall be done by a power trowel and shall produce a smooth surface which is relatively free of defects which may still contain some trowel marks. Additional troweling shall be done by hand after the surface has hardened sufficiently. The final troweling shall be done when a ringing sound is produced as the trowel is moved over the surface.
 - C. The surface shall be thoroughly consolidated by the troweling operations. The finished surface shall be free of any trowel marks, uniform in texture and appearance, and shall be planed to a Class A tolerance.
 - D. On surfaces intended to support floor coverings, any defects of sufficient magnitude to show through the floor covering shall be removed by grinding.
 - E. All edges and tooled joints shall be finished with a 3mm (1/8") radius tool.
- 3.4 SMOOTH RUBBED FINISH
- A. Smooth rubbed finish shall be produced on freshly hardened concrete. All necessary patching shall have been done immediately after forms have been removed and rubbing shall be completed not later than the following day. Surfaces shall be wetted and rubbed with carborundum brick or other abrasive until a uniform color and texture is produced. No cement grout or slush shall be used other than the cement paste drawn from the "green" concrete itself by rubbing process.
 - B. Rubbing procedure shall be approved by the Architect before starting the work.

-----END OF SECTION-----

SECTION 5.02 TILE FINISH

PART 1.0 GENERAL

- 1.1 **WORK INCLUDED:** This section includes the materials and procedures required material to achieve Tile-surfaces as stated in the schedule.

PART 2.0 PRODUCTS

- 2.1 **SUBSTRATE MATERIAL:** As mentioned in this Section (Finishes – Concrete Finish) 5.01.2.3-E (Smooth Finish as Screeding).

2.2 SCHEDULE OF FINISHES

- A. **INDOOR FLOOR TILE FINISH:** Where area is a common room, free from moist, unless specified in Plans - Glazed Ceramic Tile shall be used.
- B. **OUTDOOR TILE FINISH:** Where the are can be subjected to dampness due to moisture and/or weather conditions, unless specified in Plans – Unglazed Ceramic Tile Shall be used.
- C. **COMFORT ROOM FLOOR TILE FINISH:** Unless otherwise specified by plan, the floor tile shall be Non-Skid Ceramic Tile.
- D. **COMFORT ROOM WALL TILE FINISH:** The material specification shall be similar to indoor floor tiles, preferably Glazed Ceramic Tiles; while dimensions similar to Comfort Room Tiles. It should be at least 1.2m high from the Floor Finish Line, but not more than 2.1m, rest should be painted finish as mentioned in this Section (Finishes – Painting).
- E. **TILE EDGES AND NOSING:** The schedules where tile finish terminates shall be as follows:
 - 1. Where edges are adjacent to different finish such as concrete, asphalt, or tiles of different type and sizes (e.g. 0.3m tile finish to 0.4 tile finish) with no changes in elevation, an Aluminum Tile Mold be installed subject to Architects approval.
 - 2. Where edges are adjacent to different finish such as concrete, asphalt, or tiles of different type and sizes (e.g. 0.3m tile finish to 0.4 tile finish) with minimal changes (<100mm) in elevation or depth, a PVC Tile Strip should be installed subject to Architects approval.
 - 3. Where edges are adjacent to surfaces with greater than 100mm elevation change such as stairs, patio or any accessible areas, an Aluminum Tile/Stair Nosing or any approved equivalent shall be used subject to Architects Approval.

2.3 SUBMITTALS:

- A. **SAMPLES:** Submit representative samples of all materials of to be used for tiles before installation.
- B. **CHECKING:** Before installation- all tile work alignment should be inspected by Architect and Engineer. After installation- flatness and soundness should be checked before acceptance.

2.4 SCHEDULE OF FINISHES

- A. **GLAZED CERAMIC TILES**
 - 1. Material: Gloss Ceramic Tile
 - 2. Size: 400mm x 400mm x 6mm (unless specified in plans)
 - 3. Design: Plain or Patterned (subject to Architects approval)

4. General Color: White / Light
 5. Spacers: >3mm, Maximum of 6mm
 6. Tile Grout: Dark Color (Gray, Dark Brown, or Dark Beige)
- B. UNGLAZED CERAMIC TILES
1. Material: Matte Ceramic Tile
 2. Size: 400mm x 400mm x 6mm (unless specified in plans)
 3. Design: Plain (subject to Architects approval)
 4. General Color: White / Light
 5. Spacers: >3mm, Maximum of 6mm
 6. Tile Grout: Dark Color (Gray, Dark Brown, or Dark Beige)
- C. NON-SKID CERAMIC TILES
1. Material: Matte Ceramic Tile
 2. Size: 300mm x 300mm x 6mm (unless specified in plans)
 3. Design: Textured (subject to Architects approval)
 4. General Color: White / Light
 5. Spacers: >3mm, Maximum of 6mm
 6. Tile Grout: Dark Color (Gray, Dark Brown, or Dark Beige)

PART 3.0 EXECUTION

- 3.1 ALIGNMENT: Unless there are existing tiles adjacent to the area, all line dowry or alignment lines should be centered to the main entrance opening. Make sure the surface must be as follows:

Substrate	Surface Preparation
New Concrete	Concrete must have fully cured (28 days)
Waterproofed Concrete	Cementous waterproofing cured 3 days or after leak test
Painted Concrete	Abrade Paint (w/ steel brush and paint remover)
Smooth Concrete	Apply scratches to roughen
Repair Works	Remove old lose tile & concrete mortar

- 3.2 TILE ADHESIVE: Use of a Heavy-Duty tile Adhesive, must be greater than 2 N/mm² (2 MPa) adhesion strength. The tile adhesive must be mechanically mixed with recommended amount of water to achieve best consistency. Apply a Medium Bed on tiles and the surface (total of 6mm on both surface and tile backing). Using a notched trowel, spread the tile adhesive in one direction only, avoid applying in omnidirectional or curved motion. Install the tiles and lightly tap with a rubber mallet.
- 3.3. TILE GROUT: Mix the tile grout with water, or waterproofing if required. Spread the tile grout mortar diagonally using a Squeegee. Apply pressure to fill joints completely. After 5 minutes or when the tile grout is lightly dried, remove haze on tiles using a damp sponge. Let it dry. Polish the remaining residue with a lint-free cloth to reveal the tile color. Avoid foot traffic for at least 24 hours.

-----END OF SECTION-----

SECTION 5.03 CEILING SUSPENSION SYSTEM

PART 1.0 GENERAL

- 1.1 DESCRIPTION:
- A. INCLUDED: All items and components forming any portion of the Suspended Ceiling Subsystem and all work to install same.
 - B. LOCATION: All areas designated in Finish Symbol on Drawings to receive Acoustic Type Ceilings.
- 1.2 QUALIFICATIONS: Refer to Section 5.01 FINISHES.
- 1.3 SUBMITTALS:
- A. SHOP DRAWINGS: Submit copies of ceiling layout indicating the location of all light fixtures, diffusers, etc. Show details of installation, including all special conditions, such as hanger spacing, fastening details, splicing method for main and cross runners, change in levels, and supports at ceiling fixture. Lay out system to permit as large border units as possible.
 - B. SAMPLES: Submit representative samples of all components of each type of ceiling subsystem.
 - C. MAINTENANCE PROGRAM: Submit manufacturers' latest printed recommendations for proper owner maintenance program.
- 1.4 PRODUCT DELIVERY, HANDLING, AND STORAGE: Refer to Section 4.01 FINISHES.
- 1.5 ENVIRONMENTAL CONDITIONS:
- A. Installation of all dampening materials shall be installed prior to the installation of specified work.
 - B. In areas where specified work is to be installed, maintain uniform humidity and temperature for at least twenty- four (24) hours prior to, during, and after installation

PART 2.0 PRODUCTS

- 2.1 LAY - IN ACOUSTIC CEILING TILE SYSTEM (Exposed T- bar system): Acoustic ceiling panel shall consist of the following:
- A. ACOUSTIC CEILING TILES
 - 1. Description: Acoustically efficient, fire-resistant, durable ceiling board faced with vinyl film.
 - 2. Size: 24"x24"x5/8"
 - 3. Design: Perforated or Plain
 - 4. Thermal Resistance: 1.6 (R Value)
 - 5. Noise Reduction Coefficient; 0.50 - 0.60
 - 6. Light Reflectance Value: 70 % -74 %
 - 7. Sound Absorption Coefficient

<u>AS 1045</u>	<u>Frequency (Hz)</u>
0.42	125
0.36	250
0.55	500

0.69	1000
0.56	2000

B. EXPOSED T-BAR CEILING SYSTEM

1. Treatment : All Metal frames shall be hot-dipped galvanized
2. Main T-bar : 32 mm x 24 mm x 0.30 mm thick baked enamel white
3. Cross T- bar : 25 mm x 24 mm x 0.30 mm thick, baked enamel white
4. Hanger wire : 2.0mmdiameter
5. Hold down Clip : 0.30 mm thick
6. Wall Molding :18 mm x 18 mm x 0.40 mm thick, baked enamel white

2.2 FIBERCEMENT BOARD IN LIGHT METAL FURRING SYSTEM: Fiber-cement board ceiling finish shall consist of:

A. FIBERCEMENT BOARD

1. Description: fire-resistant, non-combustible, durable ceiling board faced with resistance to moisture damage, termites, and rotting.
2. Size: At least 3.5mm thick, unless otherwise specified by plan
3. Design: Plain
4. Density: >1200 kg/m³
5. Direct Screw Withdrawal Strength: >1000N

B. LIGHT METAL FURRING ASSEMBLY

1. Treatment : All Metal frames shall be rest resistant surface
2. Frame Hangers : >6mm Threaded Rod with 0.6mm thick Hanger Clip, spaced at least 1m O.C. or when purlin spacing permits.
3. Carrying Frame : >37mm x 5m x 0.4mm thick Carrying Channel spaced same as to frame hangers
4. Frame Clips : 0.4mm Thick W-Clips located for every furring and carrying channel intersect.
5. Furring : 50mm x 5m x 0.4mm thick Double Furring arranged perpendicular to Carrying Channel, spaced at 600mm O.C.
6. Wall Termination : 20mm x 20mm x 0.6mm thick Wall Angles for peripheries where furring cannot be installed.
7. Connections : for all frame-to-frame connections, they must be connected using Frame Hanger Clips (Threaded Rod to Carrying Channel) and W-Clips (Carrying Channel to Double Furring). Cement board to frame connection must be connected using blind rivets or panhead screws spaced properly as to secure the integrity of the ceiling system and well-flushed to the ceiling surface.
8. Joint Fillers : joints of the fiber-cement boards must be filled with elastic joint fillers such as concrete epoxy or similar materials, with mesh-tapes to secure the epoxy during setting, and properly filled and sanded to conceal joint connections when painted.

PART 3.0 EXECUTION

3.1 INSTALLATION

- A. ACOUSTIC CEILING TILES IN T-FRAME SYSTEM:** Suspended acoustic ceiling system shall be installed in exact pattern indicated and detailed on the

drawings, and in strict accordance with manufacturers' latest printed instructions. Hangers shall be spaced so that maximum deflection does not exceed 1/360 of span between same. Ceiling shall be re-leveled as required.

- B. FIBERCEMENT BOARD IN LIGHT METAL FURRING: For exposed concrete ceiling, hangers should be installed using expansion bolts on roofs; for trussed roof with purlins, hangers should be installed using screws attached to purlins such that the distance between each hanger not greater than 1,000mm on-center.

Hangers must have threads able to carry hanger clips to support carrying channels. Carrying channels must be rigid, aligned and uniformly distanced to each other following the hangers' spacing.

Double furring must be spaced to maximum of 600mm on-center, perpendicular to carrying channels' direction. They must be secured using W-clips in every intersection the double furring and carrying channels made.

For every perimeter of the room, wall angle must be installed to support the edge of fiber-cement boards.

Fiber-cement boards can be installed using pan-head screw or blind rivets securely. Then joint fillers with wire-mesh tape is used so as to conceal the presence of the screws, rivets, and joints.

- 3.2 CUTTING AND FITTING: All cutting and fitting of acoustical materials shall be done as required to complete the specified work and to accommodate the work of Other Trades.
- 3.3 REPAIR OF DEFECTIVE WORK: Refer to Part 3.0 of General Conditions (Section 1.0).
- 3.4 CLEANING: Refer to Part 4.0 of General Conditions (Section 1.0).

-----END OF SECTION-----

SECTION 5.04

PAINTING

PART 1.0 GENERAL

- 1.1 DEFINITION OF PAINT: The term "PAINT " as used herein, includes emulsions, enamels, paints, varnishes, sealers, and other coatings, whether used as prime, intermediate, or finish coats.
- 1.2 QUALIFICATIONS: Refer to Part 1.0 of General Conditions (Section 1.0).
- 1.3 QUALITY ASSURANCE:
- A. The Owner reserves the right to subject material samples to test at his expenses. If such material tests do not meet the specified standards, the cost will be charged to the Contractor.
 - B. Number of coats, where specified, is minimum. Contractor shall apply as many as required to meet specifications for solid, uniform appearance. Where film thickness in mils is specified, spot checks will be made to determine compliance with specified thickness.
- 1.4 SUBMITTALS:
- A. Submit 2 samples of each color or finish (including all coats). Where the same color or finish is to be applied over different materials, samples of each shall be submitted on different materials, where practical.
 - B. Sample size shall be a minimum of 150 mm x 150 mm (6" x 6").
- 1.5 PRODUCT DELIVERY, HANDLING, AND STORAGE:
- A. Specified materials shall be delivered to the job site bearing manufacturers' name, brand name, type of paint, analysis showing all important constituents of the paint, color of paint and instructions for thinning.
 - B. Specified item and/or its components shall be handled in such manner as to prevent damage. The same shall be properly protected from harmful elements or damage by other work prior to its incorporation into the Project.
 - C. Store materials in a well-ventilated space designated for the storage and mixing of paint. Materials delivered to the site shall be properly stored as to minimize exposure to extremes of temperature.
- 1.6 PROTECTION:
- A. Paint materials shall be properly protected from damage, providing for adequate storage space. Take all necessary precautions to prevent fire, such as keeping oily rags in U. L. approved metal containers or removing from building at the end of each day's work.
 - B. All work fittings, furniture, etc., are to be suitably protected during execution of the work. Splashes on floors, walls, etc. are to be removed during progress of work and overall, left clean and perfect upon completion.
 - C. No exterior or exposed painting shall be carried out under adverse weather conditions, such as extremes of temperature, during rain, fog, etc., or if there is excessive dust in the air.
 - D. LEAD CONTENT AND WARNING LABELS
 - 1. The material manufacturer shall state the lead content on the label of any paint product container based on metal percentage of total solids.

2. The label of any paint product exceeding 0.5% lead content shall include the following statement: "This paint contains more than 0.55 lead content and shall not be used on surfaces accessible to children."

- 1.7 FIELD QUALITY CONTROL: Refer to Part 3.0 of General Conditions (Section 1.0)
- 1.8 REPAIR OF DEFECTIVE WORK:
 - A. All defective or damaged work shall be restored to initial condition.
 - B. All voids, cracks, nicks, etc., will be repaired with proper patching material and finished flush with surrounding surfaces.
 - C. Marred or damaged shop coats on metal shall be spot primed with appropriate metal primer.
 - D. Defective or damaged items and/or components, which cannot be repaired or restored to initial conditions, shall be removed and replaced to the satisfaction of the Architect at no additional cost to the Owner.
- 1.9 MECHANICAL AND ELECTRICAL ITEMS: Painting Contractor shall be responsible for painting mechanical and electrical items as specified herein. No name plates, rotating shafts, bearing bronze, electrical windings or valve stems shall be painted, nor shall any part furnished in nickel or chrome plated be painted.
- 1.10 CLEANING: Upon completion of the building, the Painting Contractor shall remove all paint spots from all finished work, remove all empty cans and leave the entire premises free from rubbish or other debris caused by his work. He shall remove his equipment from the premises. He shall clean off all glass free from paint spots and smears and shall present the work clean and free from all types of blemishes.

PART 2.0 PRODUCTS

- 1.0 GENERAL
 - A. Materials are specified to establish the standards of grade and quality desired for the work, principal pigments and vehicle types and minimum percentage of solids content by volume.
 - B. The products of any Manufacturers may be submitted for use provided they there are existing technical data sheets (TDS) and material sample to be approved by the Architect.
 - C. Based on the approved material sample, all the preparation should be followed as TDS desires or as quality is ensured.
- 2.2 COLOR, GLOSS AND TEXTURE: refer to Finish Schedule. All work is to be completed without deviation from these unless written approval Is received from the Architect. No extra cost shall be allowed because of the color variety scheduled.

PART 3.0 EXECUTION

- 3.1 GENERAL:
 - A. Work-in-place, on which specified work is to be applied, shall be examined to ensure that conditions are satisfactory for application of specified materials. Any defect, which may influence satisfactory completion of specified work, shall be

report, in writing, to the Architect. Absence of such notification will be construed as acceptance of work-in-place.

- B. Do not apply exterior paint in damp or rainy weather or until surfaces have thoroughly dried from the effects of such weather.
- C. Before start of painting, remove finish hardware, accessories, plates, lighting fixtures, and similar Items, as approved by the Architect, except U.L. Labels on Fire Door and Frames, which must not be removed. Use only workers skilled in the applicable building trade for removal and reinstallation of finished item in-place.
- D. The following items shall be masked or protected with suitable covering:
 - 1. Sealing₁ caulking and glazing compounds (unless otherwise directed by the Architect).
 - 2. Glass.
 - 3. Gauges, thermometers, and other recording devices.
 - 4. Moving parts of machinery and other mechanical equipment - such as: shafts, couplings, valve stems, and the like.
 - 5. Coated decorative sheet metal work.
 - 6. Sprinkler heads and the like.
 - 7. Underwriter Laboratories Labels (U.L. Labels)

3.2 SURFACES PREPARATION AS APPLIED TO VARIOUS SUBSTRATE:

A. WOOD:

New Surface:

- Surface to be painted should be clean and dry, free from oil, grease, dust, dirt, contaminants and all loose girt or mortar; sand rough edges remaining, countersink nail heads for putty applications.
- Dust off surfaces completely then wipe with a clean rag.

Repainting:

- Remove scaling, flaking, blistering, and peeling off paint either with the use of PAINT AND VARNISH REMOVER, wire brushing, scraping, or water blasting. Let dry.
- For glossy areas, sand and dust clean.
- In case of mildew infestation, treat with FUNGICIDAL WASH SOLUTION by swabbing or brushing. To ensure proper treatment, allow either solution to remain in surface for 24 hours. Brush off and rinse with water.

B. METAL:

New Surface:

- Surface to be painted should be clean and dry, free from oil, grease, dust, dirt, wax, solder flux, and other contaminants by wiping with mineral spirits or paint thinner.
- Remove rust by application of Rust-remover/converter, soaked with water then wire brushing, sanding, or scraping.
- Where maximum performance of protective coatings is necessary (e.g. Industrial Plants), prepare surface by blast cleaning.

Repainting:

- Sand wire brush or scrape rusted metals and apply METAL ETCHING SOLUTION to remove rust. Let it stay for 10 to 15 minutes. Be sure to wash off surface thoroughly with mineral spirits, letting it dry before applying paint. Primer should be applied a few hours after application of metal etching solution before rust sets in.

C. CONCRETE:

New Surface:

- Surface to be painted should be clean and dry, free from oil, grease, dust, dirt, contaminants and all loose girt or mortar.
- Treat with CONCRETE NEUTRALIZER. As instructed by the chemical's manual, dilute the concrete neutralizer into water. Apply liberally by brush and let dry overnight.
- Rinse with water to remove white crystals that form on the surface. Let dry.

Repainting:

- For existing skim-coated smooth surface, as deemed necessary by the Architect, apply the priming coat before proceeding to succeeding coats. If not, sand the surface using Grit #80 - #120 Sandpaper before smoothing the surface to remove unnecessary textures.

D. CAULKING:

- Oil-Based caulking compound surfaces to be painted shall be prepared by removing all foreign materials.

3.3 PAINT APPLICATION

- A. GENERAL: Specified work shall be done by skilled painters in sophisticated manner. All spaces shall be broom-cleaned before painting is started. Surface to be painted shall be clean, dry, smooth, and adequately protected from dampness. Each coat of paint shall be allowed to dry at least twenty-four (24) hours before succeeding coat is applied. Finish work shall be uniform, of approved color, smooth and free from runs, sags, defective coverage, clogging or excessive flooding. If surfaces are not adequately covered, as determined by the Architect, further coat shall be applied to the satisfaction of the Architect. Edges of paint adjoining other materials or colors shall be sharp and clean without overlapping.
- B. PAINT MIXING: Paint mixing and thinning shall be done only in accordance with directions of Manufacturer. Paint must be strained free from all skin and extraneous substances and shall be thoroughly mixed in a clean container during use.
- C. METHODS OF APPLICATION: Exterior first coats and Interior first coats shall be applied by brush, except on shop-primed surfaces, which shall be applied by brush or roller. All primer shall be applied by brush. Succeeding coats over field-primed surfaces and all coats over shop-primed surfaces may be applied by brush roller or spray. Distemper brushes are to be of approved type and less than 15 cm in width. Rollers for applying enamel shall have a short nap. Spray equipment shall be as recommended by the manufacturer of the paint used. Areas inaccessible to spray painting shall be coated by brushing or suitable method.
- D. COATING: Consecutive coats of paints are to be slightly differing tints except in the case white. Each coat shall be allowed to harden before the next is applied. Rubbing down between coats is to be done with fine abrasive paper.
- E. WOOD FINISHING: Wood to have natural satin varnish finish shall be stained as required and sealed as soon as such items are delivered to the job site. Seal all ends to exclude moisture. Knotting shall be carried out by using resin paint dissolved in spirit or approved ready mixed compound.
- F. DEFECTS IN MASONRY, CONCRETE, PLASTER AND GYPSUM BOARD: Small cracks, holes, and other similar imperfections in masonry, concrete and plaster surfaces, which show up after the prime-sealer has been applied to the surface, shall be filled with an approved spackling compound or putty before application of succeeding coats.
- G. WOODWORK AND METALWORK: Primed or undercoated woodwork and metalwork shall not be left in an exposed or unsuitable situation for an undue period before completing the painting process. Stopping and filling shall be deemed to be

- included for all metal works, plaster works, and woodwork specified to be used to produce a surface ready for priming and painting.
- H. FINAL TOUCH-UPS: Upon completion, finish work shall be touched-up and restored where damaged and left in good condition.

PART 4.0 PAINTING SCHEDULE

- 4.1 GENERAL: Painting Systems shall be applied to surfaces as scheduled. All walls to be painted shall be plastered prior to painting. All under slabs to be painted shall have fair-faced concrete.
- 4.2 FILM THICKNESSES: As recommended by paint manufacturer for the paint specified, includes thickness in mils and number of coats.
- 4.3 SCHEDULE:
- A. MASONRY AND CONCRETE
1. Interior and Exterior Surfaces
 - Textured Finish (flat, semi – gloss, gloss paint). Treat with concrete neutralizer.
 - Preparation : Skim coat (smooth finished)
 - Primer : Flat Latex White (2 Coats)
 - Putty (filler) : Masonry Putty
 - Top-Coat : Flat (interior walls), Gloss (exterior walls), Flat (ceiling); colors subject to Architect’s Approval
- B. WOOD SURFACES
1. Painted Doors, jambs, cabinets, shelves (Semi - gloss finish, lacquer type spray)
 - Textured Finish (flat, semi – gloss, gloss paint). Treat with concrete neutralizer.
 - 1st Coat : Primer Surfacer
 - 2nd Coat : Lacquer Spot Putty (if required)
 - 3rd Coat : Lacquer Primer Surfacer on puttied areas
 - 4th Coat : Automotive Lacquer Enamel
 2. Plain painted surfaces such as walls & partitions (Semi-gloss finish- Alkyd type)
 - 1st Coat : Flat wall Enamel
 - Putty : Glazing Putty
 - 2nd Coat : Semi-Gloss Enamel
 - 3rd Coat : Semi-Gloss Enamel
- C. METAL SURFACES
1. Gloss Finish (Alkyd Type) for G. I. Pipes, etc.
 - 1st Coat : Metal Primer Zinc Chromate
 - 2nd Coat : Glazing Putty
 - 3rd Coat : Quick Dry Enamel
 2. Gloss Finish (Epoxy type) for metal elements and doors, wrought iron grills, W.I. railing, B.I. and G.I. pipe handrails
 - 1st Coat : Epoxy Primer White
 - 2nd Coat : Epoxy Enamel
 - 3rd Coat : Epoxy Enamel

-----END OF SECTION-----

SECTION 5.05

DOORS AND WINDOWS

PART 1.0 GENERAL

- 1.1 DEFINITION OF DOORS AND WINDOWS: The term "DOORS" as used herein, includes wall openings, provided whether these portions are movable or hollow that provides access to human traffic. The term "WINDOWS" on the other hand, includes any wall openings, regardless of whether they are articulated or fixed, which separates the room using transparent or translucent layer such as glass.
- 1.2 SUBMITTALS:
 - A. Submit 2 samples of framing, or Material Data Sheet of components to be used for the fabrication of such material.
 - B. For glass windows and door, submit material sample at least 50mm x 100mm cut, with tinting applied if required by the Plan.
- 1.3 PRODUCT DELIVERY, HANDLING, AND STORAGE:
 - A. Materials should be free from dents and scratches, applied protection film must not be removed.
 - B. Specified item and/or its components shall be handled in such manner as to prevent damage. The same shall be properly protected from harmful elements or damage by other work prior to its incorporation into the Project.
- 1.4 PROTECTION:
 - A. As to promote environmental safety, use of powder coated aluminum frame must be used as necessary.
 - B. Edges of each materials stored, must be properly protected using foams or cardboards to avoid accidents before installation or fabrication procedure.
- 1.5 REPAIR OF DEFECTIVE WORK:
 - A. All visible dents must be replaced during the construction.
 - B. Glasses damaged, or cracked must not be used and replaced immediately to avoid incurring hazards.
 - C. Tinting materials must not be crimped, for such instances, removal and reapplication of tinting materials must be commenced.
 - D. Moving mechanism such as hinges, rollers, tracks, locks, handles etc., must be smooth, easily handled and free from movement restrictions, otherwise these items will be deemed defective and must be repaired or replaced.
 - E. Chipped paint must be repainted, in cases of Powder coated frames, materials must be replaced.
 - F. Sealants and other caulking materials must be free from damage, and not be easily stripped by hand, in cases where these materials are defective, the whole sealed portion must be removed and re-sealed.
- 1.6 CLEANING: Once unnecessary paints and other materials adhered to the frame and glass/ wood panel, cleaning using thinner or any compounds that were labeled safe for the existing finish of each door and windows must be used. These shall be cleaned with damp cloth otherwise to remove residues of the compound used.

PART 2.0 PRODUCTS

2.1 GENERAL: Materials are specified to establish the standards of grade and quality desired for the framing, supports, articulation and glass/wood/plastic panels used for the work.

2.2 DOORS

A. WOOD PANEL DOOR: Must be made of good lumber. With a Top Rail, Bottom Rail and at least one Lock Rail. These doors must be hinged and opened outwards.

1. Type : Single Leaf Door
2. Articulation : Swing Door (Hinged)
3. Opening : Outwards (Left or Right-Handed as shown in plans)
4. Panels : Good Lumber (>50mm thick) Painted (see Section 5.04 – Painting)
5. Frames : Good Lumber (>50mm thick)
6. Dimensions : (shown in plans)
7. Jamb Type : Good Lumber (>50mm x 100mm through)
8. Handle : Circular doorknob with Lockset

B. GLASS PANEL DOOR: Must be made of glass in aluminum frame. With Top and Bottom Rail frames and push bars. These doors must be hinged and opened outwards.

1. Type : Single Lead Door
2. Articulation : Swing Door (Hinged)
3. Opening : Two-Way Opening
4. Panels : 6mm Thick Glass Panels - Transparent Glass (clear color)
5. Frames : Powder Coated Aluminum Frame (Dark Brown)
6. Dimensions : (shown in plans)
7. Jamb Type : Powder Coated Aluminum Frame w/ Bottom Threshold
8. Handle : Aluminum Push Bar (Horizontal) with Lockset

2.3 WINDOWS: Must be made of glass in aluminum frame

A. AWNING WINDOW

1. Type : Awning
2. Opening : Single Awning Upwards
3. Panels : 6mm Thick Glass Panels (Dark Tint)
4. Frames : Powder Coated Aluminum Frame (Dark Brown)
5. Handles : Die Cast Latch/Lock Handle (Dark Brown)
6. Dimensions : (shown in plans)

B. FIXED WINDOW

1. Type : Fixed
2. Opening : Single Awning Upwards
3. Panels : 6mm Thick Glass Panels - Transparent Glass (clear color)
4. Frames : Powder Coated Aluminum Frame (Dark Brown)
5. Handles : n/a
6. Dimensions : (shown in plans)

-----END OF SECTION-----

DIVISION 6.0 ELECTRICAL

SECTION 6.01 ELECTRICAL WORK

PART 1.0 GENERAL

1.1 **SCOPE / WORK INCLUDED:** Work in this section covers the requirements for a complete electrical installation, including the furnishing of all labor, materials, equipment, tools, transportation, storage, incidentals, and superintendence necessary to accomplish the electrical installation. The work includes, but is not necessarily limited to, the installation of interior lighting and power system. If anything has been omitted in any item of works usually furnished, which are necessary for the completion of electrical works, then such items must be included.

1.2 **QUALITY ASSURANCE:**

- A. **REFERENCE STANDARDS:** Electrical equipment, materials and procedures shall conform to the applicable requirements of the latest edition of the following: Underwriter's Laboratories, (UL), National Fire Protection Association (NFPA), National Electrical Manufacturer's Association (NEMA) and other related publications.
- B. **WORKMANSHIP:** All equipment and materials shall be installed in a neat and workmanlike manner.
- C. **QUALIFICATION OF INSTALLER:** At least one licensed electrician, who has been thoroughly trained and experienced in the skills required, and who is completely familiar with the methods of installation, must be always present during the installation. He shall direct all work performed under this section.

1.3 **COMPLIANCE TO APPLICABLE CODES AND REGULATIONS:** All installation procedures, materials and equipment shall comply with the following as applicable:

- A. Philippine Electrical Code.
- B. National Electrical Safety Code, latest edition.
- C. Power Company Regulations.
- D. National Fire Protection Association
- E. Bureau of Labor Standards.
- F. Local laws and ordinances

1.4 **REPAIRS TO DAMAGED EXISTING WORK:** Any damage to building, piping, or equipment caused by this work shall be repaired by skilled mechanics of the trades involved, at no additional cost to the Owner.

1.5 **SUBMITTAL:** The contractor shall submit for approval one sample of each fixture, wires, and wiring devices. For circuit breakers, boxes and panel boards, catalogs or brochures may be submitted.

1.6 **RECORD DRAWINGS:** The Contractor shall keep a careful record of all the changes made in the actual installation, which differs from that shown on the Contract Drawings. Upon completion, the Contractor shall, in a neat and accurate manner, finalize "AS BUILT" drawings on tracing paper. These drawings shall be submitted to the Construction Architect/Engineer for approval. After approval, they shall become the property of the Owners. The print copies shall be duly signed and sealed by a Licensed Electrical Engineer.

PART 2.0 MATERIALS

- 2.1 LIGHTING FIXTURES AND LAMPS: The Contractor shall provide and install all lighting fixtures of the size and type as indicated on the drawings. All fixtures shall be wired and installed complete, including all lamps and/or tubes, transformers, ballasts, supports, brackets, canopies, globes and other parts and devices necessary for complete installation and operation.
- 2.2 FLUORESCENT FIXTURE UNIT: shall be complete. The tube shall be accessible without removing the fixture. Fixture shall be direct connected to 220 volts system as shown.
- A. Ballast shall be built to the specification adopted by the certified ballasts manufacturers approved by the Electrical Testing Laboratory with lowest sound rating with UL label. Ballasts shall be 220V rapid start high power factor series type "P" (0.95) p.f. capacitive "A" sound rating.
 - B. Fluorescent tubes shall be standard cool white rapid start of wattage and quantity shown.
 - C. Fluorescent fixture housing shall be US gauge 22 sheet steel. Reflecting surfaces shall have baked white; acrylic finish preceded by one coat of baked gray primer. Acrylic shall be color stable and non-aging. Non-reflecting surfaces shall be finished with baked light gray enamel preceded by one coat of dark gray primer.
 - D. Acrylic glasses of the size and configuration shown shall be provided.
- 2.3 WIRES AND CABLES: for lighting, intercom, telephone, televisions, and other requirements shall be of standard sizes as Technical Data Sheet suggests. Sizes and type of wires shall be as indicated and shall pass the stringent quality requirements set by the Ministry of International Trade and Industry of Japan and the Philippine standards.
- A. All wires shall be copper, soft-drawn and annealed, shall be of ninety-eight (98%) conductivity, shall be smooth and true and of a cylindrical form and shall be within one percent (1%) of the actual size called for.
 - B. Wires or cables for lighting and power systems shall be plastic insulated for 600 volt working pressure, type THW unless otherwise noted on plans or specified below. All wires AWG No. 8 and larger shall be stranded copper.
 - C. Control leads for motors or lighting shall be type THW for lighting and power systems. No wire smaller than No. 12 gauge or as indicated shall be used, except for control leads.
- 2.4 CONDUIT: for interior systems shall be uPVC V2000 Rigid Electrical conduits approved by the Architect or Engineer.
- A. No conduit shall be used in any system smaller than ½-inch electric trade sized, nor shall have more than four ninety degrees bends in any one run. If necessary, pull boxes shall be provided as directed.
 - B. No wire shall be pulled into any conduit until the conduit system is complete in all details; in the case of concealed work, until all rough plastering or masonry has been completed; in the case of exposed work, until the conduit has been completed in every detail.

- C. The ends of all conduits shall be tightly plugged to exclude plaster, dust, and moisture while the building is in the process of construction. All conduits shall be reamed to remove all burrs.
- D. All pipes and fittings on exposed work shall be secured by means of metal clips spaced a maximum of five feet which shall be held in place by means of a machine screw. When running over concrete-surfaces, the screws shall be held in place by expansion sleeves. All pipes on exposed work shall run at right angles to and parallel with the surrounding walls and shall conform to the form of the ceiling, no diagonal runs shall be allowed, and all ends and offsets shall be avoided as far as possible. Where necessary, conduit fittings shall be used. Piping, in all cases shall be run perfect straight and true, satisfactory to the Construction Architect/Engineer.

2.5 OUTLET BOXES AND FITTINGS:

- A. All outlets of whatever kind for all systems shall be provided with a suitable fitting which shall be either a box or other device specially designed to receive the type of fittings to be mounted thereon.
- B. The Contractor shall consult the Construction Architect/Engineer as to the nature of the various fittings to be used before installing his outlet fittings, to the nature of appliance to be a finished design.
- C. In the case of fixtures, their outlet fittings shall be provided with suitable fixture supports of a size and kind required by the fixture to be hung. Fixture studs in general shall be 3/8 inch.
- D. All outlets on exposed conduit work shall be cast alloy conduit fittings of proper type, as approved by Architect or Engineer.
- E. At all outlets on concealed conduit work, provide galvanized pressed steel outlet boxes of standard make.

2.6 WALL SWITCHES: Wall switches shall be rated at 15 amperes, 250 volts, one-way, as required. The type of switch shall be tumbler operation and the color, plating and appearance of wall plates shall be submitted prior to the purchase of wall switches and face plates. Switches shall be as approved by the Architect or Engineer.

2.7 JUNCTION AND PULL BOXES: Junction and pull boxes, of code gauge steel, shall be provided for facilitating the pulling of wires and cables. Pull boxes in finished places shall be located installed with the permission and to the satisfaction of the Construction Architect/Engineer.

2.8 WALL RECEPTACLES: Receptacle outlets shall be for flush mounting duplex rated at 15 amp., 250 volts, parallel slots with grounding slot. Type and color of receptacle outlet plates shall be as selected by the Architect and appropriate samples of outlets and plates shall be submitted prior to purchase of devices.

2.9 CIRCUIT BREAKERS: shall consist of a quick-make, quick break type entirely trip-free operating mechanism, with contacts arc interrupter, and thermal-magnetic trip unit for each pole, all enclosed in a molded-phenolic case. The thermal magnetic trip unit shall provide time-delayed overload protection and instantaneous short circuit protection, and in case of overload or short circuit in any one pole. Circuit breaker shall be trip indicating, with the tripped position of breaker handle midway between "ON" and "OFF" positions. Circuit breakers shall be approved by the Architect or Engineer. All circuit breakers rated above 225 amperes shall have interchangeable trip units.

2.10 PANELS AND CABINETS:

- A. Standard panels and cabinets, as far as possible, shall be dead front construction furnished with trims for flush mounting as required. Cabinets shall be code gage steel with gutters at least 4-inch wide and wider if necessary. The trim for all panels shall be finished in gray enamel over a rust inhibitor. Panels and cabinets shall be as approved by Architect or Engineer. Manufacturer's shop drawings in triplicate shall be submitted.
- B. 220- volt lighting panels shall be equipped with 20A circuit breakers in the branch circuits and a three-pole circuit breaker in the main unless noted otherwise on plans. As indicated on plans the panels shall be assembled in two or more selection if over 20 two-pole circuits or 40 one pole circuits. Circuit breakers shall be as approved by the Architect or Engineer.
- C. Distribution panels shall be of same type as lighting panels except equipped with one-pole, two-pole, and three-pole circuit breakers frame up of sizes called for on plans.

2.11 MOTOR STARTERS (if applicable):

- A. Provide proper size, characteristics and HP rating as required by the motor. Use motor nameplate data for selection of overload relays. Provide an overload for each conductor.
- B. Provide an enclosure for all starters. National Electrical Manufacturer's Association (NEMA) - NEMA 1 for general use and the equivalent of NEMA 3R for exterior or wet or damp locations.
- C. Across the line for 7-1/2 HP or less and reduced voltage type for 10 HP and larger.

2.12 GROUNDING AND BONDING EQUIPMENT: Shall be in accordance with Article 250 N. E. C. as amended by the office of the Building Official (DPWH).

2.13 GROUNDING CONDUCTORS: Non-metallic raceways, size per table 250-95 N. E. C.

PART 3.0 LOCATION OF WIRING AND OUTLETS

3.1 It shall be the responsibility of the Contractor to study all pertinent drawings and obtain precise information as to the exact location of all outlets, apparatus, appliances, and wiring to be installed. It shall be understood that any outlet may be relocated on a distance not exceeding 15 feet from the location shown on the drawings. Contractor shall make any necessary adjustment of his work to fit conditions for recessed fixtures and for outlets occurring in glazed tile, block, terra cotta, marble, wood paneling, or other special finish materials in order that all boxes may register flush with finish and shall be centered properly. In centering outlets, due allowance shall be made for overhead piping, ducts, window, and door trim, variations in thickness of plastering, etc., as erected, regardless of conditions which may be otherwise shown on small scale drawings. Outlets incorrectly located shall be properly relocated at the Contractor's expense. Local switches near doors shall be located at the stride side of the door.

3.2 The center of wall outlets, socket-outlets, switches, telephone outlets, pilot lights, indicating lights and clock outlets shall be installed at heights above finished floor as

indicated on the drawings. Where mounting heights are indicated on the Electrical Drawings, they shall be verified with Architect's drawings before installation.

PART 4.0 INSTALLATION

4.1 CONDUIT INSTALLATION:

- A. Conduit installation shall be made with rigid metal conduit and fittings, electrical metallic tubing, or nonmetallic conduit. Electrical metallic tubing shall not be installed underground, encased in concrete, or used in outdoor work. Rigid metal conduit installed underground shall be encased in concrete or covered with a protective coating.
- B. Exposed conduit shall be installed parallel with or at right angles to the building walls and ceilings and shall be supported by pipe straps, wall brackets, hangers, or ceiling trapeze. Fastenings shall be by wood screws on wood; by toggle bolts on hollow masonry units; by concrete inserts, or expansion bolts on concrete or brick; by machine screws, welded threaded studs, or spring tension clamps on steel work. Threaded studs driven in by a powder charge and provided with lock washers and nuts may be used in lieu of expansion bolts or machine or wood screws. Threaded C-clamps may be used on rigid steel conduit only. The load applied to fasteners shall not exceed 1/4 of the proof test load. Fasteners attached to concrete ceilings shall be vibration and shock resistant. Holes cut to a depth of more than 1/2 inches in reinforced concrete beams or to a depth of more than 3/4 inch in concrete joints shall not cut the main reinforcing bars. Holes not used shall be filled. In partitions of light steel construction, sheet-metal screws shall be used. In suspending-ceiling construction, conduit shall be run above the ceiling and only lighting system branch circuit raceways shall be fastened to the ceiling supports. Spring steel fasteners may be used for lighting branch circuit raceway supports in suspended ceilings in dry locations. Conduits shall be fastened to all sheet metal boxes and cabinets with two lock nuts where required by the National Electrical Code, where insulated bushings are used and where bushings cannot be brought into firm contact with the box. Locknuts shall be the type with sharp edges for digging into the wall of metal enclosures. Bushings shall be installed on the ends of all conduits and shall be of the insulating type where required by the National Electrical Code. (Exposed risers in wire shafts of multi-story buildings shall be supported by U-clamp hangers at each floor level and at intervals not to exceed 10 feet. Fittings for steel conduit and electrical metallic tubing shall be iron or steel only.)
- C. Conduit installed in concrete floor slabs shall be located so as not to affect the structural strength of the slabs. Conduit shall be installed within the middle one-third of the concrete slab except where necessary to not disturb the reinforcement. Outside diameter of conduit shall not exceed one-third of the slab thickness and conduits shall be spaced not closer than three diameters except at cabinet locations. Curved portions of bends shall not be visible above the finish slab. Slab thickness shall be increased as necessary to provide a minimum one inch cover over conduit. Where embedded conduits cross expansion joints, suitable watertight expansion fittings and bonding jumpers shall be provided. Conduit larger than one inch trade size shall be parallel with or at right angles to the main reinforcement: when at right angles to the reinforcement, the conduit shall be close to one of the supports of the slab.

- D. Conduits installed in contact with earth shall be rigid steel. Rigid steel conduits shall be encased in concrete. Zinc coating may be omitted from steel conduit, which has a factory-applied epoxy coating. Field made joints, fittings, abrasions, imperfections shall be coated with material equivalent to the above.
- E. Changes in direction or runs shall be made with symmetrical bends or cast-metal fittings. Field made bends and of offset shall be made with a hickey or conduit-bending machine. Crushed or deformed raceways shall not be installed. Trapped raceways in damp or wet locations shall be avoided. Plaster dirt or trash shall be prevented from lodging in raceways, boxes, fittings, and equipment during construction. Clogged raceways shall be freed of all obstructions.

4.2 BOXES, OUTLETS AND SUPPORT:

- A. Boxes shall be in the wiring or raceway systems wherever required for pulling of wires, making connections, and mounting of devices or fixtures. Boxes shall be sheet steel. Each box shall have the volume required by the National Electrical Code for the number of conductors enclosed in the box. Boxes for mounting lighting fixtures shall be not less than 4 inches except that smaller boxes may be installed as required by fixture configuration as approved. Boxes installed for concealed wiring shall be provided with suitable extension rings or plaster covers, as required. Boxes for use in masonry block or tile walls shall be square cornered tile type, or standard boxes having square-cornered tile-type covers. Cast metal boxes installed in wet locations and boxes installed flush with the outside of exterior surfaces shall be gasketed. Separate boxes shall be provided for flush or recessed fixture when required by the fixture terminal operating temperature and fixtures shall be readily removable for access to the boxes unless ceiling access panels are provided. Boxes and pendants for surface-mounted fixtures or suspended ceilings shall be supported independently of the ceiling supports, or adequate provisions shall be made for distributing the load over the ceiling support members in an approved manner. Boxes and supports shall be fastened to wood with wood screws or screw-type nails of equal holding strength, with bolts and expansion shields on concrete or brick, with toggle bolts on hollow masonry units, and with machine screws or welded studs on steel work. Threaded studs driven in by powder charge and provided with lock washers and nuts, or nail-type nylon anchors may be used in lieu of wood screws, expansion shields, or machine screws. In open overhead spaces, cast boxes threaded to raceways need not be separately supported except were used for fixture support; cast metal boxes having threadless connectors and sheet metal boxes shall be supported directly from the building structure or by bar hangers. Where bar hangers are used, the bar shall be attached to raceway, which shall be supported with an approved type of fastener not more than 24 inches from the box. Penetration into reinforced concrete members shall avoid cutting any reinforcing steel.
- B. Pull boxes of not less than the minimum size required by the Philippine Electrical Code shall be constructed of code gage galvanized sheet steel. Boxes shall be furnished with screw-fastened covers. Where several feeders through a common pull box, the feeders shall be tagged to clearly indicate the electrical characteristics, circuit number, and panel designation.
- C. Conduit stubbed up through concrete floors for connections to free standing equipment shall be provided with a short elbow and an adjustable brass tap or coupling brass or bronze threaded inside for plugs, set flush with the finished floor. Wiring shall be extended in rigid threaded conduit to equipment, except that where required, flexible conduit may be used 6 inches above the

floor. Screwdriver-operated threaded flush plugs shall be installed in conduit from which no equipment connections are made.

- 4.3 **DEVICE PLATES OF THE ONE-PIECE TYPE:** shall be provided for all outlets and fittings to suit the devices installed. Plates on unfinished walls and on fittings shall be of zinc-coated sheet or cast metal having rounded or beveled edges. Plates on finished walls shall be of steel with ivory baked-enamel finish. Screws shall be of metal with countersunk heads, in a color to match the finish of the plate. Plate shall be installed with all four edges in continuous contact with finished wall surfaces without the use of mats or similar devices. Plaster filling will not be permitted. Plates shall be installed with an alignment tolerance of 1/6 inch. The use of sectional type device plates will not be permitted. Plates installed in wet locations shall be gasketed. Device plates for telephone and inter-communication outlets shall have a 3/8-inch bushed opening in center.
- 4.4 **RECEPTACLES:** Single and duplex receptacles shall be rated 2-pole, 3-wire grounding type, 15 amperes, 240 volts. Body shall be ivory molded phenolic compound supported on a metal mounting strap. Receptacles shall be side and back wired with screw type terminals. Exposed metal parts shall be corrosion resistant. The ground pole shall be connected to the mounting strap. Special purpose receptacles shall be rated as indicated.
- 4.5 **TOGGLE SWITCHES:** shall be totally enclosed with bodies of molded compound and a mounting strap. Handles shall be ivory. Wiring terminals shall be of the screw type, back or side wired. Switches shall be rated quiet type. AC only, 15 ampere, 250 volt. Switches shall be single poles unless otherwise indicated.
- 4.6 **PANELBOARDS:** Lighting and appliance branch-circuit panelboards shall be circuit equipped, Type I, Class I. Circuit breakers shall be the rating, class painted.
- 4.7 **GROUNDING AND BONDING:** All exposed non-current-carrying metallic parts of electrical equipment, metallic raceway systems, grounding conductor and neutral conductor of wiring systems shall be grounded. The ground connection shall be made at the main service equipment and shall be made to driven rods on the exterior of the building or to the point of entrance of the metallic water service. Connections to flanged pipes shall be made to the street side of the flanged connection. No connections shall be made to water pipes coated with insulating materials.
- 4.8 **RECESSED FLUORESCENT FIXTURES:** Fixtures shall be installed in suspended ceiling opening as indicated. These fixtures shall have adjustable fittings to permit alignment with ceiling panels. Fixtures installed in fire-resistive type of suspended ceiling construction shall be provided with fireproofing boxes having materials of the same fire rating as the ceiling panels, in conformance with the Building Materials List of Underwriter's Laboratories, Inc.
- 4.9 **FLEXIBLE CONNECTIONS:** of the short length shall be provided for equipment subject to vibration, noise transmission, or movement and for all motors. Liquid-tight flexible connections shall be provided as required.
- 4.10 **EQUIPMENT CONNECTIONS:** All wiring for the connection of motors and control equipment shall be furnished and installed under this section of the specification, except

as otherwise specifically noted or specified. Automatic-control wiring, signaling, and protective devices are not included in this section, but shall be furnished and installed under other sections of the specifications. Control wiring not shown on the electrical drawings shall be furnished.

PART 5.0 TESTS

- 5.1 All wiring shall be tested for circuit continuity to assure that the wiring system is free of short circuit, accidental grounding, or other defects prior to normal system operation. Tests shall be performed after all wiring is completed, and again after fixtures and equipment are connected and ready for use.
- 5.2 After the Contractor has assured himself that the wiring systems are free of faults, the Contractor shall then energize the systems from their normal power sources and confirm that all systems are operational as required by the contract documents, prior to final inspection.

-----END OF SECTION-----

DIVISION 7.0 SPECIALTIES

SECTION 7.01 MISCELANEOUS SPECIALTIES

PART 1.0 GENERAL

- 1.1 **SCOPE/WORK INCLUDED:** This section includes specifications on plumbing fixtures, fittings and accessories, selected lighting fixtures, louvers, and others.
- 1.2 **SUBMITTALS:** The Contractor shall furnish, for approval, full Information, and satisfactory evidence as to the kind and quality of materials or articles he will Incorporate in the work.
- 1.3 **QUALIFICATION OF WORKER:** Only competent workmen, who have been thoroughly trained and experienced in the skills required and who are completely familiar with the materials involved and with the requirements of his work, shall be engaged.
- 1.4 **GENERAL REQUIREMENTS:** The project drawings shall show the general requirements as to sizes, arrangement, extent of piping, and location of equipment. Unless otherwise indicated or specified herein, all work shall be accomplished in accordance with the National Plumbing Code.

PART 2.0 PRODUCTS AND MATERIALS

- 2.1 **PIPES AND FITTINGS:**
 - A. **SOIL, WASTE, AND VENT PIPES** shall be uPVC S1000
 1. PVC cement shall be as recommended by the PVC pipe manufacturer, solvent type.
 - B. **VALVES**
 1. Clean-outs shall be provided in all soil, storm, or waste lines at every change in direction greater than 45 degrees, size same as the pipe served. Clean-outs shall be extended to an easily accessible place or where indicated on the drawings.

PART 3.0 INSTALLATION

- 3.1 **GENERAL:** Piping shall be installed according to the shop drawings, as recommended by the manufacturer, and as directed during installation, straight and as direct as possible, forming right angles or parallel lines with building walls and other pipes, and neatly spaced. Erect pipe risers plumb and true, parallel with walls and other pipes neatly spaced. Before being placed in position, pipe and fittings shall be cleaned carefully. All pipes shall be maintained in a clean condition.
- 3.2 **Hangers, or equivalent of approved design.** Supports shall be installed in such a manner to permit pipe free expansion and contraction while minimizing vibration. Do not install pipes in a manner that interferes with other pipes, ducts, conduits, equipment, and adjacent structures of the building. The arrangement, positions and connection of pipes, fixtures, drains, valves, and the like indicated on the drawings shall be followed as closely as possible. All pipes shall be cut accurately to measurement and shall be

worked into place without springing and forcing. Changes in pipes shall be made with reducing fittings. Pipes shall not pass through columns, footings, and beams, except where noted on the drawings.

- 3.3 ROUGH-IN FOR PIPES AND FITTINGS: shall be carried along with the building construction. Correctly located openings of proper sizes shall be provided where required in the walls and floors for the passages of pipes. All items to be embedded in concrete shall be thoroughly cleaned and free from all rust and scale.
- 3.4 PIPES IN TRENCHES: Sewer and water piping shall be placed in separate trenches.
- 3.5 INSTALLATION OF SCREW-JOINTED PIPING: All pipes shall be cut accurately according to measurements established by the contractor and shall be worked into place without springing or forcing. Proper provision shall be made for the expansion and contraction of all pipelines. Pipe and fittings shall be free from fins and burrs. Screw joints shall be made with a lubricant applied on the male threads only; threads shall be full cut and not more than three threads on the pipe shall remain exposed. All exposed ferrous pipe threads after being installed and tested shall be given one coat of zinc chromate and enamel paint.
- 3.6 PROTECTIVE COATING FOR GALVANIZED STEEL PIPING BURIED IN THE GROUND: All galvanized steel piping buried in the ground shall be given a protective coating of zinc chromate primer and enamel paint.

PART 4.0 QUALITY ASSURANCE

- 4.1 TESTS: All defects disclosed by tests shall be rectified and the test repeated. All labor, materials and equipment used for tests shall be provided by the contractor.
 - A. SANITARY PIPING. Before the installation of any fixture, the ends of the system shall be capped, and all lines filled with water to the roof or 3 m above the highest fixture connections if test is done in sections or by floors and allowed to stand for at least 30 minutes without leakage. Test tees having cast iron screwed plugs shall be installed in the vertical stacks when tests are made in sections or by floors. Test within building shall be made with piping exposed. Underground piping shall be tested before backfilling.

PART 5.0 GUARANTEE

The contractor shall furnish to the Owner a written guarantee covering the satisfactory operations of the plumbing installation. This shall be for a period of one year after the date of acceptance. During this period, the contractor shall repair or replace any defective work and pay for any repair or replacement cost. All damages due to improper use or caused by the Owner or his representatives/employees shall be at the Owner's expense.

-----END OF SECTION-----

No materials to be installed without being inspected and approved by any of the engineers/architect and inspectorate team. All work to be undertaken must conform proper standards and specifications.

NOTE:

Site Visit/Inspection is a pre-requisite and must be submitted together with the bidding documents. Non-site inspection will be a ground for disqualification.

Note: Bidders must state either **“Comply”** or **“Not Comply”** or any equivalent term in the column **“Statement of Compliance”** against each of the individual parameters of each **“Specification”**.

I hereby commit to comply with all the above requirements.

Name of Company/Bidder

Bidder’s Signature over Printed Name

Date: _____

Section VII. Drawings



PERSPECTIVE
DRMD CONTROL CENTER





PERSPECTIVE
ROS OFFICE





PERSPECTIVE
DRMD CONTROL CENTER



NOTE: FURNITURE & EQUIPMENT EXCLUDED

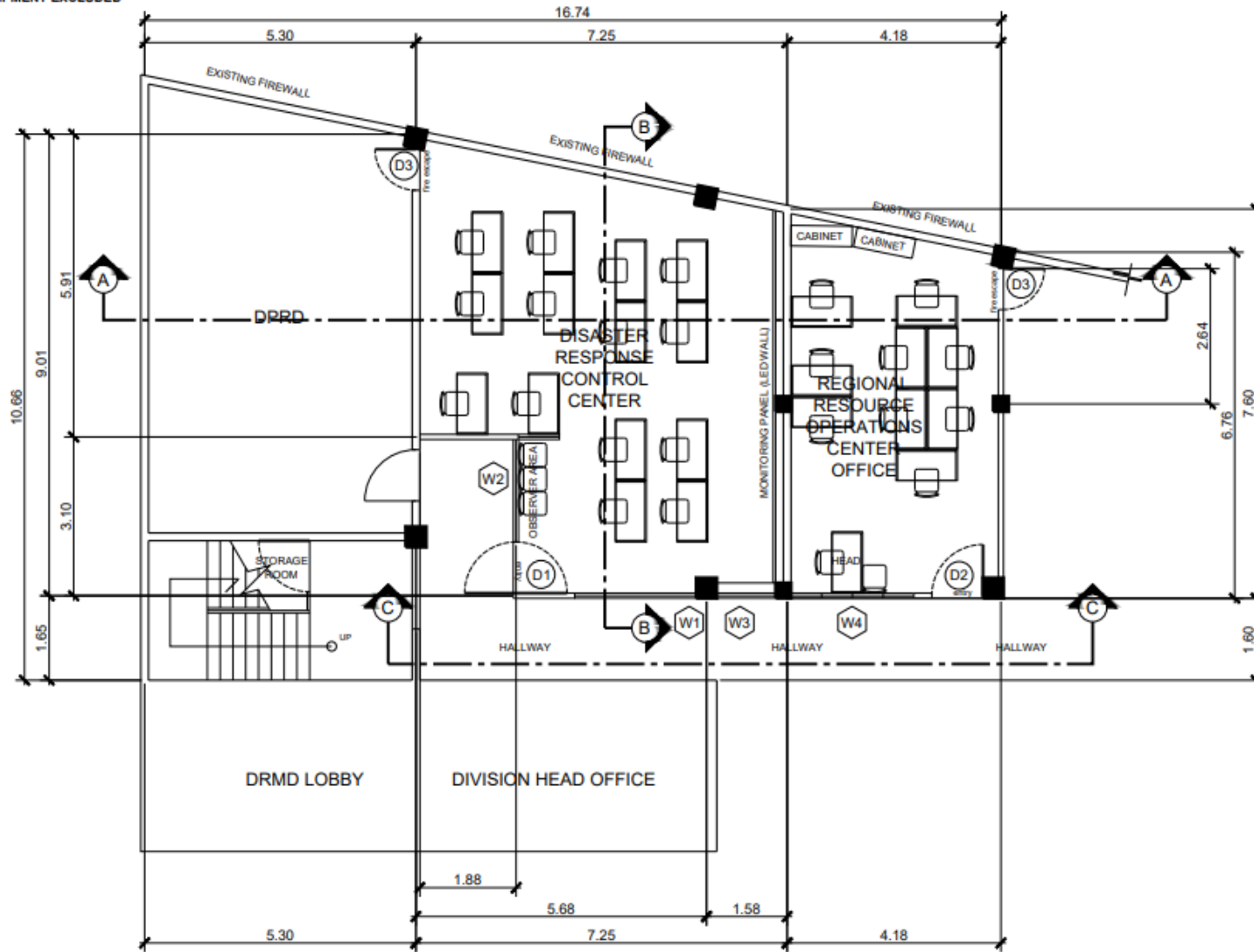

FLOOR PLAN

SCALE// NOT TO SCALE

NOTE: FURNITURE & EQUIPMENT EXCLUDED

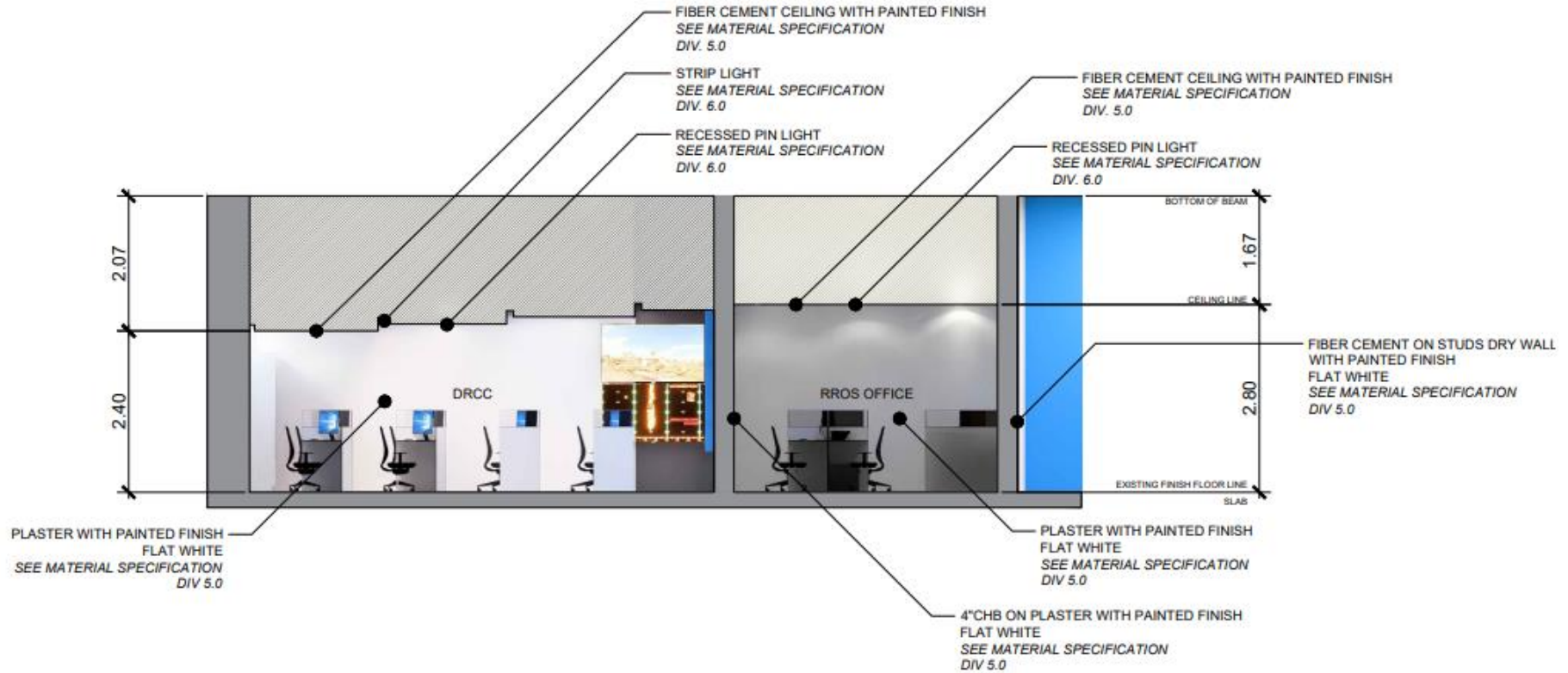

LONGITUDINAL SECTION THRU A-A

SCALE: NOT TO SCALE

NOTE: FURNITURE & EQUIPMENT EXCLUDED

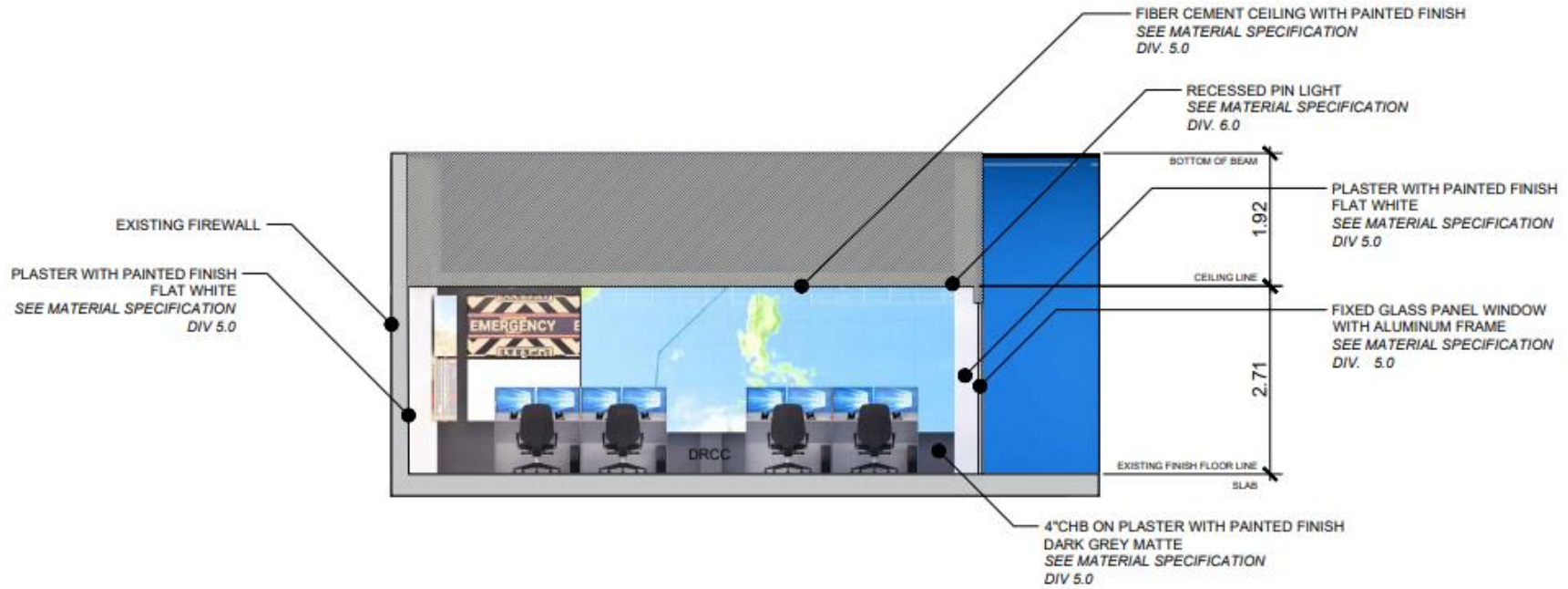

CROSS SECTION THRU B-B

SCALE: NOT TO SCALE

NOTE: FURNITURE & EQUIPMENT EXCLUDED

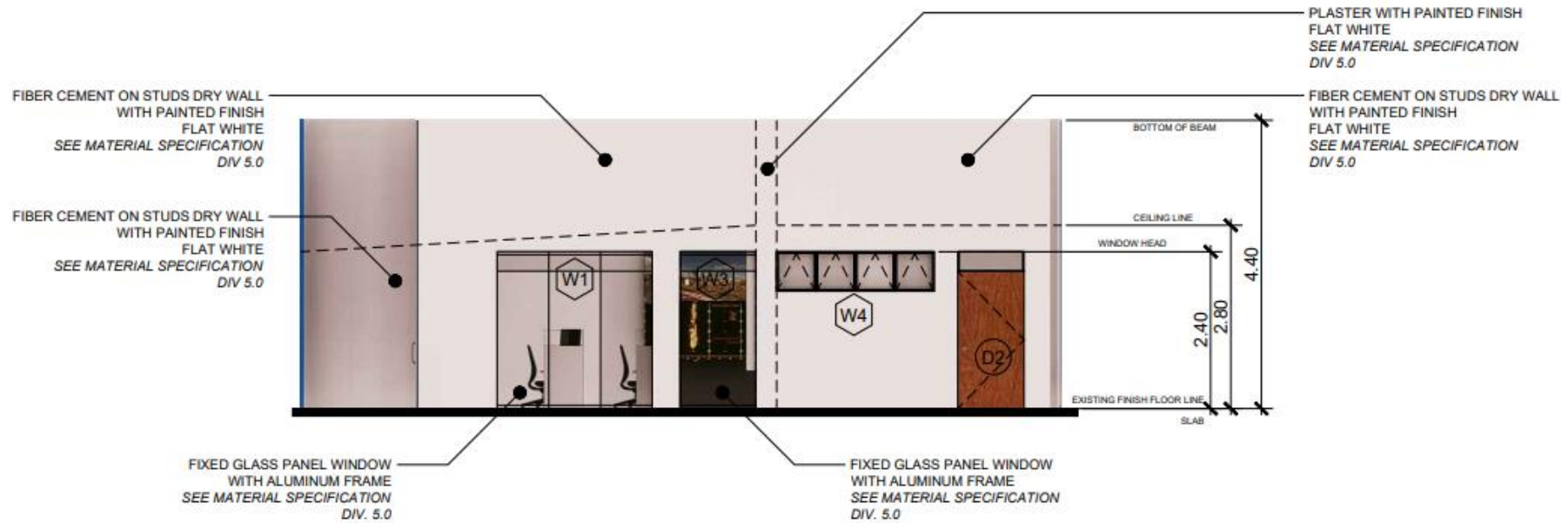

FRONT ELEVATION THRU C-C

SCALE: NOT TO SCALE

NOTE: FURNITURE & EQUIPMENT EXCLUDED

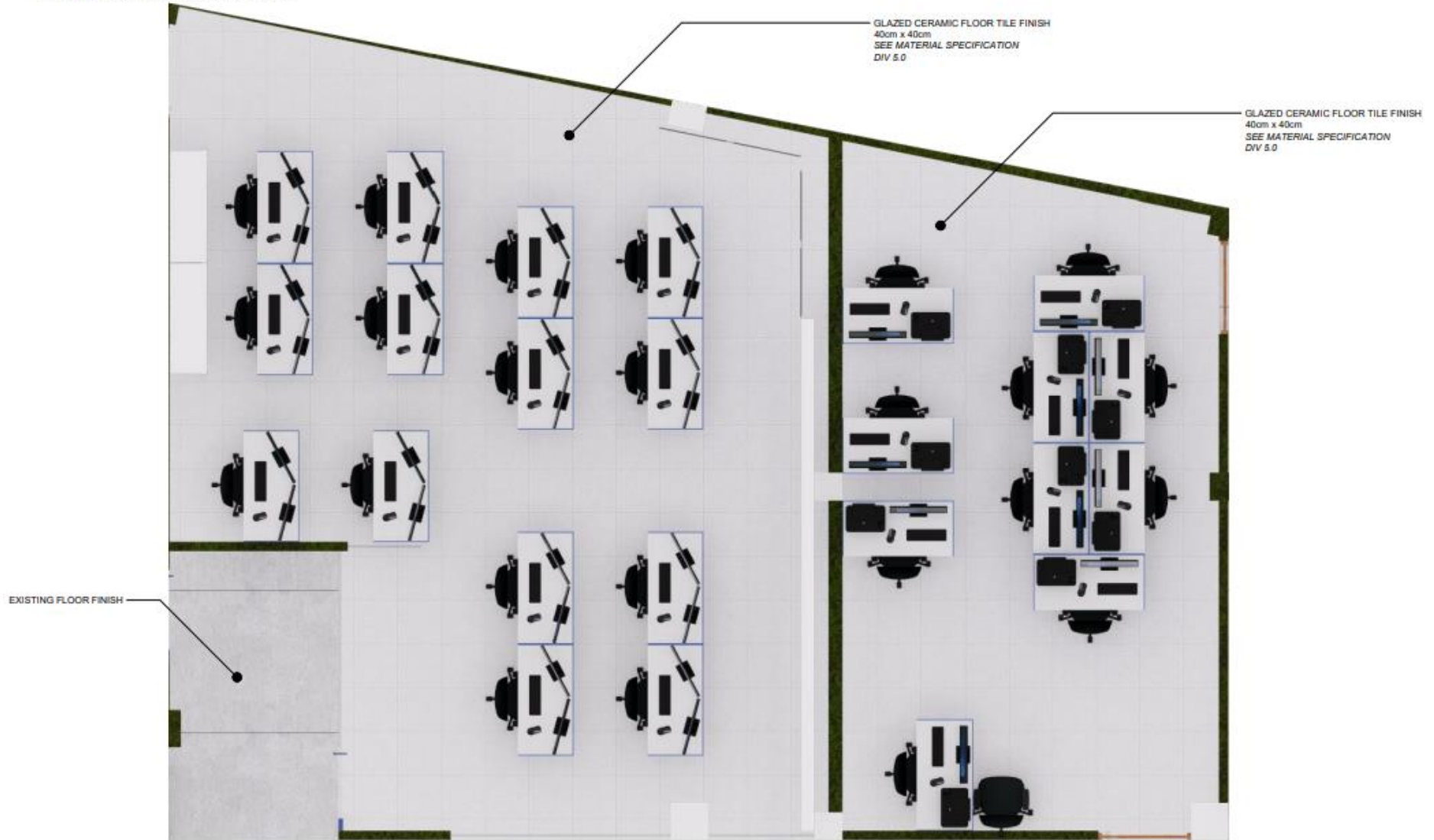

FLOOR FINISH LAYOUT

SCALE: NOT TO SCALE

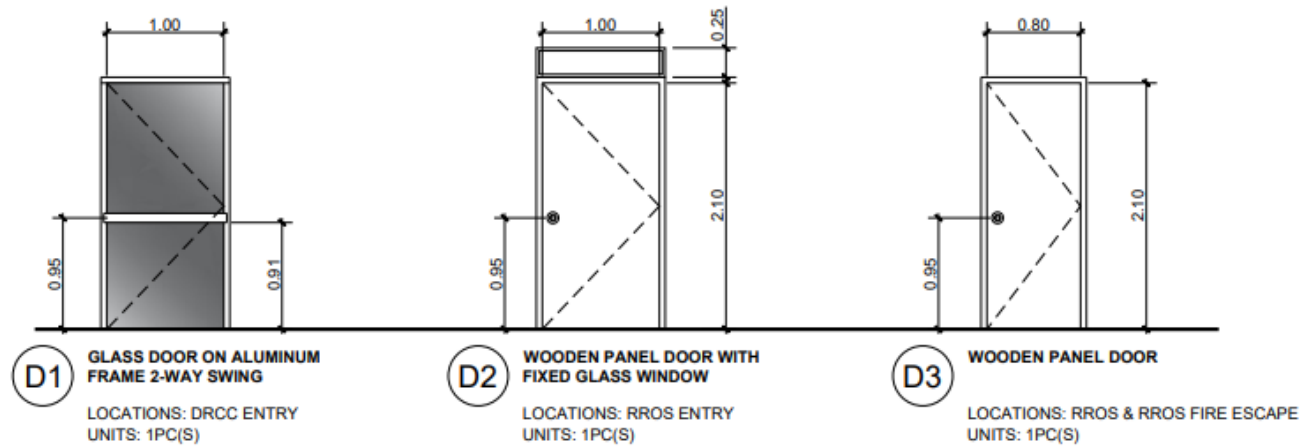
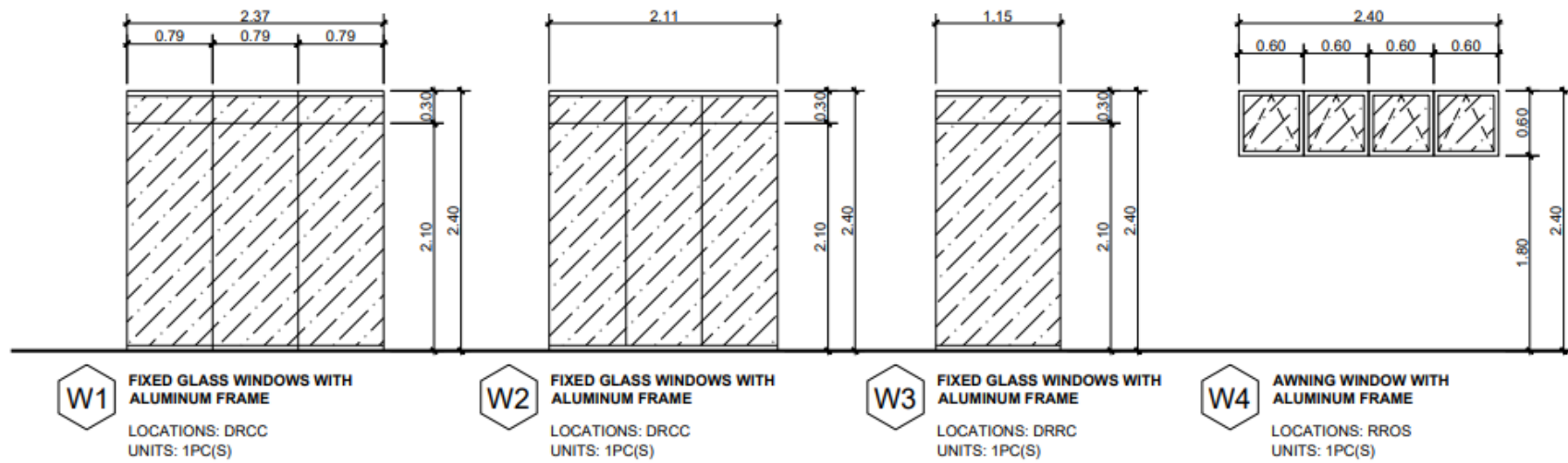

SCHEDULES OF DOORS & WINDOWS

SCALE: F1: NOT TO SCALE

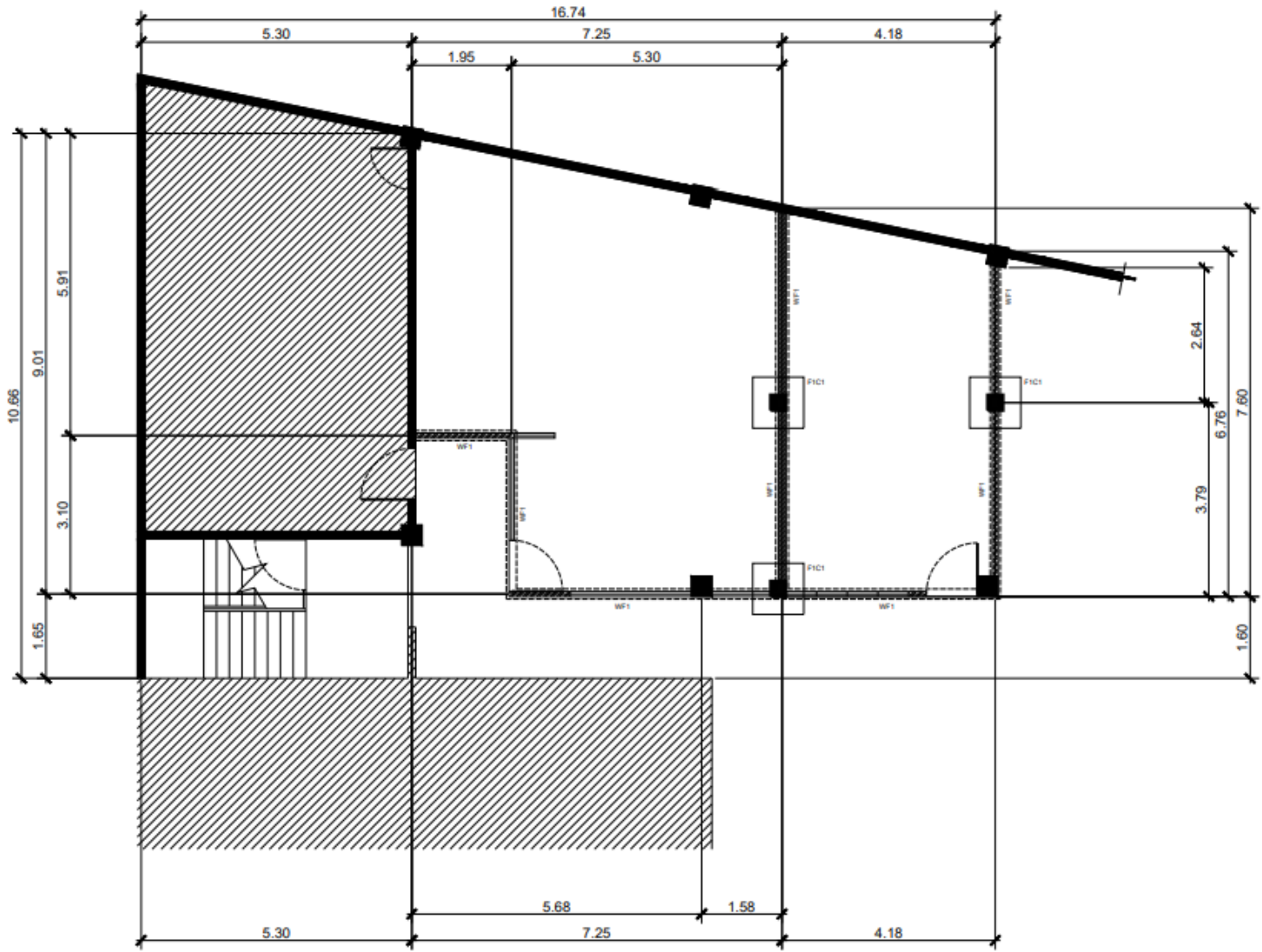

FOUNDATION PLAN

SCALE: NOT TO SCALE

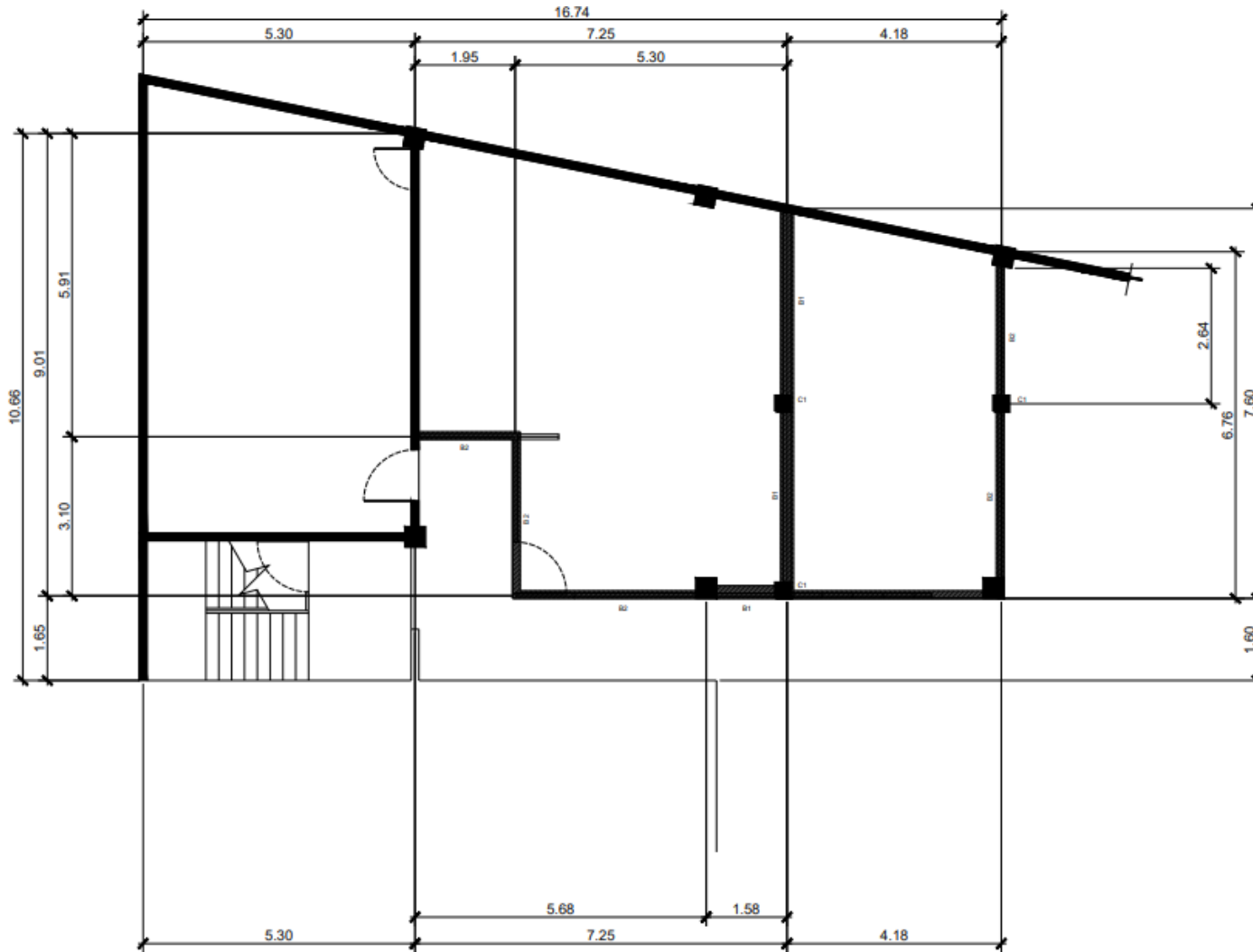

BEAM FRAMING LAYOUT
SCALE/ NOT TO SCALE



C1 PLAN

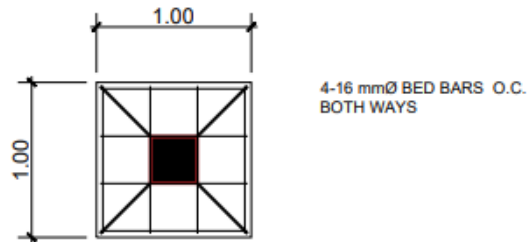

F1C1 PLAN

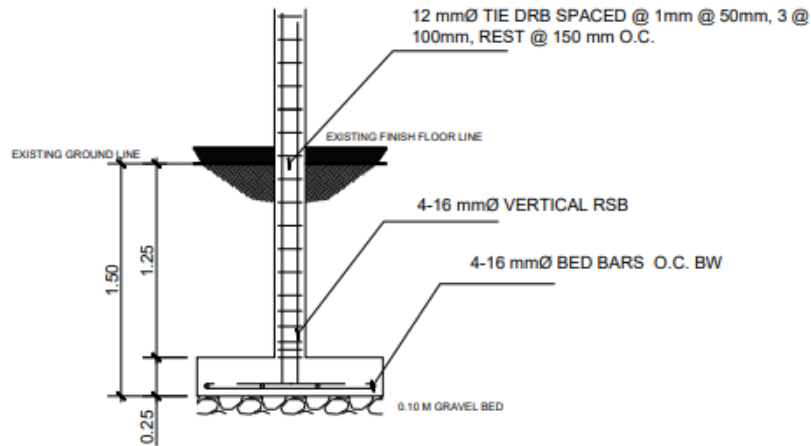

F1C1 SECTION

COLUMN & FOOTING DETAIL

SCALE// NOT TO SCALE

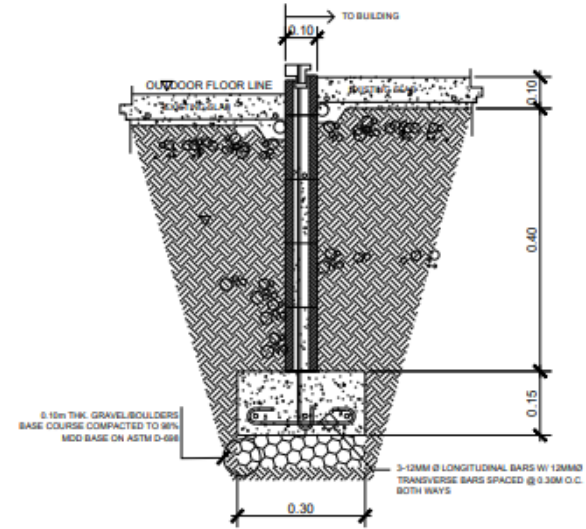

WALL FOOTING DETAIL

SCALE// NOT TO SCALE



BEAM (B1)

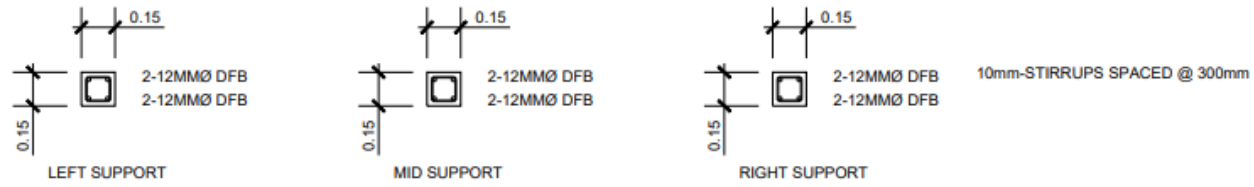

LINTEL BEAM (B2)

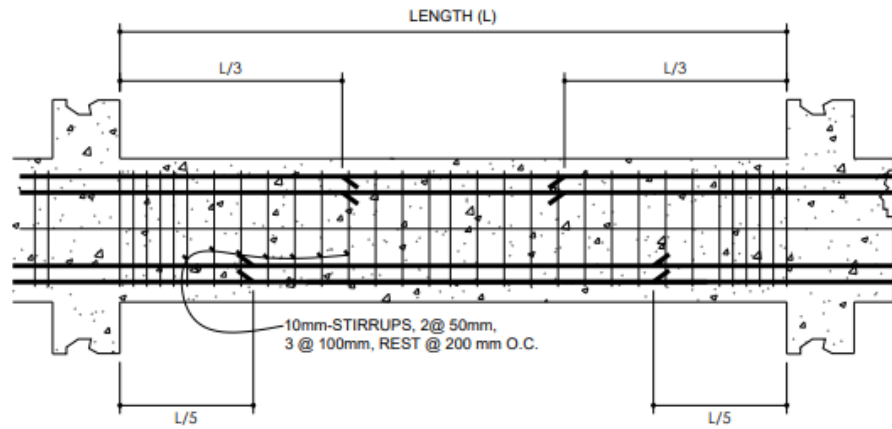







TYPICAL BEAM DETAIL REFERENCE

BEAM DETAIL

SCALE/ NOT TO SCALE





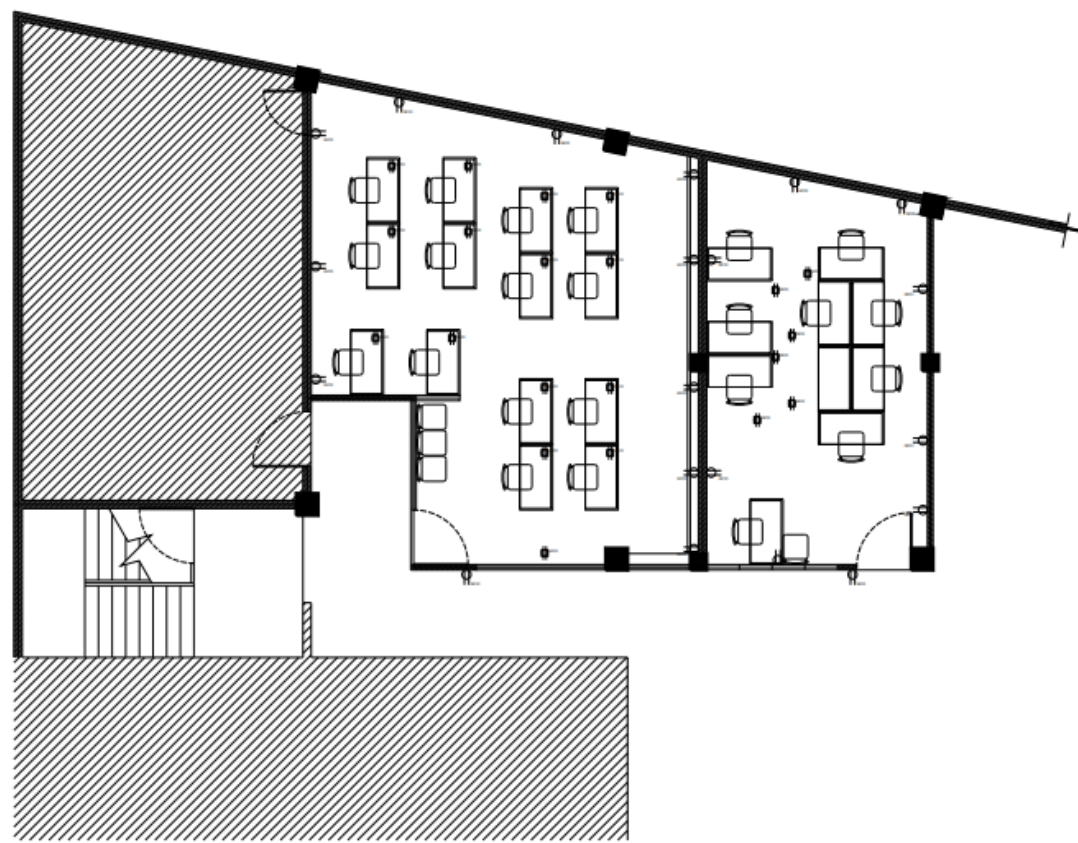















LEGEND

-  CIRCUIT BREAKER
-  CIRCUIT HOMERUN
-  LIGHTING HOMERUN
-  CONVENIENCE OUTLET HOMERUN
-  SINGLE GANG SWITCH
-  DOUBLE GANG SWITCH
-  THREE WAY SWITCH
-  PANEL BOARD
-  WALL LAMP
-  FLOOR MOUNTED LIGHTING
-  RECESSED LIGHTING
-  EMERGENCY LIGHT
-  WATER HEATER OUTLET
-  WATER OUTLET
-  FLOOR MOUNTED CONV. OUTLET (GUARD)
-  CONVENIENCE OUTLET
-  CONVENIENCE OUTLET
-  WATER PROOF FLOOR
-  MECHANICAL UNIT (M.U.)



CONVENIENCE OUTLET LAYOUT
SCALE: NOT TO SCALE





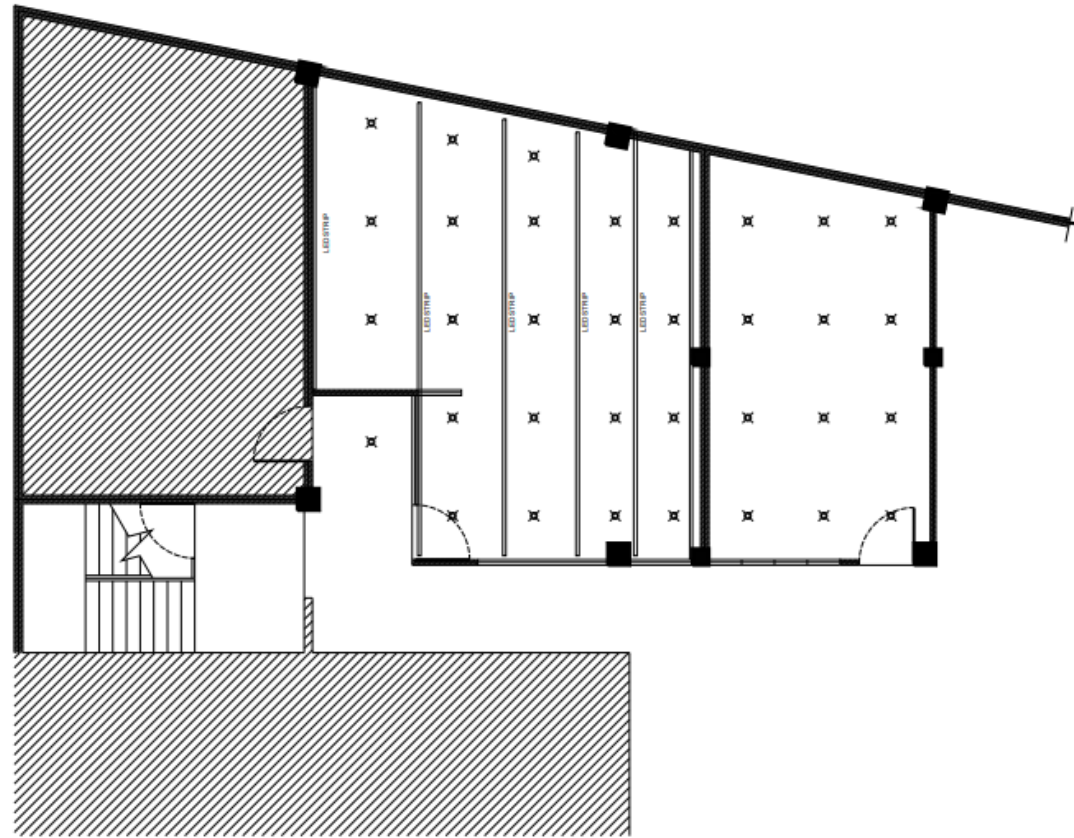















LEGEND

-  CIRCUIT BREAKER
-  CIRCUIT HOMERUN
-  LIGHTING HOMERUN
-  CONVENIENCE OUTLET HOMERUN
-  SINGLE GANG SWITCH
-  DOUBLE GANG SWITCH
-  THREE WAY SWITCH
-  PANEL BOARD
-  WALL LAMP
-  FLOOR MOUNTED LIGHTING
-  RECESSED LIGHTING
-  FLUORESCENT ASSEMBLY
-  EMERGENCY LIGHT
-  WATER HEATER OUTLET
-  SINK OUTLET
-  FLOOR MOUNTED COVER OUTLET (2-GANG)
-  CONVENIENCE OUTLET
-  CONVENIENCE OUTLET
-  WATER PROOF POWER OUTLET
-  AIR CONDITIONED UNIT (HP)



LIGHTING LAYOUT
SCALE: NOT TO SCALE

LEGEND

-  CIRCUIT BREAKER
-  CIRCUIT HOMERUN
-  LIGHTING HOMERUN
-  CONVENIENCE OUTLET HOMERUN
-  SINGLE GANG SWITCH
-  DOUBLE GANG SWITCH
-  THREE WAY SWITCH
-  PANEL BOARD
-  WALL LAMP
-  FLOOR MOUNTED LIGHTING
-  FLUORESCENT OUTLET
-  FLUORESCENT ASSEMBLY
-  EMERGENCY LIGHT
-  WATER/WATER OUTLET
-  RINSE OUTLET
-  FLOOR MOUNTED COMM. OUTLET (2 GANG)
-  CONVENIENCE OUTLET
-  CONVENIENCE OUTLET
-  WATER PROOF POWER
-  FLOOR MOUNTED LIGHTING (LAMP)

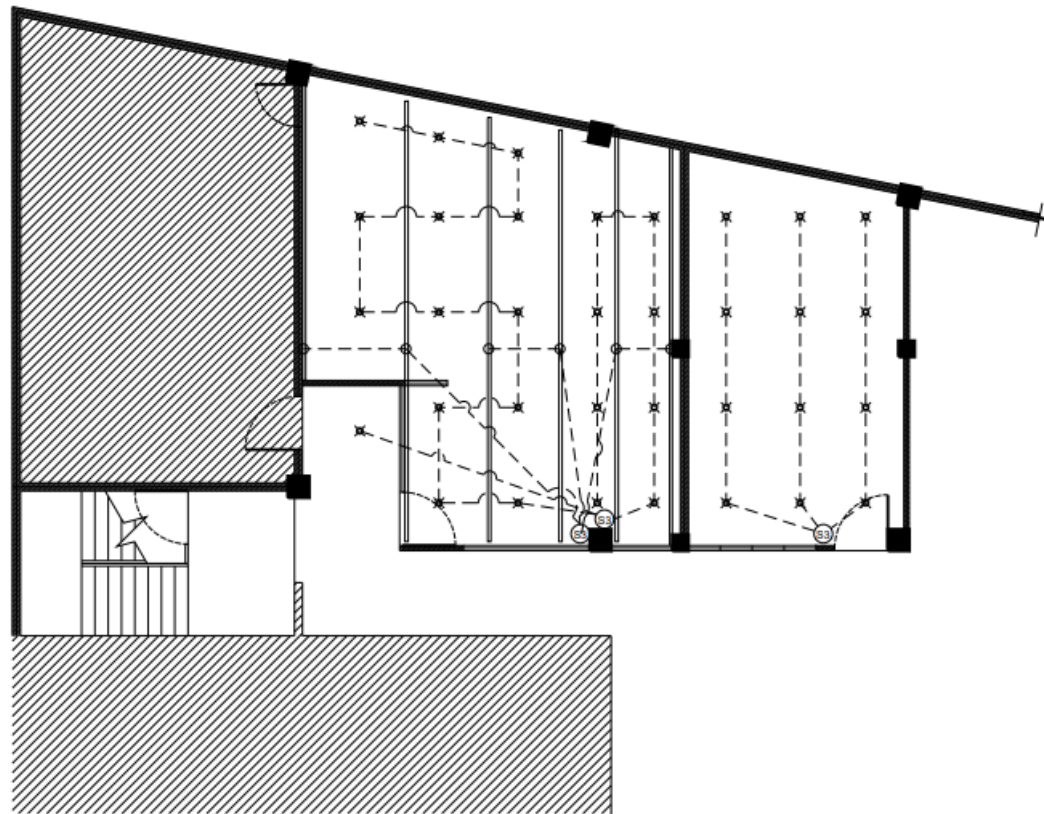

SWITCH LAYOUT LAYOUT

SCALE: NOT TO SCALE



I hereby commit to comply with all the above requirements.

Name of Company/Bidder

Bidder's Signature over Printed Name

Date: _____

Section VIII. Bill of Quantities

Bill of Quantities

Project Title: Remodeling of a Portion of DRMD Warehouse to RROS and DRCC Offices
Location: DSWD Field Office X, Upper Carmen, Cagayan de Oro City
Owner: DSWD Field Office X
Estimated Contract Amount: 1,258,104.50

CONTRACT					
ITEM NO.	ITEM DESCRIPTION	QTY	UNIT	UNIT COST	TOTAL COST
I	Excavation Works	24	cu.m.		
II	Gravel Bedding	15	sq.m.		
III	Reinforcement Bar Installation	681	kg		
IV	Formworks	41	sq.m		
V	Concreting Works	5	cu.m.		
VI	CHB Installation and Plastering	102	sq.m		
VII	Painting Works	371	sq.m		
VIII	Tile Works	99	sq.m		
IX	Ceiling Works	99	sq.m		
X	Doors and Windows	1	lot		
XI	Dry Wall	72	sq.m.		
XII	Demolition Works	1	lot		
				TOTAL	

I hereby certify to comply all of the above requirements.

Name of Company/Bidder

Bidder's Signature over Printed Name

Date: _____

PROGRAM OF WORKS

Name of Project:	Remodeling of a Portion of DRMD Office to RROS and DRCC Offices	
Location:	DSWD FO X, Masterson Ave., Upper Carmen, Cagayan de Oro City	
Category:	Institution	
Physical Target:	98.00 SQ.M	
Total Sub-Project Cost:	Php 1,258,104.50	
Mode of Implementation:	Contract	
Sub-Project Description:	Sub-Project Duration	90 Days
Excavation, Gravel Bedding, Rebar Installation, Formworks and Scaffolding, Concreting Works, Painting, CHB Laying, Window and Door Installation and Electrical and Steel Stair & Ceiling Support and Demolition of Existing Floor Portions.	Equipment Needed	Chipping Gun, Power Drill, Circular Saw, Grinder, Concrete Bagger Mixer, Welding Machine, Concrete Vibrator
	Technical Personnel:	Engineer/Architect, Foreman, Skilled and Unskilled Workers

ITEM NO.	SCOPE OF WORK	WT. %	QTY	UNIT	UNIT COST	TOTAL DIRECT COST
I	Excavation Works		24.00	cu.m.		
II	Gravel Bedding		15.00	sq.m.		
III	Reinforcement Bar Installation		681	kg		
IV	Formworks		41.00	sq.m		
V	Concreting Works		5.00	cu.m.		
VI	CHB Installation and Plastering		102.00	sq.m		
VII	Painting Works		371.00	sq.m		
VIII	Tile Works		99.00	sq.m		

IX	Ceiling Works		99.00	sq.m		
X	Doors and Windows		1	lot		
XI	Dry Wall		72.00	sq.m.		
XII	Demolition Works		1	lot		
XIII	Electrical Works		1	lot		
XIV	Disposal		3.00	cu.m.		
TOTAL		100%				

COST BREAKDOWN

Breakdown Of Cost		Direct Cost	Indirect Cost			
			OCM	Profit	Vat	TOTAL
A	MATERIALS					
B	LABOR					
C	EQUIPMENT					
D	Project Signage and Billboard					
Total Contract Cost						
TOTAL PROJECT COST						

I hereby certify to comply all of the above requirements.

Name of Company/Bidder

Bidder's Signature over Printed Name

Date: _____

Section IX. Checklist of Technical and Financial Documents

Checklist of Technical and Financial Documents

I. TECHNICAL COMPONENT ENVELOPE

Class "A" Documents

Legal Documents

- (a) Valid PhilGEPS Registration Certificate (Platinum Membership) (all pages) in accordance with Section 8.5.2 of the IRR;

Technical Documents

- (b) Statement of the prospective bidder of all its ongoing government and private contracts, including contracts awarded but not yet started, if any, whether similar or not similar in nature and complexity to the contract to be bid; **and**
- (c) Statement of the bidder's Single Largest Completed Contract (SLCC) similar to the contract to be bid, except under conditions provided under the rules; **and**
- (d) Special PCAB License in case of Joint Ventures **and** registration for the type and cost of the contract to be bid; **and**
- (e) Original copy of Bid Security. If in the form of a Surety Bond, submit also a certification issued by the Insurance Commission **or** original copy of Notarized Bid Securing Declaration; **and**
- (f) Project Requirements, which shall include the following:
 - a. Organizational chart for the contract to be bid;
 - b. List of contractor's key personnel (*e.g.*, Project Manager, Project Engineers, Materials Engineers, and Foremen), to be assigned to the contract to be bid, with their complete qualification and experience data;
 - c. Construction Schedule and S-Curve;
 - d. Manpower Schedule;
 - e. Construction Methods;
 - f. Equipment Utilization Schedule;
 - g. PERT/CPM;
 - h. List of contractor's major equipment units, which are owned, leased, and/or under purchase agreements, supported by proof of ownership or certification of availability of equipment from the equipment lessor/vendor for the duration of the project, as the case may be; **and**
- (g) Original duly signed Omnibus Sworn Statement (OSS) **and** if applicable, Original Notarized Secretary's Certificate in case of a corporation, partnership, or cooperative; or Original Special Power of Attorney of all members of the joint venture giving full power and authority to its officer to sign the OSS and do acts to represent the Bidder.

- (h) Certificate of Site Visit

Financial Documents

- (i) The prospective bidder's computation of Net Financial Contracting Capacity (NFCC).

Class "B" Documents

- (j) If applicable, duly signed joint venture agreement (JVA) in accordance with RA No. 4566 and its IRR in case the joint venture is already in existence **or** duly notarized statements from all the potential joint venture partners stating that they will enter into and abide by the provisions of the JVA in the instance that the bid is successful.

II. FINANCIAL COMPONENT ENVELOPE

- (k) Original of duly signed and accomplished Financial Bid Form; **and**
Other documentary requirements under RA No. 9184

- (l) Original of duly signed Bid Prices in the Bill of Quantities; **and**
- (m) Duly accomplished Detailed Estimates Form, including a summary sheet indicating the unit prices of construction materials, labor rates, and equipment rentals used in coming up with the Bid; **and**
- (n) Cash Flow by Quarter.

Section X. Bidding Forms

Bid Form for the Procurement of Infrastructure Projects

[shall be submitted with the Bid]

BID FORM

Date: _____

Project Identification No. : _____

To: *[name and address of Procuring Entity]*

Having examined the Philippine Bidding Documents (PBDs) including the Supplemental or Bid Bulletin Numbers *[insert numbers]*, the receipt of which is hereby duly acknowledged, we, the undersigned, declare that:

- a. We have no reservation to the PBDs, including the Supplemental or Bid Bulletins, for the Procurement Project: *[insert name of contract]*;
- b. We offer to execute the Works for this Contract in accordance with the PBDs;
- c. The total price of our Bid in words and figures, excluding any discounts offered below is: *[insert information]*;
- d. The discounts offered and the methodology for their application are: *[insert information]*;
- e. The total bid price includes the cost of all taxes, such as, but not limited to: *[specify the applicable taxes, e.g. (i) value added tax (VAT), (ii) income tax, (iii) local taxes, and (iv) other fiscal levies and duties]*, which are itemized herein and reflected in the detailed estimates,
- f. Our Bid shall be valid within the period stated in the PBDs, and it shall remain binding upon us at any time before the expiration of that period;
- g. If our Bid is accepted, we commit to obtain a Performance Security in the amount of *[insert percentage amount]* percent of the Contract Price for the due performance of the Contract, or a Performance Securing Declaration in lieu of the the allowable forms of Performance Security, subject to the terms and conditions of issued GPPB guidelines¹ for this purpose;
- h. We are not participating, as Bidders, in more than one Bid in this bidding process, other than alternative offers in accordance with the Bidding Documents;
- i. We understand that this Bid, together with your written acceptance thereof included in your notification of award, shall constitute a binding contract between us, until a formal Contract is prepared and executed; and
- j. We understand that you are not bound to accept the Lowest Calculated Bid or any

¹ currently based on GPPB Resolution No. 09-2020

other Bid that you may receive.

- k. We likewise certify/confirm that the undersigned, is the duly authorized representative of the bidder, and granted full power and authority to do, execute and perform any and all acts necessary to participate, submit the bid, and to sign and execute the ensuing contract for the [Name of Project] of the [Name of the Procuring Entity].

- l. We acknowledge that failure to sign each and every page of this Bid Form, including the Bill of Quantities, shall be a ground for the rejection of our bid.

Name: _____

Legal Capacity: _____

Signature: _____

Duly authorized to sign the Bid for and behalf of: _____

Date: _____

Statement of All On-Going Government and Private Contracts, Including Contracts Awarded but Not Yet Started, Whether Similar or Not Similar in Nature and Complexity to the Contract to be Bid

Business Name: _____

Business Address: _____

A. Government

Nature of Contract (Project Title)	a. Owner's Name	Project Cost	Bidder's Role		a. Date Awarded	% of Accomplishment		Value of Outstanding Works (Undelivered Portion)
	b. Address		Description	%	b. Date Started	Planned	Actual	
	c. Contact Nos.				c. Target Date of Completion			
1	a.				a.			
	b.				b.			
	c.				c.			
2	a.				a.			
	b.				b.			
	c.				c.			

B. Private

Nature of Contract (Project Title)	a. Owner's Name	Project Cost	Bidder's Role		a. Date Awarded	% of Accomplishment		Value of Outstanding Works (Undelivered Portion)
	b. Address		Description	%	b. Date Started	Planned	Actual	
	c. Contact Nos.				c. Target Date of Completion			
1	a.				a.			
	b.				b.			
	c.				c.			
2	a.				a.			
	b.				b.			
	c.				c.			

Note: The following documents must be available upon request of the Bids and Award Committee (BAC) or designated Technical Working Group (TWG) during Post-Qualification to support this statement: (a) Contract or Purchase Order, (b) Official Receipt(s) or Sales Invoice or (c) User's Certificate of Acceptance/Completion

Name: _____

Legal Capacity: _____

Signature: _____

Duly authorized to sign the Bid for and behalf of: _____

Date: _____

Statement of Single Largest Completed Contract (SLCC) ² Similar to the Contract to be Bid

Business Name: _____

Business Address: _____

Nature of Contract (Project Title)	a. Owner's Name	Project Cost	Bidder's Role		a. Date Awarded
	b. Address		Description	%	b. Date Started
	c. Contact Nos.				c. Date Completed
	a.				a.
	b.				b.
	c.				c.

Note: *The following documents must be attached to support this statement: (a) Official Receipt(s) or Sales Invoice or (b) User's Certificate of Acceptance/Completion*

Name: _____

Legal Capacity: _____

Signature: _____

Duly authorized to sign the Bid for and behalf of: _____

Date: _____

² *The Bidder must have completed, within the period specified in the Invitation to Bid and ITB Clause 5.3 of Section III. Bid Data Sheet, a single contract that is similar to the project to be bid, equivalent to a percentage (%) of the ABC specified in ITB Clause 5.3(a) of Section II. Instruction to Bidders.*

Bid Securing Declaration Form

[shall be submitted with the Bid if bidder opts to provide this form of bid security]

REPUBLIC OF THE PHILIPPINES)
CITY OF _____) S.S.

BID SECURING DECLARATION **Project Identification No.: *[Insert number]***

To: *[Insert name and address of the Procuring Entity]*

I/We, the undersigned, declare that:

1. I/We understand that, according to your conditions, bids must be supported by a Bid Security, which may be in the form of a Bid Securing Declaration.
2. I/We accept that: (a) I/we will be automatically disqualified from bidding for any procurement contract with any procuring entity for a period of two (2) years upon receipt of your Blacklisting Order; and, (b) I/we will pay the applicable fine provided under Section 6 of the Guidelines on the Use of Bid Securing Declaration, within fifteen (15) days from receipt of the written demand by the procuring entity for the commission of acts resulting to the enforcement of the bid securing declaration under Sections 23.1(b), 34.2, 40.1 and 69.1, except 69.1(f), of the IRR of RA No. 9184; without prejudice to other legal action the government may undertake.
3. I/We understand that this Bid Securing Declaration shall cease to be valid on the following circumstances:
 - a. Upon expiration of the bid validity period, or any extension thereof pursuant to your request;
 - b. I am/we are declared ineligible or post-disqualified upon receipt of your notice to such effect, and (i) I/we failed to timely file a request for reconsideration or (ii) I/we filed a waiver to avail of said right; and
 - c. I am/we are declared the bidder with the Lowest Calculated Responsive Bid, and I/we have furnished the performance security and signed the Contract.

IN WITNESS WHEREOF, I/We have hereunto set my/our hand/s this ____ day of *[month]* *[year]* at *[place of execution]*.

*[Insert NAME OF BIDDER OR ITS AUTHORIZED
REPRESENTATIVE]
[Insert signatory's legal capacity]
Affiant*

[Jurat]

[Format shall be based on the latest Rules on Notarial Practice]

Omnibus Sworn Statement (Revised)

[shall be submitted with the Bid]

REPUBLIC OF THE PHILIPPINES)
CITY/MUNICIPALITY OF _____) S.S.

AFFIDAVIT

I, [Name of Affiant], of legal age, [Civil Status], [Nationality], and residing at [Address of Affiant], after having been duly sworn in accordance with law, do hereby depose and state that:

1. *[Select one, delete the other:]*

[If a sole proprietorship:] I am the sole proprietor or authorized representative of [Name of Bidder] with office address at [address of Bidder];

[If a partnership, corporation, cooperative, or joint venture:] I am the duly authorized and designated representative of [Name of Bidder] with office address at [address of Bidder];

2. *[Select one, delete the other:]*

[If a sole proprietorship:] As the owner and sole proprietor, or authorized representative of [Name of Bidder], I have full power and authority to do, execute and perform any and all acts necessary to participate, submit the bid, and to sign and execute the ensuing contract for [Name of the Project] of the [Name of the Procuring Entity], as shown in the attached duly notarized Special Power of Attorney;

[If a partnership, corporation, cooperative, or joint venture:] I am granted full power and authority to do, execute and perform any and all acts necessary to participate, submit the bid, and to sign and execute the ensuing contract for [Name of the Project] of the [Name of the Procuring Entity], as shown in the attached [state title of attached document showing proof of authorization (e.g., duly notarized Secretary's Certificate, Board/Partnership Resolution, or Special Power of Attorney, whichever is applicable)];

3. [Name of Bidder] is not "blacklisted" or barred from bidding by the Government of the Philippines or any of its agencies, offices, corporations, or Local Government Units, foreign government/foreign or international financing institution whose blacklisting rules have been recognized by the Government Procurement Policy Board, **by itself or by relation, membership, association, affiliation, or controlling interest with another blacklisted person or entity as defined and provided for in the Uniform Guidelines on Blacklisting;**

4. Each of the documents submitted in satisfaction of the bidding requirements is an authentic copy of the original, complete, and all statements and information provided therein are true and correct;

5. [Name of Bidder] is authorizing the Head of the Procuring Entity or its duly authorized representative(s) to verify all the documents submitted;

6. *[Select one, delete the rest:]*

[If a sole proprietorship:] The owner or sole proprietor is not related to the Head of the Procuring Entity, Procurement Agent if engaged, members of the Bids and Awards

Committee (BAC), the Technical Working Group, and the BAC Secretariat, the head of the Project Management Office or the end-user unit, and the project consultants by consanguinity or affinity up to the third civil degree;

[If a partnership or cooperative:] None of the officers and members of *[Name of Bidder]* is related to the Head of the Procuring Entity, Procurement Agent if engaged, members of the Bids and Awards Committee (BAC), the Technical Working Group, and the BAC Secretariat, the head of the Project Management Office or the end-user unit, and the project consultants by consanguinity or affinity up to the third civil degree;

[If a corporation or joint venture:] None of the officers, directors, and controlling stockholders of *[Name of Bidder]* is related to the Head of the Procuring Entity, Procurement Agent if engaged, members of the Bids and Awards Committee (BAC), the Technical Working Group, and the BAC Secretariat, the head of the Project Management Office or the end-user unit, and the project consultants by consanguinity or affinity up to the third civil degree;

7. *[Name of Bidder]* complies with existing labor laws and standards; and
8. *[Name of Bidder]* is aware of and has undertaken the responsibilities as a Bidder in compliance with the Philippine Bidding Documents, which includes:
 - a. Carefully examining all of the Bidding Documents;
 - b. Acknowledging all conditions, local or otherwise, affecting the implementation of the Contract;
 - c. Making an estimate of the facilities available and needed for the contract to be bid, if any; and
 - d. Inquiring or securing Supplemental/Bid Bulletin(s) issued for the *[Name of the Project]*.
9. *[Name of Bidder]* did not give or pay directly or indirectly, any commission, amount, fee, or any form of consideration, pecuniary or otherwise, to any person or official, personnel or representative of the government in relation to any procurement project or activity.
10. **In case advance payment was made or given, failure to perform or deliver any of the obligations and undertakings in the contract shall be sufficient grounds to constitute criminal liability for Swindling (Estafa) or the commission of fraud with unfaithfulness or abuse of confidence through misappropriating or converting any payment received by a person or entity under an obligation involving the duty to deliver certain goods or services, to the prejudice of the public and the government of the Philippines pursuant to Article 315 of Act No. 3815 s. 1930, as amended, or the Revised Penal Code.**

IN WITNESS WHEREOF, I have hereunto set my hand this ___ day of ___, 20__ at _____, Philippines.

[Insert NAME OF BIDDER OR ITS AUTHORIZED REPRESENTATIVE]

[Insert signatory's legal capacity]
Affiant

[Jurat]

[Format shall be based on the latest Rules on Notarial Practice]

